

WARNING: FAILURE TO FOLLOW THESE INSTRUCTIONS AND WARNINGS MAY RESULT IN DEATH, SERIOUS INJURY OR SIGNIFICANT PROPERTY DAMAGE. For your protection, read and follow these warnings and instructions carefully before installing or maintaining this equipment. These instructions do not attempt to cover all installation and maintenance situations. If you do not understand these instructions or additional information is required, contact your local distributor.

WARNING: RISK OF ELECTRIC SHOCK - NEVER CONNECT TO, DISCONNECT FROM, OR SERVICE WHILE EQUIPMENT IS ENERGIZED.

WARNING: RISK OF FIRE. Lamps are hot. Keep combustible material away from hot parts. Observe lamp manufacturer's warnings, recommendations and restrictions on lamp operation and maintenance. Make sure lamps are correctly installed.

CAUTION: The battery in this unit may not be fully charged. After powering the unit, charge the battery for at least 24 hours, then normal operation of this unit should take effect. To check, press the TEST button. The lamps on the unit should turn on. (Refer to OPERATION BATTERY BACK UP on page 3 for more testing information)

IMPORTANT SAFEGUARDS: When using electrical equipment, basic safety precautions should always be followed, including the following:

- Do not use outdoors. Suitable for use in 50°F to 104°F (10°C to 40°C) indoor damp locations.
- Consult local building code for approved wiring and installation.
- Disconnect AC power before servicing and installation.
- Do not mount near gas or electric heaters.
- Do not use this equipment for anything other than its intended use.
- The use of accessory equipment not recommended by the manufacturer will void product listing and warranty and may cause an unsafe condition.
- Any service on this equipment should be performed by qualified personnel only.
- Equipment should be mounted in locations and at heights where it will not be subject to tampering by unauthorized personnel.
- Use caution when servicing batteries.
- Cap unused wires with enclosed wire nuts or other approved method.
- Make sure wire terminations are secure and leads are properly tucked in appropriate wire channels.

NOTE: Max mounting height is 10 ft to achieve at least 1ft candle of illuminance in emergency mode.

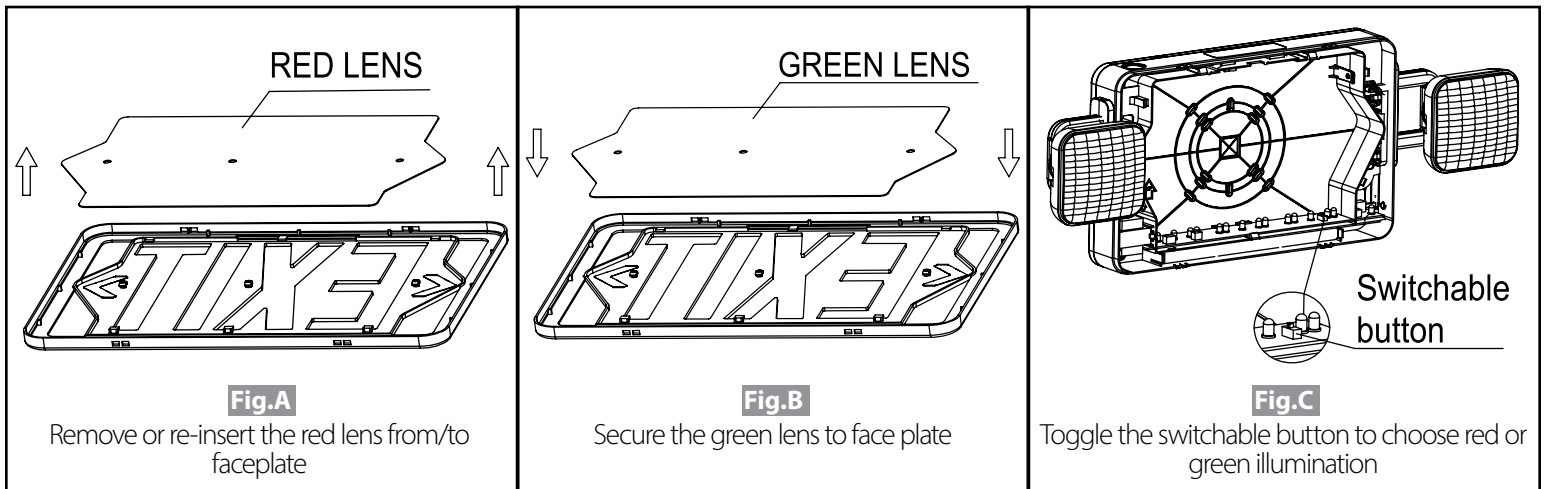
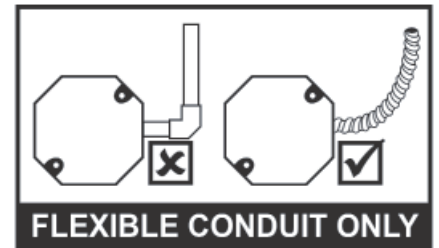
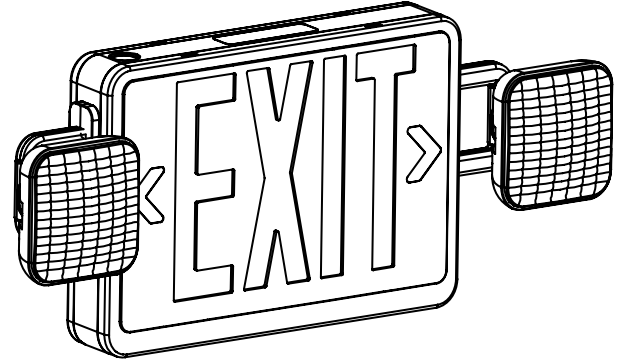

NOTE: EXIT ships standard RED. Refer to Toggle Switch section for GREEN LED configuration.

INSTALLATION INSTRUCTIONS (back mount):

1. Remove EXIT stencil faceplate from housing. Remove RED lens from faceplate (see Fig. A). Set aside.
2. Drill or knock out appropriate knockouts on back plate to fit junction box mounting points.
3. Drill or knock out center hole in back plate for EXIT supply wire leads.
4. Route EXIT supply wires through center hole of the back plate and make wiring connection. For 120V, use black and white wires and for 277V, use red and white wires. **WARNING:** Properly insulate the unused lead with a wire nut (provided) or other approved means.
5. Secure back plate to junction box (hardware not included)
6. Remove knockout chevron(s) on faceplate, re-insert RED lens to faceplate (see Fig. A)(or GREEN if applicable, see Fig. B). Secure EXIT stencil faceplate back onto housing.
7. Toggle the switchable to select GREEN if applicable (see Fig. C).
8. Connect battery only after continuous AC power can be provided to the unit.
9. Apply continuous AC power and press "TEST" button to check operation. (See operation battery back-up for testing procedures)

INSTALLATION INSTRUCTIONS (top mount):

1. Remove EXIT stencil faceplate from housing. Remove RED lens from faceplate (see Fig. A). Set aside.
2. Place screws (provided) in holes on the canopy.
3. Remove the mounting hole plug located on the top of the housing.
4. Route EXIT supply wires through mounting hole in top of the housing. Route EXIT supply wires through mounting canopy. Dress wires carefully through housing.
5. Route wires from junction box through metal mounting plate. Secure mounting plate to junction box (*hardware not included*).
6. Make wiring connection. For 120V, use black and white wires and for 277V, use red and white wires
WARNING: Properly insulate the unused lead with a wire nut (provided) or other approved means.
7. Push wire connections through middle metal plate and into the J-Box.
8. Secure the canopy to the steel mounting plate with screws installed in step 2.
9. Remove proper chevron(s) on faceplate, re-insert RED lens to faceplate, see Fig. A. (*or GREEN if applicable, see Fig. B*). Secure EXIT stencil faceplate back onto housing.
10. Toggle the switchable to select GREEN if applicable (*see Fig. C*).
11. Connect battery only after continuous AC power can be provided to the unit.
12. Apply continuous AC power and press "TEST" button to check operation. (*See operation battery back-up for testing procedures*)

INSTALLATION INSTRUCTIONS (side mount):

1. Remove EXIT stencil faceplate from housing. Remove RED lens from faceplate (see Fig. A). Set aside.
2. Place screws (provided) in holes on the canopy.
3. Remove the lamp head from the housing on the desired mounting position. Disconnect the lamp head wires from the lamp PC board. Set lamp head aside.
4. Route EXIT supply wire through mounting hole in side of the housing where the lamp head was removed. Route EXIT supply wire through mounting canopy. Dress wires carefully through housing.
5. Route wires from junction box through metal mounting plate. Secure mounting plate to junction box (*hardware not included*).
6. Make wiring connection. For 120V, use black and white wires and for 277V, use red and white wires.
WARNING: Properly insulate the unused lead with a wire nut (provided) or other approved means.
7. Push wire connections through middle metal plate and into the J-Box.
8. Secure the canopy to the steel mounting plate with screws installed in step 2.
9. Remove proper chevron(s) on faceplate, re-insert RED lens to faceplate, see Fig. A. (*or GREEN if applicable, see Fig. B*). Secure EXIT stencil faceplate back onto housing.
10. Toggle the switchable to select GREEN if applicable (*see Fig. C*).
11. Connect battery only after continuous AC power can be provided to the unit.
12. Apply continuous AC power and press "TEST" button to check operation. (*See operation battery back-up for testing procedures*).

INSTALLATION (relocation of lamp head to top of housing):

1. Remove the mounting hole plug located on the top of the housing.
2. Snap lamp head that was removed from the side of the housing into the mounting hole plug located on the top of the housing.
3. Route lamp head wires through housing channels and make connection on the lamp pc board.

OPERATION (battery backup):

1. Apply AC power to the unit. Connect the battery to the PCBA, the LED indicator will be RED.
2. After the battery has been left to charge for 24 hours, test the unit by pushing the switch. The LED indicator turns OFF and the LED board stays ON.
3. When the switch is released, the LED indicator turns back to RED and LED board stays ON.

MAINTENANCE:

CAUTION: Always turn off AC power to the equipment before servicing. Servicing should be performed by a qualified service technician. Use only MANUFACTURER supplied replacements parts.

BATTERY: The battery supplied with the ECL1v2 model requires no maintenance. However, it should be tested periodically and replaced when it no longer operates the connected sign for the duration of a 30-second or 90-minute test. The battery supplied in this sign has a typical life of 5 years when used in a normal ambient temperature of 72° F.

LED STATUS INDICATOR KEY and TROUBLESHOOTING

Visual Status	Indication	Troubleshooting/Actions to Take
UNLIT	<ol style="list-style-type: none"> 1. Battery connection is not made. 2. Battery has been diagnosed as dead or defective after 24 hours of continuous charging with AC power supplied. 3. AC power has not been supplied. 	<ol style="list-style-type: none"> 1. Make connection; or if battery is connected, disconnect battery for eight seconds and then reconnect. 2. Replace the battery. 3. Supply AC power.
RED	Battery is connected, AC power has been supplied and fixture is in charging state.	This is the normal state. No action required.

WIRING DIAGRAM:

NON-REMOTE MODELS (ECL120UNVWHS2)

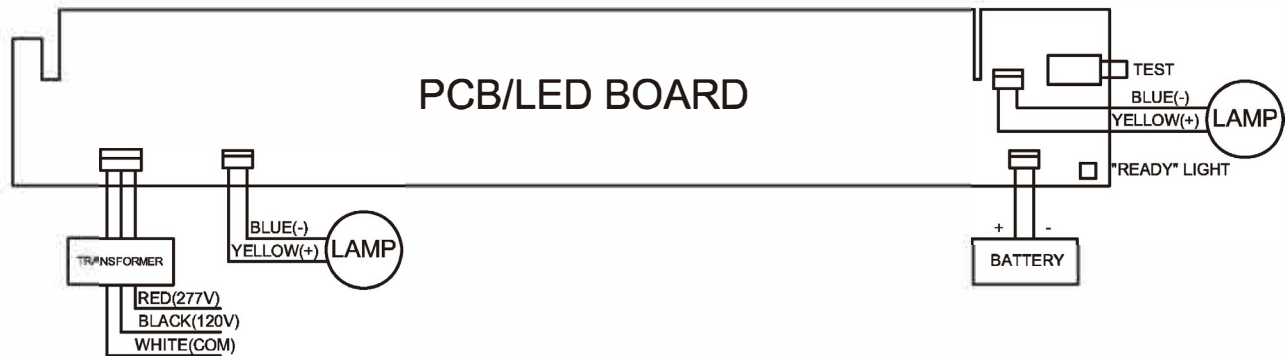

REMOTE CAPABLE MODELS (ECL120UNVWHS2R)

