

LSC Select

Selectable CCT & Output LED Linear Strip

Product Description

The LSC Select LED Linear Strip adds on to our tried-and-true linear strip with selectable CCT and light output options, delivering optimal performance and long life in a slim design that's ideal for general ambient lighting in retail, warehouse, residential utility, and light commercial or industrial applications. This versatile fixture is easy to surface mount on both ceilings and walls and can accommodate end-to-end runs. The LSC features a semi-circular, milky-white lens that offers a more polished aesthetic while eliminating hotspots, and is an economical, energy-efficient lighting alternative to single lamp fluorescent strips and some wraparound fixtures. For even greater energy savings, an optional microwave occupancy sensor is also available.

Construction

- Durable 20 gauge steel construction
- Smooth formed sides for safe handling
- Similar form factor to single lamp fluorescent strip

Optical System

- Semi-circular, milky-white diffuser eliminates hotspots and pixelation
- Lens retention method securely holds diffuser in ceiling or wall mount

Electrical

- Input voltage of 120-277VAC
- CCT selectable at 3500K, 4000K, or 5000K
- Lumen output selectable on 4' model only;
- Full-range dimming from 1 - 10VDC
- Power factor > 0.9
- THD < 20%
- Through wiring capable for end to end runs
- Operating temperature rating of 0°F to 120°F (-18°C to 49°C)

Controls

- Optional occupancy sensor kit available
- NLC (Network Lighting Controls) option available
- Bluetooth Low Energy (BLE) mesh network providing Luminaire Level Lighting Control
- Luminaire integrated 12V socket (optional) allows for field installed BLE PIR/Daylight sensor with adjustable arm (N2) (shipped with luminaire).
- Configurable with the NICOR NLC app available on iOS and Android devices
- Provides full dimming control with occupancy and daylight harvesting functions

Mounting and installation

- Easy surface mount installation on ceilings or walls
- Safety strap-retained LED array allows single person installation
- Multiple knockouts provided for wiring from back or ends
- Features provided for surface, cable, hook and chain, or pendant mount
- Cover plates provided for 4/O box surface installation
- External switches allow for easy CCT and wattage selection
- For installations where power surge may be possible, NICOR recommends installing additional surge protection at the fixture or electrical distribution panel

Listings

- TM-21 Reported L70(9k) life >54,000 hours
- LM-79, LM-80 testing performed in accordance with IESNA standards

Warranty

- 5-year limited system warranty standard
- Warranty does not cover product failure due to an overvoltage event (power surge)

Project

Catalog

Type

Date



Optional Motion Sensor



Ordering

Ordering Information					Example: LSCS14U
Series	Version	Size	Voltage	Controls	Emergency
LSCS	1	2 (2 Foot) ¹	U (120-277V)	(Blank)	(Blank)
		4 (4 Foot)		M (Sensor)	EM8
		8 (8 Foot)		N2 (NLC Controls)	EM16

1. 2 foot size is not available with any emergency option.
 Specifications and dimensions subject to change without notice.

Accessories	Accessories sold separately
Continuous Run Bracket	LSC-10-CR-BRACKET
Pendant Mount Kit	LSCS1PENDANTKIT

NLC Controls
 See www.nicorlighting/network-lighting-controls for more information and NLC Component Data Sheets

Performance Data

Performance Data					
Model Number	Nominal CCT	Nominal Wattage	Light Output (Lm)	Power Draw (W)	Efficacy (Lm/W)
LSCS12U	3500K	20W	2528	19.0	133.1
	4000K	20W	2676	18.5	144.8
	5000K	20W	2562	19.0	134.6
LSCS14U	3500K	22W	3302	22.7	145.5
	4000K	22W	3758	23.3	161.3
	5000K	22W	3366	23.8	141.4
	3500K	28W	4141	29.4	140.8
	4000K	28W	4714	30.2	156.0
	5000K	28W	4221	29.6	142.7
LSCS18U	3500K	40W	5131	38.7	132.7
	4000K	40W	5841	39.7	147.1
	5000K	40W	5231	38.9	134.6
	3500K	65W	8082	59.7	135.4
LSCS18U	4000K	65W	9200	61.3	150.1
	5000K	65W	8239	60.0	137.3

Recommended Dimmers*
Lutron NTSTV-DV-WH
Lutron DVSTV
Cooper SF10P
Legrand RH4FBL3PW

*Not a complete list. Check compatibility before installation.

Photometric Data

LSCS 2' 3500K

Input Voltage (VAC)	120-277
System Level Power (W)	19
Delivered Lumens (Lm)	2528
System Efficacy (Lm/W)	133.1
Correlated Color Temp (K)	3399
Color Rendering Index (CRI)	81
Beam Angle (0)	132.3
Beam Angle (90)	100.2
Spacing Criteria (0)	1.2
Spacing Criteria (90)	1.4

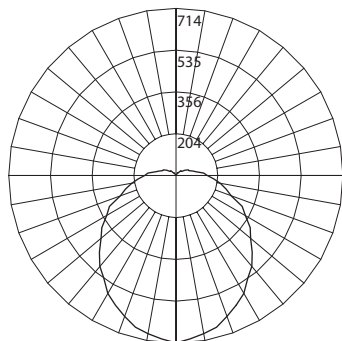

Intensity Summary (Candela Power)	
Angle	Mean CP
0	712
10	697
20	650
30	576
40	483
50	381
60	281
70	189
80	112
90	62

CCT Data Multiplier	
3500K	1.000
4000K	1.044
5000K	1.013

Cone of Light Tabulation		
Mounted height (Feet)	Footcandles Beam Center	Diameter (Feet)
8	11.1	9.4
10	7.2	11.7
12	5.0	14.0
16	2.8	19.0

Zonal Lumen Summary		
Zone	Lumens	% of Luminaire
0-30	548	21.7%
0-40	894	35.4%
0-60	1587	62.8%
0-90	2228	88.1%
90-180	300	11.9%
0-180	2528	100%

Fixture tested per LM-79-08. Photometric data is of the performance of a representative fixture. Results may vary in the field.

Photometric Data

LSCS 4' 3500K

Input Voltage (VAC)	120-277
System Level Power (W)	38.67
Delivered Lumens (Lm)	5131
System Efficacy (Lm/W)	132.7
Correlated Color Temp (K)	3407
Color Rendering Index (CRI)	81
Beam Angle (0)	135.4
Beam Angle (90)	101.4
Spacing Criteria (0)	1.2
Spacing Criteria (90)	1.3

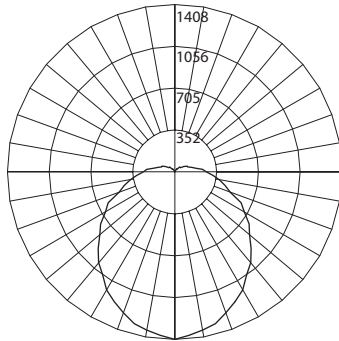

Intensity Summary (Candela Power)

Angle	Mean CP
0	1407
10	1370
20	1272
30	1122
40	942
50	744
60	547
70	365
80	216
90	113

CCT & Power Data Multiplier

	22W	28W	40W
3500K	0.644	0.807	1.000
4000K	0.732	0.919	1.138
5000K	0.656	0.823	1.019

Cone of Light Tabulation

Mounted height (Feet)	Footcandles Beam Center	Diameter (Feet)
8	21.8	9.5
10	13.9	11.9
12	8.8	15.3
16	5.4	19.0

Zonal Lumen Summary

Zone	Lumens	% of Luminaire
0-30	1085	21.1%
0-40	1773	34.6%
0-60	3166	61.7%
0-90	4485	87.4%
90-180	0	12.6%
0-180	5131	100%

Fixture tested per LM-79-08. Photometric data is of the performance of a representative fixture. Results may vary in the field.

LSCS 8' 3500K

Input Voltage (VAC)	120-277
System Level Power (W)	59.7
Delivered Lumens (Lm)	8082
System Efficacy (Lm/W)	135.4
Correlated Color Temp (K)	3411
Color Rendering Index (CRI)	81
Beam Angle (0)	138.8
Beam Angle (90)	104.9
Spacing Criteria (0)	1.2
Spacing Criteria (90)	1.3

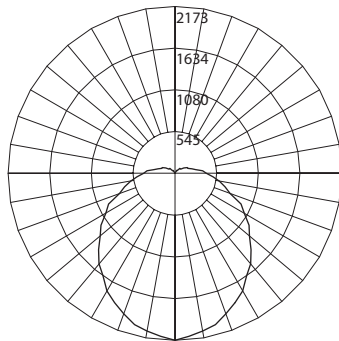

Intensity Summary (Candela Power)

Angle	Mean CP
0	2179
10	2141
20	2011
30	1804
40	1541
50	1241
60	924
70	609
80	338
90	153

CCT & Power Data Multiplier

3500K	1.000
4000K	1.138
5000K	1.019

Cone of Light Tabulation

Mounted height (Feet)	Footcandles Beam Center	Diameter (Feet)
8	34.1	9.7
10	21.6	12.2
12	15.1	14.6
16	8.5	19.4

Zonal Lumen Summary

Zone	Lumens	% of Luminaire
0-30	1690	25%
0-40	2775	40%
0-60	5007	69%
0-90	7166	93%
90-180	915	7%
0-180	8082	100%

Fixture tested per LM-79-08. Photometric data is of the performance of a representative fixture. Results may vary in the field.

Dimensions

Standard motion sensor adds 1.5" to one end of the fixture

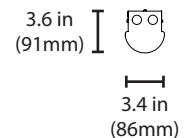
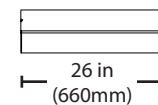
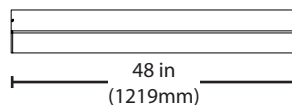
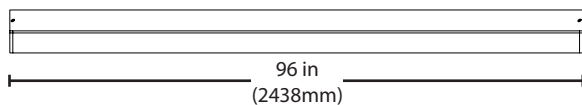

This device complies with part 15 of the FCC Rules. Operation is subject to the following two conditions: (1) This device may not cause harmful interference, and (2) this device must accept any interference received, including interference that may cause undesired operation.

NOTE: This equipment has been tested and found to comply with the limits for a Class A digital device, pursuant to part 15 of the FCC Rules. These limits are designed to provide reasonable protection against harmful interference when the equipment is operated in a commercial environment. This equipment generates, uses, and can radiate radio frequency energy and, if not installed and used in accordance with the instruction manual, may cause harmful interference to radio communications. Operation of this equipment in a residential area is likely to cause harmful interference in which case the user will be required to correct the interference at his own expense.