

RSDS-M

Surface Mount Downlight with PIR Motion Sensor

Product Description

The RSDS-M Surface Mount Downlight with PIR Motion Sensor is a sleek and efficient lighting solution that offers effortless automatic on/off control. With the convenience of selecting your preferred CCT (2700/3000/3500/4000/5000K) at the flip of a switch, this light adapts to your lighting needs with ease. Time control of the motion sensor provides another level of customization. The RSDS-M is ideal for providing uniform illumination and automatic controls in closets, pantries, and other similar spaces.

Construction

- Durable steel body
- Twist-lock diffuser allows for easy removal for installation

Optical System

- Molded polymer, UV stabilized diffuser maximizes light output.
- Convex diffuser creates uniform light distribution while reducing glare
- Offered in 5 CCT selection of 2700/3000/3500K/4000/5000K

Electrical

- Input voltage of 120VAC, 60Hz
- CCT switch located behind the lens for easy access after installation
- Integrated PIR motion sensor
- Motion Sensor delay time selectable via switch on the side (OFF/1min/5min/8min)
- Dimmable to 5% with compatible leading (TRIAC) and trailing edge (ELV) dimmers
- Operating temperature rating of -4°F to 104°F (-20°C to 40°C)

Finish

- White powder coat finish standard

Mounting and Installation

- Easy installation in any 4" pancake, 4" non-metallic or 4/O junction box
- Keyhole mounting slots allow for quick installation to junction boxes
- For installations where power surge may be possible, NICOR recommends installing additional surge protection at the electrical distribution panel

Listings

- cETLus 1598 Listed for wet locations
- ENERGYSTAR Downlights 1.0 Listed
- CA Title 24/JA8 Compliant
- Compliant with NFPA® 70, NEC® Section 410.16 (A)(3) and 410.16 (C)(5) for closet use
- RoHS Compliant
- Meets FCC Part 15, Subpart B, Class B standards for conducted and radiated emissions
- TM-21 Reported L70(9k) life >54,000 hours
- LM-79, LM-80 testing performed in accordance with IESNA standards

Warranty

- 5-year limited system warranty standard
- Warranty does not cover product failure due to an overvoltage event (power surge)

Project

Catalog

Type

Date



RSD6SM

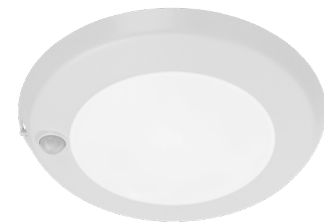

RSD4SM



RSD-M 4" and 6" Surface Mount Downlight with PIR Motion Sensor 800, 1200 lumen



RSDS-M

Surface Mount Downlight with PIR Motion Sensor

Ordering

Ordering Information

Example: RSD62120S9WHM

Series	Version	Voltage	CCT's	CRI	Trim Color	Sensor
RSD4	2	120	5 (Selectable 2700/3000/3500/4000/5000K)	9 (90+)	WH (White)	M
RSD6						

Specifications and dimensions subject to change without notice

Performance Data

Performance Data				
Model	CCT	Lumens	Watts	Lumens/Watt
RSD4	2700K	770	9.96	77.3
	3000K	785	9.98	78.7
	3500K	825	10.00	82.5
	4000K	837	9.97	84.0
	5000K	812	9.84	82.5
RSD6	2700K	1123	13.68	82.1
	3000K	1140	13.69	83.3
	3500K	1230	13.99	87.9
	4000K	1203	13.87	86.7
	5000K	1140	13.56	84.1

Recommended Dimmers*

Lutron Diva DVCL-153P
 Lutron Maestro MACL-153M
 Eaton Cooper SLC03P
 Leviton IPL06
 Lutron DIVA DVELV-300P

Housing Compatibility*

4" Pancake, 4" Non-Metallic or 4/O junction boxes

*Not a complete list. Check compatibility before installation.

Photometric Data

RSD4SM 3000K

Input Voltage (VAC)	120V
System Level Power (W)	10.0
Delivered Lumens (Lm)	785
System Efficacy (Lm/W)	78.7
Correlated Color Temp (K)	2966
Color Rendering Index (CRI)	96 R9=89
Beam Angle	110
Spacing Criteria	1.24

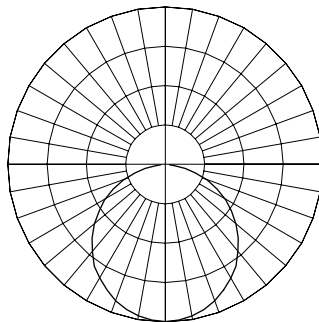

Intensity Summary (Candle Power)

Angle	Mean CP
0	1344
5	1400
15	1422
25	1497
35	1608
45	1527
55	1147
65	827
75	475
85	175
90	108

Cone of Light Tabulation

Mounted height (Feet)	Footcandles Beam Center	Diameter (Feet)
4	17.0	11.4
6	7.6	17.1
8	4.3	22.9
10	2.7	28.6

Zonal Lumen Summary

Zone	Lumens	% of Luminaire
0-30	209	26.7%
0-40	341	43.4%
0-60	598	76.1%
0-90	779	99.3%
90-180	6	0.7%
0-180	785	100%

Fixture tested per LM-79-08. Photometric data is of the performance of a representative fixture. Results may vary in the field.

CCT Data Multiplier

2700K	0.981
3000K	1.000
3500K	1.051
4000K	1.066
5000K	1.034

RSDS-M

Surface Mount Downlight with PIR Motion Sensor

Photometric Data

RSD6SM 3000K

Input Voltage (VAC)	120
System Level Power (W)	13.7
Delivered Lumens (Lm)	1140
System Efficacy (Lm/W)	83.3
Correlated Color Temp (K)	2936
Color Rendering Index (CRI)	96 R9=76
Beam Angle	110
Spacing Criteria	1.24

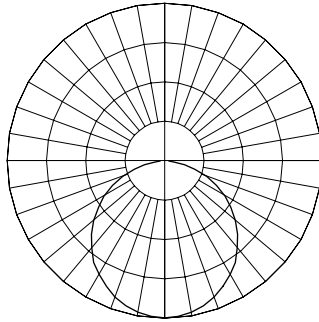

Intensity Summary (Candle Power)	
Angle	Mean CP
0	1344
5	1400
15	1422
25	1497
35	1608
45	1527
55	1147
65	827
75	475
85	175
90	108

Cone of Light Tabulation		
Mounted height (Feet)	Footcandles Beam Center	Diameter (Feet)
4	24.9	11.4
6	11.0	17.1
8	6.2	22.9
10	4.0	28.6

Zonal Lumen Summary		
Zone	Lumens	% of Luminaire
0-30	305	26.8%
0-40	496	43.5%
0-60	870	76.3%
0-90	1133	99.3%
90-180	7	0.7%
0-180	1141	100%

CCT Data Multiplier	
2700K	0.985
3000K	1.000
3500K	1.079
4000K	1.055
5000K	1.000

Fixture tested per LM-79-08. Photometric data is of the performance of a representative fixture. Results may vary in the field.

Dimensions and Sensor Information

RSD4SM

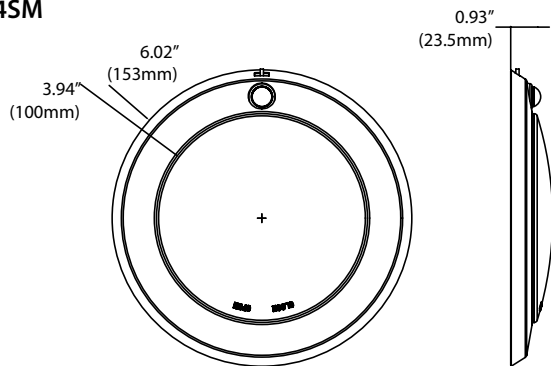

RSD6SM

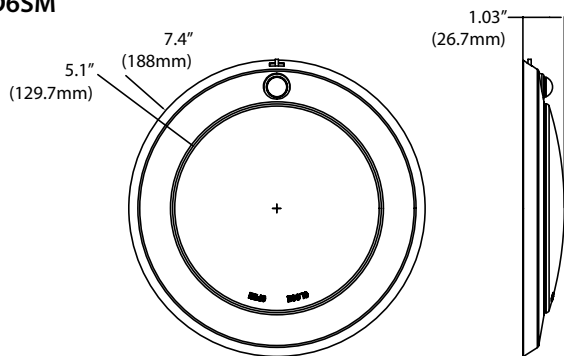

Maximum sensor detection distance = 16ft

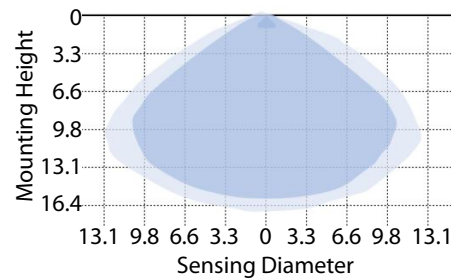

This device complies with part 15 of the FCC Rules. Operation is subject to the following two conditions: (1) This device may not cause harmful interference, and (2) this device must accept any interference received, including interference that may cause undesired operation. NOTE: This equipment has been tested and found to comply with the limits for a Class B digital device, pursuant to part 15 of the FCC Rules. These limits are designed to provide reasonable protection against harmful interference in a residential installation. This equipment generates, uses and can radiate radio frequency energy and, if not installed and used in accordance with the instructions, may cause harmful interference to radio communications. However, there is no guarantee that interference will not occur in a particular installation. If this equipment does cause harmful interference to radio or television reception, which can be determined by turning the equipment off and on, the user is encouraged to try to correct the interference by one or more of the following measures:
 —Reorient or relocate the receiving antenna.
 —Increase the separation between the equipment and receiver.
 —Connect the equipment into an outlet on a circuit different from that to which the receiver is connected.
 —Consult the dealer or an experienced radio/TV technician for help.

