

NOTES:
 1. MATERIAL: .015 TK BRIGHT 430 STAINLESS STEEL

CUSTOMER DRAWING

This drawing is the property of Rev-A-Shelf (RAS) and is disclosed in confidence to the extent its subject matter is original to RAS. Any vendor receiving this drawing from RAS shall hold and use this drawing for the sole benefit of RAS and shall not disclose it to, or use or reproduce it for any third party, or perform any act adverse to the interest of RAS with respect to this drawing without the express written permission of RAS. Vendors shall not revise any physical, dimensional or performance characteristic unless authorized by Rev-A-Shelf Engineering.

REV.	DATE	BY	DESCRIPTION OF CHANGE

INCH [MM]	AMERICAN PROJECTION	DRAWN	BY	DATE	REV-A-SHELF, INC.
			BKT	7/29/14	
TOLERANCES		MATERIAL	DRAWING NO.		SCALE
MAT.	DEC.		6541-20-1300		0.750
(WOOD)	.XX ±.03 [.8mm]	FINISH	PART NO.		SHEET OF
(OTHER)	.XX ±.02 [.5mm]		6541-20-1300		
(ALL)	.XXX ±.005 [.13 mm]				
FRACTIONS	±1/32 [.8 mm]				
ANGLES ±1/2°					

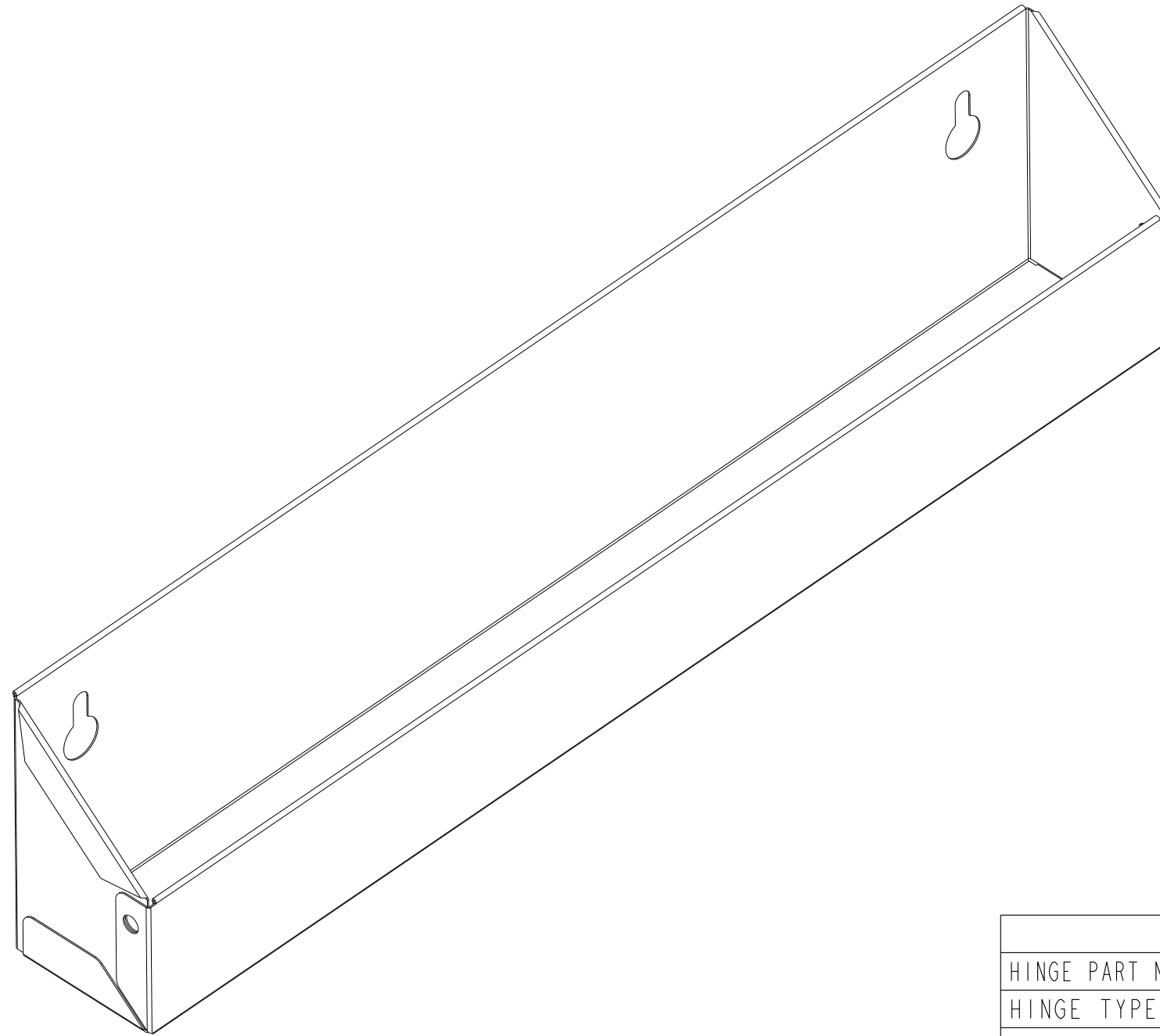

PART DIMENSIONS	
WIDTH	13.00 [330,2]
DEPTH *	1.69 [43,1]
HEIGHT **	3.00 [76,2]

* DEPTH W/ SELF-HOLDIN HINGES: 1.77 [45]
 ** HEIGHT W/ SELF-HOLDIN HINGES: 3.80 [96,5]

MIN CABINET OPENING ***				
	FACE FRAME	FRAMELESS	INSET FACE FRAME	INSET FRAMELESS
WIDTH	15.25 [387]	15.25 [387]	15.25 [387]	15.25 [387]
DEPTH	2.00 [50,8]	2.00 [50,8]	2.75 [69,9]	2.75 [69,9]
HEIGHT	3.88 [98,4]	3.88 [98,4]	3.88 [98,4]	3.88 [98,4]

*** MCO BASED ON SELF-HOLDIN HINGES

HINGE SPECIFICATIONS				
HINGE PART NUMBER	HA 94-MZ	RELEASE PART NUMBER	N/A	MAX WEIGHT RATING
HINGE TYPE	PIVOT	HINGE EXTENSION	45°	
HINGE CLOSING	N/A	HINGE LENGTH	N/A	
HINGE MOUNTING	SIDE	HINGE FINISH	ZINC	

CUSTOMER DRAWING

This drawing is the property of Rev-A-Shelf (RAS) and is disclosed in confidence to the extent its subject matter is original to RAS. Any vendor receiving this drawing from RAS shall hold and use this drawing for the sole benefit of RAS and shall not disclose it to, or use or reproduce it for any third party, or perform any act adverse to the interest of RAS with respect to this drawing without the express written permission of RAS. Vendors shall not revise any physical, dimensional or performance characteristic unless authorized by Rev-A-Shelf Engineering.

REV.	DATE	BY	DESCRIPTION OF CHANGE

INCH [MM]	AMERICAN PROJECTION	DRAWN	BY	DATE	REV-A-SHELF, INC.
			BKT	7/29/14	
			MATERIAL	DRAWING NO.	SCALE
			FINISH	6541-20-1300	0.750
				PART NO.	SHEET OF
				6541-20-1300	2 2

TOLERANCES
 MAT. DEC.
 (WOOD) .XX ±.03 [8mm]
 (OTHER) .XX ±.02 [5mm]
 (ALL) .XXX ±.005 [13 mm]
 FRACTIONS ±1/32 [8 mm]

ANGLES
 ±1/2°