

# ***AFD82***

## **Adjustable Force Device Manual**



***PUSHCORP, INC.***

**Dallas, Texas**

January, 2003

**HANDLE WITH CARE  
DO NOT DROP**

**DO NOT USE LUBRICATED AIR.**

**This device requires a dry, non-lubricated 80 psi (5.5 bar) maximum air supply filtered to 5  $\mu$ m and a 0.3 micron oil mist separator.**

**Non-compliance with these requirements will void the manufacturer's warranty.**

**(See Section 4.4)**

**All fasteners, mounting holes and pipe threads on this tool are  
METRIC.**

**All *PushCorp, Inc.* electrical cables are rated for high twist and flex robotic applications with a minimum cable bending radius specification of 125mm (5 in). Cable damage resulting from failure to abide by this specification will not be covered under warranty.**

Table of Contents

**1.0 LIMITED WARRANTY.....2**

**2.0 GENERAL OVERVIEW.....4**

**3.0 INSTALLATION.....4**

3.1 Mounting Process Equipment..... 4

3.2 Mounting the *AFD82*..... 6

3.2.1 Mounting the AFD80-1 Vertical and AFD80-2 Horizontal.....7

3.2.2 Mounting the AFD80-3 Table Top..... 8

3.3 Maximum Carriage Load Calculations..... 9

3.4 Pneumatic Connection..... 11

3.5 Internal Air Cartridge Filter..... 12

**4.0 ADJUSTING CARRIAGE PRELOAD..... 13**

**5.0 ELECTRICAL CONNECTIONS..... 15**

5.1 Carriage Position Feedback Connection..... 15

**6.0 ACHIEVING DESIRED FORCE..... 17**

**7.0 TECHNICAL SPECIFICATIONS..... 19**

**8.0 PREVENTATIVE MAINTENANCE SCHEDULE.....20**

## **1.0 Limited Warranty**

### **Duration:**

One year from date of delivery to the original purchaser.

### **Who gives this warranty (warrantor):**

*PushCorp, Inc.*

Telephone: (972) 840-0208

Corporate Address:

P. O. Box 181915

Dallas, Texas 75218

Shipping Address:

3001 W. Kingsley Rd.

Garland, Texas 75041

### **Who receives this warranty (purchaser):**

The original purchaser (other than for purposes of resale) of the *PushCorp, Inc.* product

### **What products are covered by this warranty:**

Any *PushCorp, Inc.* Adjustable Force Device or Adjustable Force Device accessory supplied or manufactured by the Warrantor.

### **What is covered under this warranty:**

Defects in material and/or workmanship which occur within the duration of the warranty period.

### **What is NOT covered in this warranty:**

- A. IMPLIED WARRANTIES, INCLUDING THOSE OF MERCHANT-ABILITY AND FITNESS FOR A PARTICULAR PURPOSE ARE LIMITED TO ONE YEAR FROM THE DATE OF ORIGINAL PURCHASE. Some states do not allow limitations on how long an implied warranty lasts, so the above limitations may not apply to you.
- B. ANY INCIDENTAL, INDIRECT, OR CONSEQUENTIAL LOSS, DAMAGE or EXPENSE THAT MAY RESULT FROM ANY DEFECT, FAILURE, MALFUNCTION OF THE *PUSHCORP, INC.* PRODUCT. Some states do not allow the exclusion or limitation of incidental or consequential damages so the above limitation or exclusion may not apply to you.
- C. Any failure that results from an accident, purchaser's abuse, neglect, unauthorized repair or failure to operate the products in accordance with the instructions provided in the owner's manual(s) supplied with the product.

### **Responsibilities of the Warrantor under this warranty:**

Repair or replace, at Warrantor's option, products or components which have failed within the duration of the warranty period.

**Responsibilities of the purchaser under this warranty:**

- A. Deliver or ship the *PushCorp, Inc.* product or component to PushCorp, Inc. Service Center, Dallas, TX. Freight and insurance costs, if any, must be borne by the purchaser.
- B. Use reasonable care in the operation and maintenance of the product as described in the owner's manual(s).

**When warrantor will perform repair or replacement under this warranty:**

Repair or replacement will be scheduled and serviced according to the normal work flow at the service center, and depending on the availability of replacement parts. Purchasers requiring quicker repair may receive such with payment of a *PushCorp, Inc.* predetermined expediting fee.

This Limited Warranty gives you specific legal rights and you may also have other rights which vary from state to state.

## 2.0 General Overview

The *PushCorp, 80 Series* Passive AFD was designed as a low cost alternative to the *1100 Series* Active Force Device. As such the *80 Series* is a very basic unit that still incorporates several innovative features. To reduce operating friction and increase force accuracy the *80 Series* uses glass pneumatic cylinders with graphite pistons, and linear ball bearings. It has two robot mounting configurations, and a table top mounting configuration. The *80 Series* may be supplied to apply only a positive force, the AFD81, or both positive and negative forces, the AFD82.

The *80 Series* requires the user to supply at least one pressure regulator to control the force output. If an AFD82 is specified then two regulators are required. The device's low friction components mean that the force output resolution and repeatability is highly dependent on the regulator accuracy. The regulator can be manual or electrically adjustable based on the user's application requirements. If only one force level is required and the AFD orientation does not change, a manual regulator is sufficient. If the force and/or AFD orientation changes during the process, then an electrically controlled proportional regulator is required. In some cases the process equipment weight must be taken into account so that a constant force can be applied regardless of the AFD orientation. This situation requires calculation of the regulator pressure based on the process equipment weight and AFD orientation. To monitor the Carriage position the AFD82 must be connected to a DC power source and an analog input device through a PushCorp high-flex cable.

All these features combine to make the *PushCorp 80 Series* Adjustable Force Devices rugged, reliable devices capable of delivering consistent results in any number of industrial applications.

## 3.0 Installation

### 3.1 Mounting Process Equipment

The AFD82 Adjustable Force Device can accommodate many different types of process equipment. PushCorp provides a variety of standard process equipment such as weld shavers, high speed motors, belt sanders, and other specialized tooling. Many end users also develop process equipment for their own proprietary applications. The AFD can be oriented parallel or perpendicular to the manipulator mounting flange, although it is important to note that the AFD can apply force only in the direction of Carriage translation.

When mounting process equipment to the Carriage extreme care should be taken while designing and installing the brackets. Correctly designed brackets will increase the stiffness of the Carriage by becoming an external superstructure for the Carriage. The Carriage can gain a tremendous amount of rigidity if this approach is executed correctly. Incorrectly designed bracketry will deform the Carriage causing internal Linear Rail misalignment. A symptom of Carriage deformation is "slop" or "binding" of the Carriage. A deformed or loose Carriage will damage the Linear Rails and effect the consistency of your process. The Carriage preload is correctly set at the factory and should not require adjustment. If the Carriage becomes loose or binds after installing the process

equipment, then the brackets must be removed and the problem corrected. *PushCorp, Inc.* can design and fabricate brackets to user supplied specifications as an option.

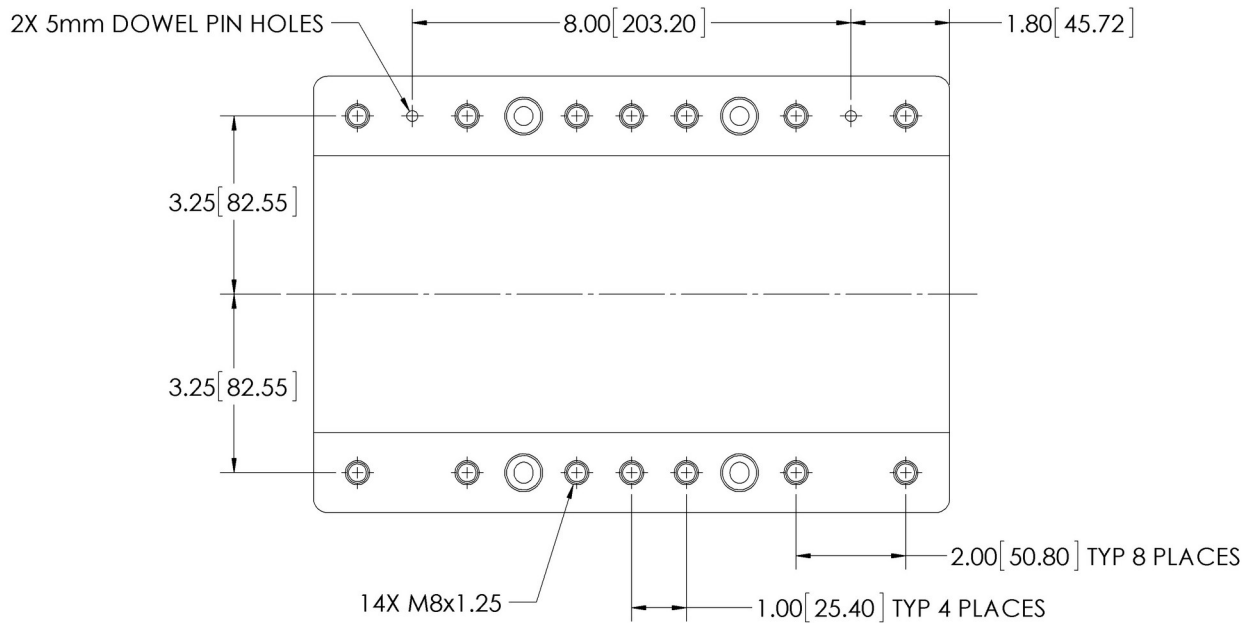

Figure 1: Carriage bolt hole pattern

The bolt pattern on the Carriage has been designed to facilitate process equipment installation. The Carriage has (14) fourteen M8x1.25 mounting holes with a depth of 0.52 inch (13 mm) to provide secure attachment points. The mounting holes are spaced as shown in Figure 1. The Carriage also has (2) two 5mm dowel pin holes to facilitate alignment. (See Figure 1 for location) These dowel pin holes are oversized to allow the pins to be glued into place using Loctite 609, or equivalent. **Only utilize 4 of the M6x1 mounting holes; using more than 4 may cause warping of the carriage.**

Care must be taken when designing and manufacturing brackets that will be mounted to the linear carriage. It is essential that these brackets maintain a face to face parallelism of at least 0.001" in order to prevent binding, which can lead to inaccurate applied force. As a result, we recommend using tooling plate for the stock material or blanchard grinding the mounting faces.

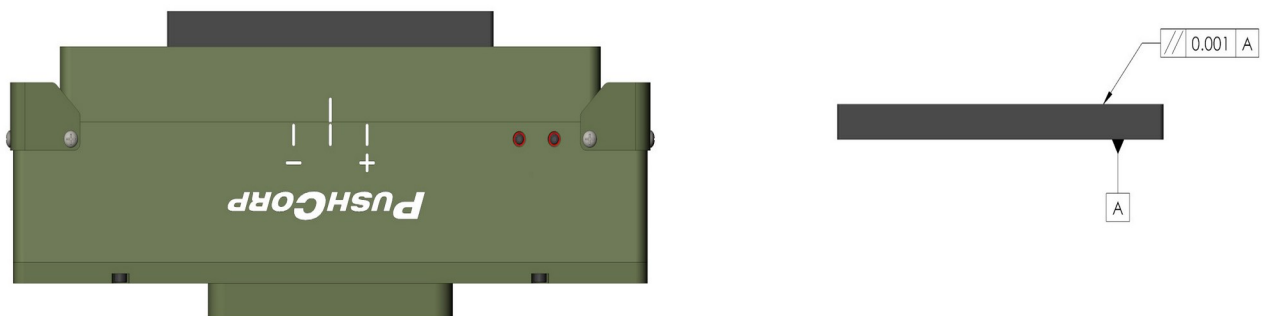

Figure 2: Carriage Mount Bracket - Parallelism

If these options are not practical for your design, machined steps or the use of shims under bolted surfaces are also suitable. We recommend a height of 0.02” to ensure enough clearance between the carriage and the mounting plate.

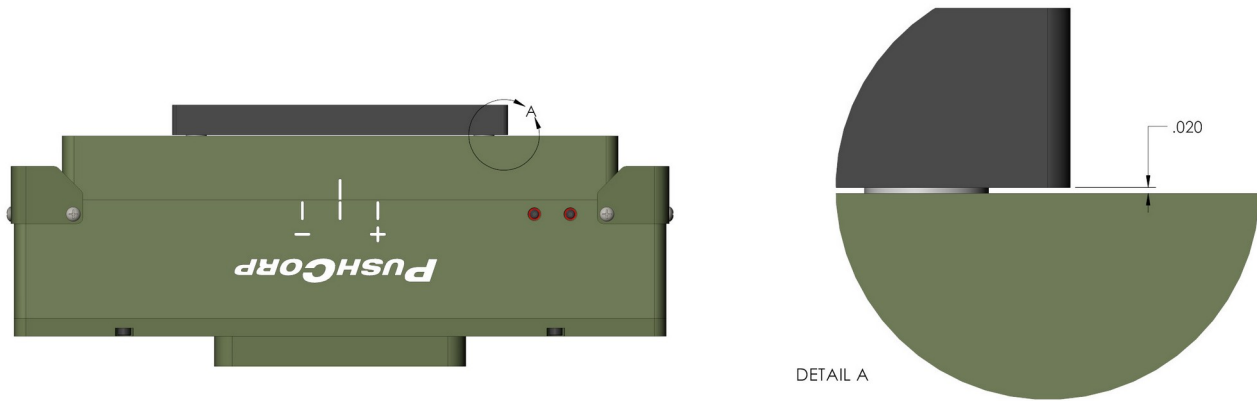

Figure 3: Carriage Mount Brackets - Shims

**WARNING: DO NOT** press pins into the AFD Carriage as this will damage the Linear Rails.

**CAUTION:** The Fastener Tightening Torque Specs chart in Section 6.0 should be used to determine proper fastener length and torque for fasteners into the Carriage. This is to prevent pull-out of the Carriage helicoil inserts. Fasteners must not exceed a depth of 0.52 inches (13 mm) into the Carriage as this could damage the Linear Rails.

### 3.2 Mounting the AFD82

The basic configuration of the AFD82 force device allows attachment to a stationary fixture or a robotic manipulator mounting flange. Specifying an AFD80 -1, -2, or -3 determines which Mounting Bracket is supplied. Adapter plates or "quick-change" attachments can be used as well for mounting. The AFD82 has (2) two 4mm dowel pins pressed into the base for location and alignment of the cover and Mounting Bracket.



**3.2.1 Mounting the AFD80-1 Vertical and AFD80-2 Horizontal**

The *AFD80-1* and *AFD80-2* are supplied with a standard Mounting Bracket shown in Figure 4. A minimum of (3) three holes should be utilized to secure the Mounting Bracket to the robot mounting flange.

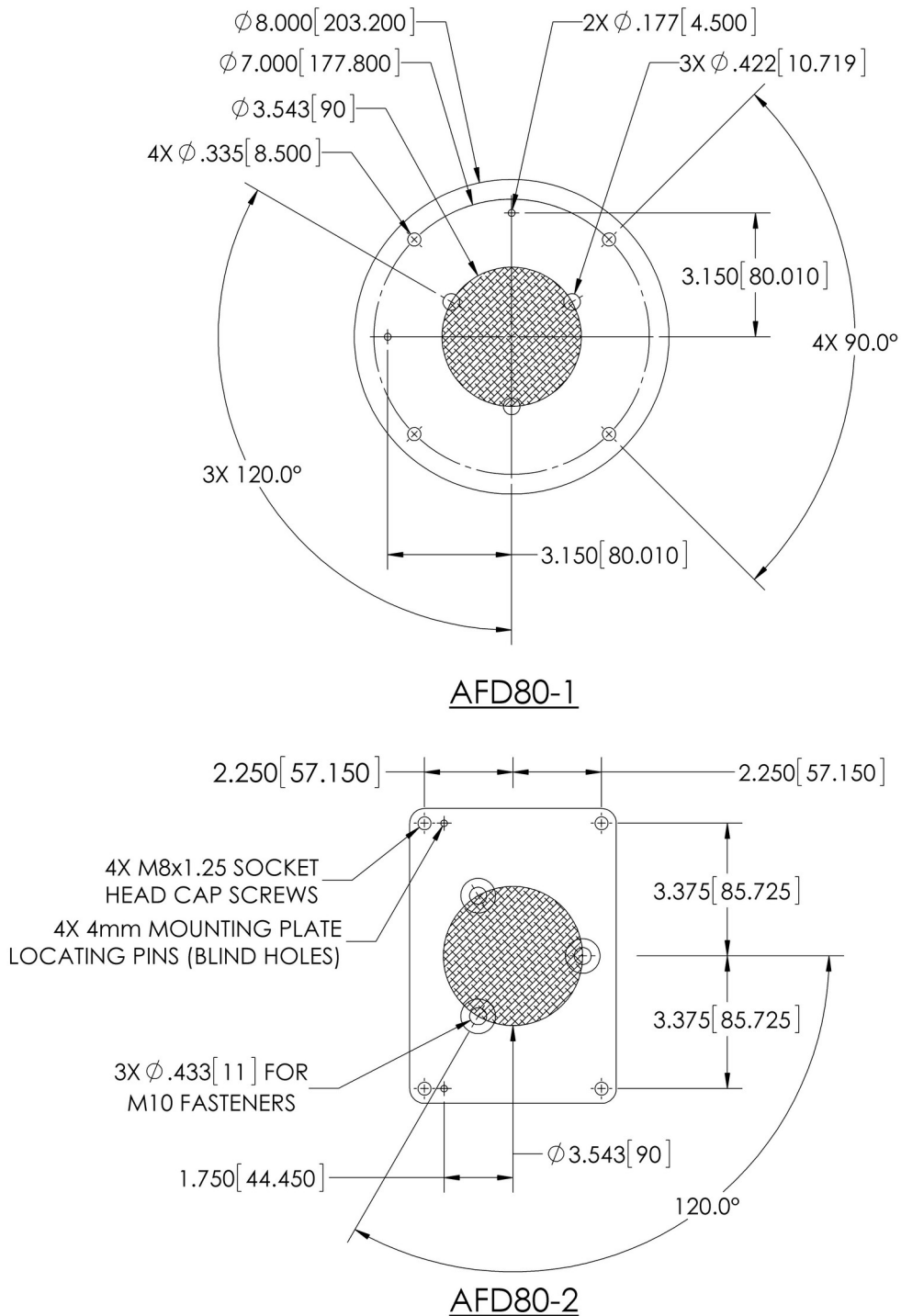

Figure 4: AFD80-1 and AFD80-2 Mounting Brackets

If the Mounting Bracket is supplied blank or additional holes are required, it must first be removed from the device before drilling. (4) Four M8x1.25 Socket Head Cap Screws are used to attach the Mounting Bracket to the *AFD82* force devices. Once the Mounting Bracket is removed, mounting holes may be placed anywhere within the crosshatched area shown in Figure 4. *PushCorp, Inc.* will supply engineering support to determine the mounting hole locations at no cost.

After drilling the required hole pattern, remove any burrs and clean any machining residue from the Mounting Bracket. The Mounting Bracket can then be reattached.

### 3.2.2 Mounting the AFD80-3 Table Top

The AFD80-3 is designed for mounting on a stationary fixture. It has five (5)  $\text{Ø}0.33''$  ( $\text{Ø}8.4$  mm) mounting holes spaced as shown in Figure 5; the three holes denoted by "standard mounting" should be used for optimal mating between the AFD mounting bracket and the stationary fixture. This setup will help prevent the carriage from binding and effecting the output force.

For legacy customers using the 4 hole pattern, 2 standoffs are provided in the fitting kit. These can be added to the counterbores in the corners to get the plate level and make it backwards compatible with the previous 4 point contact design. The AFD80-3 Table Top Mounting Bracket should not be modified without first consulting *PushCorp, Inc.* For the 4 hole pattern mounting configurations, the surface that the plate is being mounted to should be  $.003''$  per foot to avoid distorting the base.

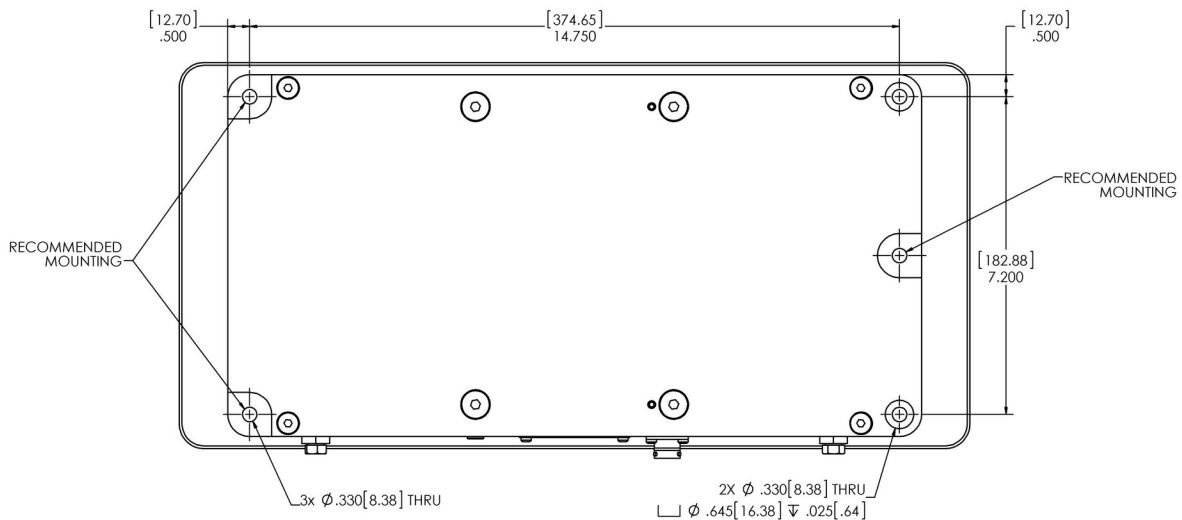
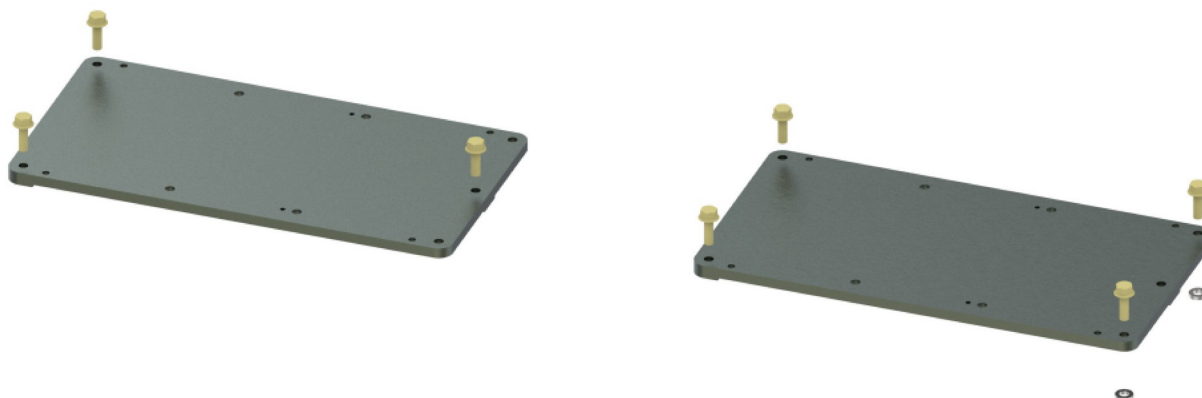

Figure 5: AFD80-3 Mounting Bracket hole locations



AFD80-3 Three Point Contact  
RECOMMENDED MOUNTING

AFD80-3 Four Point Contact

Figure 6: AFD80-3 Mounting Bracket hole locations

### 3.3 Maximum Carriage Load Calculations

The Linear Rail bearings that support the *AFD82* Carriage have been selected to provide optimal performance with respect to capacity, size, and low friction. To ensure continued optimal performance it is very important not to overload these bearings. The following diagrams and associated equations are provided to check your application for excessive loading.

It is important to note that these equations require the use of Metric units. The necessary conversions are provided for your convenience. Insert your maximum applied force and process equipment weight (*W*) and overhang distances (*D*) to calculate an actual bearing load (*L*) that must be less than the maximum bearing load shown on the right side of the equation. The life of the bearings is 100,000 meters of linear motion, at the maximum allowable bearing load value. Exceeding this value (*L*) will reduce the life, and operating at less than this value (*L*) will increase the life. It is common to have combined weight and force loads on the Carriage. These situations may require adding two or more of the scenarios shown below. If your application is not similar to any of the designs listed here, or if the information is not clear, please contact *PushCorp* Technical Support for assistance.

If AFD was purchased before January 2023, refer to the document located at: <https://pushcorp.com/product/obsolete-products/> for appropriate carriage load calculations.

W= Maximum Force (N) (max. applied force + process equipment weight)

D= Load Overhang distance (mm)

1 lbf. = 4.45 N

L= Bearing Load (N)

1 in. = 25.4 mm

⊕ = Concentrated Load Position

1 N = 0.102 kg

**CASE 1**

$$L = W \left( \frac{D}{263.2} + 0.81 \right) < 6050$$

**CASE 2**

$$L = \frac{W}{4} < 6050$$

**CASE 3**

$$L = W \left( \frac{D+26.5}{263.2} \right) < 6050$$

### 3.4 Pneumatic Connection

The AFD82 Adjustable Force Devices require a dry, non-lubricated, 5  $\mu\text{m}$  filtered, 80 psi (5.5 Bar) maximum air supply. Failure to provide supply air to these specifications can degrade performance and will void any warranty repairs concerning pneumatic components. Filtered air is required to prevent foreign material from entering the AFD.

The pneumatic supply system should be configured as shown in the Figure 7.

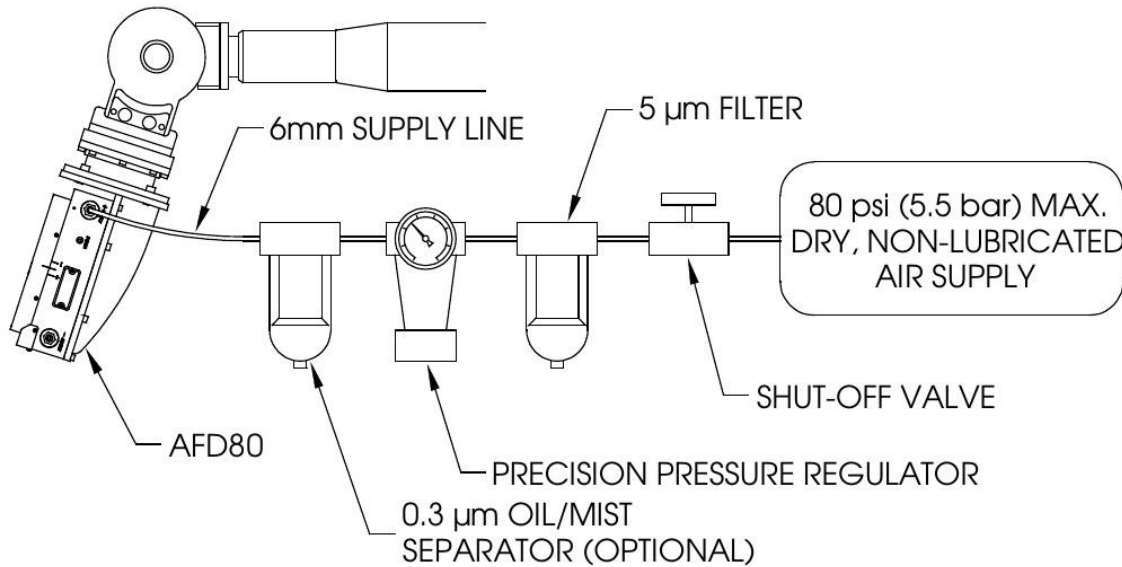

Figure 7: Pneumatic configuration

To apply force in the positive + direction, on an AFD81 or AFD82, a Supply Line must be connected to the + Supply Air Port. To apply force in the negative - direction, on an AFD82, a Supply Line must be connected to the - Supply Air Port.

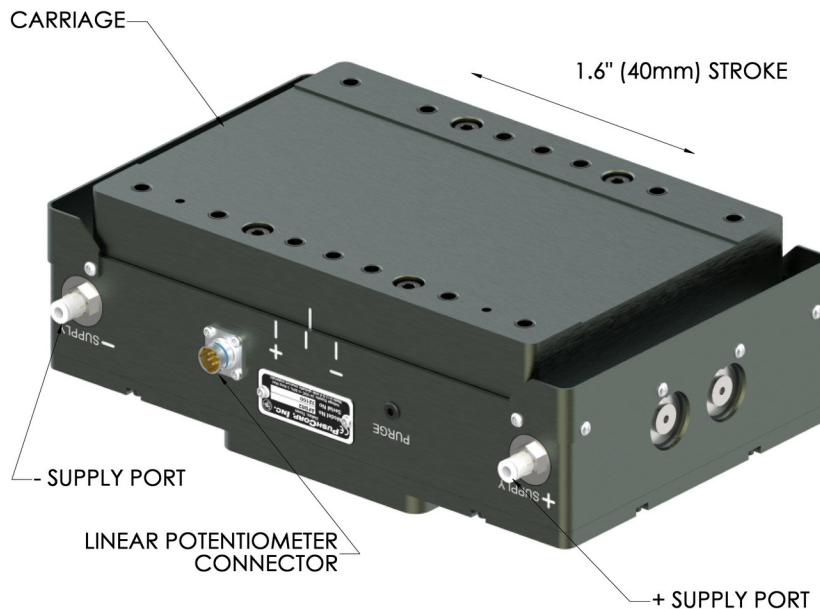

Figure 8: 80 Series air connections

If water condensation is a problem in your air supply system, an air dryer device is highly recommended. The ideal solution is an industrial chiller dryer capable of reducing the dewpoint to less than 32° F (0°C). Moisture inside the AFD will cause premature failure that will not be covered under warranty.

In applications where the environment contains suspended particulate matter purge air flow must be used to ensure that the AFD remains clear of foreign matter. A Purge Port on the *AFD82* (See Figure 8.) provides a pneumatic connection to supply this air flow. The port accepts a metric R 1/8 tapered pneumatic fitting. PushCorp can provide fittings for english or metric tubing. The input pressure to the purge port can range from 10 PSI to 60 PSI (0.7 – 4.1 bar) with a flow rate of 0.5 to 2.0 SCFM (14 – 56 l/min) depending on the application. The purge air must be dry and non-lubricated, however it need only be filtered to 20 microns.

The Supply Line and Purge Line to the device should be 1/4 inch or 6mm diameter flexible polyurethane tubing. The tubing should be routed to the AFD such that there are no kinks and that there is plenty of slack to allow for manipulator motion. Before inserting the Supply Line or Purge Line into the force device air fitting, open the Shut-Off valve to blow out any contaminants which may be in the line. The tubing can now be pushed into the self-locking fitting located on the side of the AFD. Charge the Supply Line with compressed air and verify that there are no air leaks.

**NOTE: PushCorp highly recommends the use of flexible polyurethane tubing as opposed to nylon tubing. This is because nylon tubing tends to crimp shut when it is bent. This severely limits air flow to the AFD and causes instability.**

To remove the Supply Line, first discharge all air pressure in the system, then while pushing inward on the fitting's plastic ring, simultaneously pull the tubing out. Cover or plug the self-locking fitting any time the Supply Line or Purge Line is not connected. This will keep any contaminants from entering the AFD.

### **3.5 Internal Air Cartridge Filter**

The *AFD82* force device contains a Cartridge Filter in the base housing. The Cartridge Filter is designed to be the last line of defense to protect the AFD from contamination. The Cartridge Filter is not designed to be the sole means of AFD supply air filtration. The pneumatic supply system must be configured as described in Section 3.4. If the filter becomes clogged the *AFD82* will not function properly. Replacement Cartridge Filters may be purchased from PushCorp (Part No. PAR01943-1), or from the manufacturer directly (Parker, Part No. 050-05-DQ). To remove the Cartridge Filter loosen the Cartridge Filter Holder located on the side of the AFD base housing, See Figure 8. Remove the Cartridge Filter and perform a visual inspection. The condition of the Cartridge Filter will give an indication of the quality of your supply air system. Place a new Cartridge Filter on the Cartridge Filter Holder and insert them into the AFD base housing. Tighten the Cartridge Filter Holder to a torque of 90 lb-in. (10.2 N-m).

## 4.0 Adjusting Carriage Preload

The required preload on the AFD82 Linear Rails has been set at the factory for optimal performance and, in general, should not require field adjustment. However, there are situations that could arise that cause the Linear Rails to need adjustment. Often a loose, or tight, Carriage on a new AFD is indicative of an improperly designed process equipment bracket. If the problem disappears when the brackets are removed then this is the case. Normally the Carriage will only require adjustment after removal for field service.

To check for a loose Carriage, attempt to move the Carriage in a lateral direction as shown in Figure 9. If the Carriage moves or seems to exhibit any "slop", then the Linear Rail preload must be readjusted. A dial indicator is helpful, but not necessary to diagnose and correct a loose Carriage.

A Carriage that is too tight will require additional force to move. This is often detected during the weighting of the process equipment mounted on the Carriage. The weight will be inconsistent, varying higher or lower each time the process equipment is weighed.

The Linear Rails are attached to the underside of the Carriage with (4) four M8x1.25 Socket Head Cap Screws. Located on the side of the Carriage are the two Preload Adjustment Set Screws used to translate the Movable Linear Rail. Moving the Linear Rail associated with the Preload Adjustment Set Screws is all that is necessary to adjust the Carriage preload.

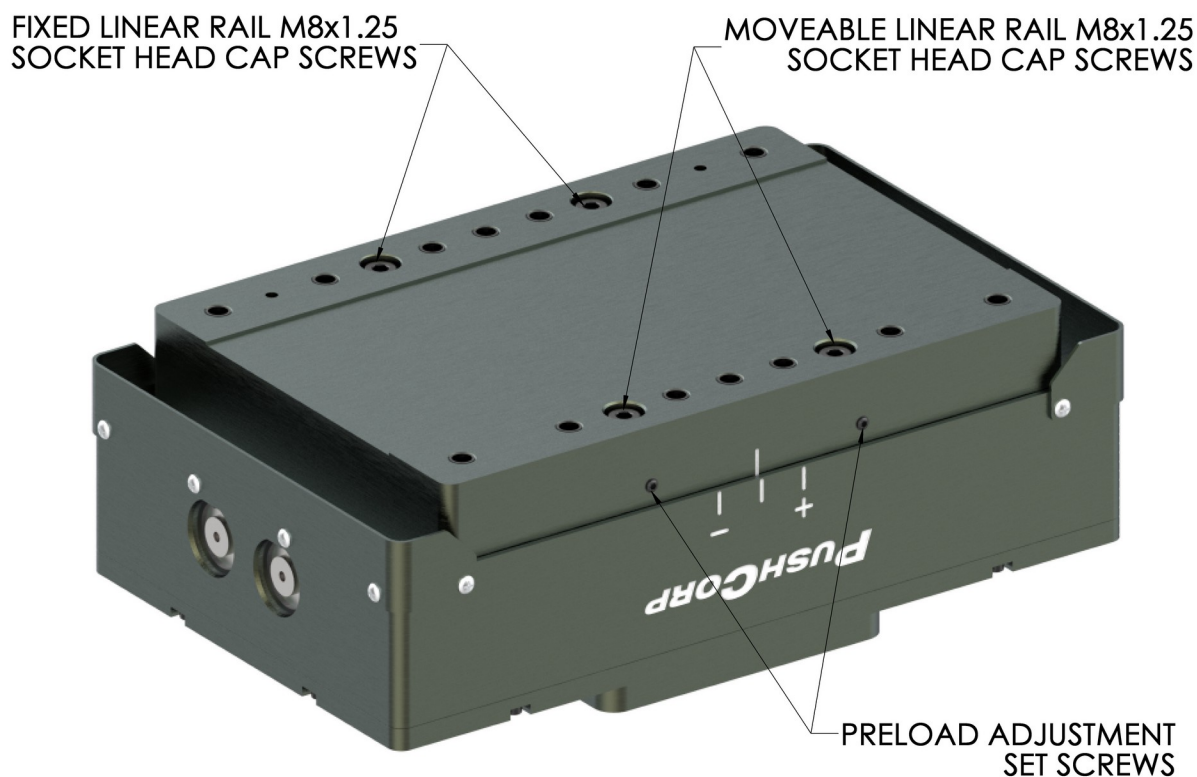

Figure 9: Carriage Preload adjustment

To perform the preload adjustment, follow the procedure below:

1. Check the tightness of the (2) two Fixed Linear Rail M8x1.25 Socket Head Cap Screws holding the Fixed Linear Rail opposite the Movable Linear Rail. If these fasteners are loose then the Fixed Linear Rail must be seated against the flange inside the Carriage. To do this, loosen all (4) four fasteners located on the face of the Carriage just enough to allow the Linear Rails to move. Next tighten the Preload Adjustment Set Screws to force the Fixed Linear Rail to seat against the flange. Tighten the (2) two Fixed Linear Rail M8x1.25 Socket Head Cap Screws, which hold the Fixed Linear Rail, to the torque specified in Section 6.0. The Fixed Linear Rail is now correctly seated and the Preload Adjustment Set Screws can be loosened. You are now ready to continue on to preload the Carriage Linear Rails.
2. To preload the Carriage Linear Rails, loosen the Movable Linear Rail M8x1.25 Socket Head Cap Screws holding the Movable Linear Rail only enough to allow the rail to move relative to the inside Carriage surface. The Carriage has slotted holes on the Movable Linear Rail side which allow the rail to move in the same direction as the Preload Adjustment Set Screws. Make sure that the Movable Linear Rail M8x1.25 Socket Head Cap Screws are loose before attempting to set the preload.
3. If a dial indicator is available, place it against the Carriage surface that contains the Preload Adjustment Set Screws. Attempt to move the Carriage laterally while monitoring the dial indicator. If the reading on the dial indicator varies, then gradually tighten each of the Preload Adjustment Set Screws. Note that one of the Preload Adjustment Set Screws could require more adjustment than the other. When the dial indicator ceases to vary, the preload is set correctly. Do not continue to tighten the Preload Adjustment Set Screws. Too much preload on the Linear Rails will cause excessive friction resulting in force errors.
4. If a dial indicator is not available, the preload can be adjusted by feel. Attempt to move the Carriage laterally and feel for movement. If the Carriage moves rotate each of the Preload Adjustment Set Screws no more than 5 degrees. As soon as no lateral movement can be felt, stop rotating the Preload Adjustment Set Screws. Note that one of the Preload Adjustment Set Screws could require more adjustment than the other. Do not over tighten the Preload Adjustment Set Screws. Over tightening the Preload Adjustment Set Screws will result in excessive friction and possible deformation of the Carriage. (If the adjustment cannot be performed, contact the factory service center.)

The Carriage preload should now be correct.

5. After verifying that the Carriage no longer moves laterally, tighten the (2) two Movable Linear Rail M8x1.25 Socket Head Cap Screws on the Moveable Rail side to the torque specified in Section 6.0..



## 5.0 Electrical Connections

### 5.1 Carriage Position Feedback Connection

The *AFDAFD82* comes equipped with an internal potentiometer that provides a voltage signal based on the linear motion of the Carriage. The voltage signal is at a minimum when the Carriage is in the full negative position and a maximum when the Carriage is in a full positive position. A High-Flex Cable is used to connect the +24VDC supply, and analog signals to the force device. The connector is specially designed to minimize strain on the cable. The plug and socket is configured to make it impossible to connect them incorrectly.

The linear position signal must be calibrated for each installation. User calibration is easily accomplished using the following steps.

1. Attach the High-Flex Cable to the Carriage Position Feedback Connector.
2. Attach the High-Flex Cable wires as shown in Figure 10.
3. Move the Carriage to the full negative position.
4. Read the voltage signal on the **POSN** *Position Signal* output. Record this voltage for future reference. This will be referred to as  $V_{neg}$ .
5. Move the Carriage to the full positive position.
6. Read the voltage signal on the **POSN** *Position Signal* output. Record this voltage for future reference. This will be referred to as  $V_{pos}$ .
7. The position of the Carriage can now be determined by measuring the current voltage on the **POSN** *Position Signal* output ( $V_m$ ) and inserting the value into the following equation:

$$p = 1.6 \text{ in.} \times \left( \frac{V_m - V_{neg}}{V_{pos} - V_{neg}} \right) \text{ (English units)}$$

$$p = 40 \text{ mm} \times \left( \frac{V_m - V_{neg}}{V_{pos} - V_{neg}} \right) \text{ (Metric units)}$$

Where,

$p$  = Carriage Position (in. , mm)

$V_m$  = Voltage measured on POSN signal wire (V)

$V_{neg}$  = Calibrated voltage at fully negative Carriage position (V), (0 inch, 0 mm)

$V_{pos}$  = Calibrated voltage at fully positive Carriage position (V), (1.6 inch, 40 mm)

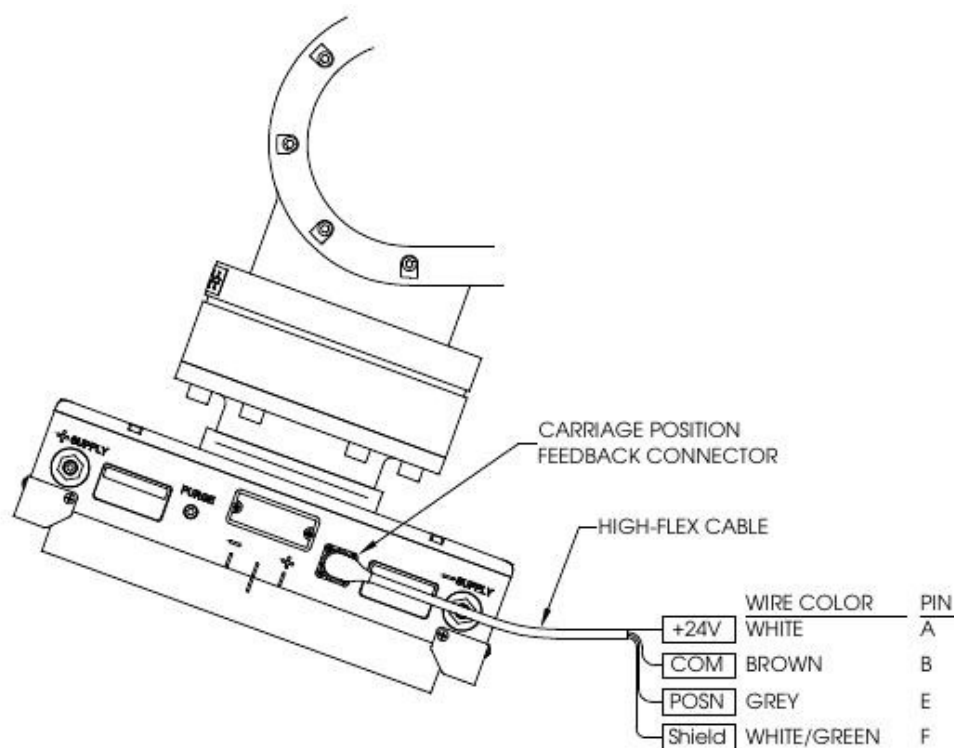

Figure 10: Electrical Connections

- +V** *Supply Voltage* - The supply voltage input for the AFD82. The supply should be well regulated to +/- 10%. The load resistance is 3000  $\Omega \pm 30\%$ . The supply voltage should not exceed 24VDC.
- COM** *Supply Common* - The supply common input for the AFD82. It should be connected to the common terminal for the supply as well as the analog common for the position signal.
- POSN** *Position Signal* - The linear potentiometer signal output. This voltage signal represents the Carriage position. The device connected to this output should have an input impedance of equal to or greater than 100k $\Omega$ . The linear potentiometer signal is not calibrated from the factory but is linear to  $\pm 1.0\%$ .
- SHLD** *Cable Shield* - The drain wire for the overall cable shield. Connect this wire to the central grounding point of the panel.

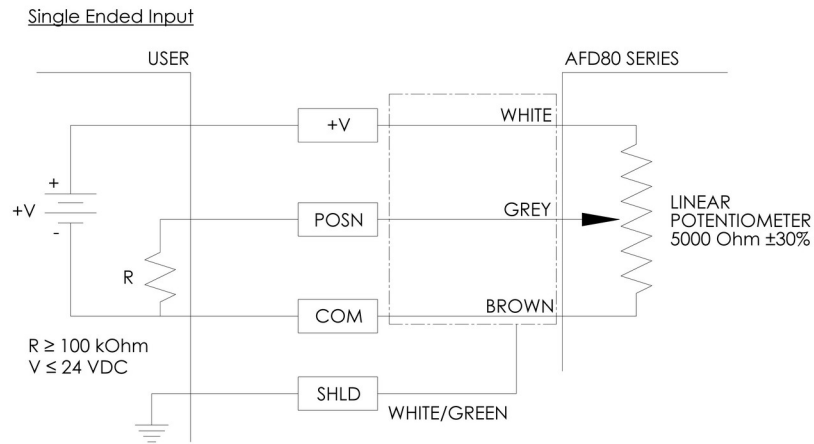

Figure 11: Linear Potentiometer Signal Connection

**NOTE: Care should be taken to ensure that all signal and voltage source commons are connected together on the user end to avoid D.C. offset errors.**

## 6.0 Achieving Desired Force

The *AFD82* is a passive force device that requires the user to provide pressure to the pneumatic actuators. Pressure in the actuators results in an output force at the Carriage. If the AFD is always in the horizontal position or does not change orientation achieving the desired output force is easy. However, if the AFD changes orientation the pressure must be varied along the robot path.

Two system variables have to be considered when achieving a desired output force: the Weight carried by the AFD, and the angle of the Carriage with respect to gravity. The angle of the Carriage must be known so that the Weight can be compensated for. The Weight is the sum of the process equipment and the AFD Carriage itself. This value can be back calculated from the area and pressure in the pneumatic actuator. The best method to determine the Weight is with a calibrated load cell. The angle of the Carriage to the gravity vector is defined as shown below in Figure 12.

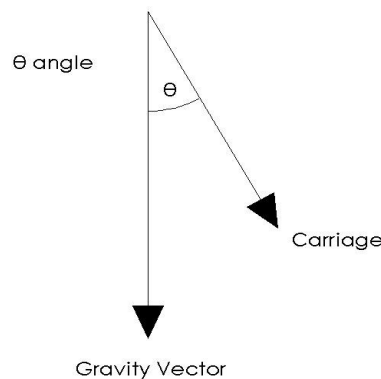

Figure 12: Definition of the carriage angle.

The *AFD82* is available in two configurations, the *AFD81*, and the *AFD82*. The *AFD81* has a pair of single-acting pneumatic actuators, so it may only apply positive forces. The *AFD82* has two pairs of single-acting actuators acting in opposite directions. This allows the *AFD82* to apply both positive and negative forces. The area of the pair of cylinders is 1.4 in<sup>2</sup> (904.7 mm<sup>2</sup>) so, for every 1.0 psi (0.07 bar) of supply pressure the *AFD* applies 1.4 lbs (89 N/Bar) of force. This makes the *AFD82* very easy to setup. To apply a 20 lbs. (89 N) force just set the supply pressure to 14.3 psi (1 Bar). This, however, does require the user to supply one (the *AFD82* requires two) precision pressure regulator to accurately adjust the applied force. The pressure regulator may be either manually or electrically controlled proportional pressure regulators. The force output repeatability and resolution is directly related to the quality of the pneumatic regulator.

The following are equations defining the applied force from each of the *AFD82*.

*AFD81* (Single Acting) Applied Force:

$$F_a = (1.4 \times P_s) + (W + 9.0) \cos(\theta) \quad \text{English units}$$

$$F_{am} = (89 \times P_s) + 9.81 \times (W + 4.1) \cos(\theta) \quad \text{Metric units}$$

Where:

$$F_a = \text{Net AFD applied force (lbs.)}$$

$$F_{am} = \text{Net AFD applied force (N)}$$

$$P_s = \text{Supply pressure (psi or bar)}$$

$$W = \text{Weight (lbs. or kg)}$$

$$\theta = \text{Carriage angle relative to gravity (See Figure 12)}$$

*AFD82* (Double Acting) Applied Force:

$$F_a = F_p - F_n + (W + 9.0) \times \cos(\theta) \quad \text{English units}$$

$$F_{am} = F_{pm} - F_{nm} + 9.81 \times (W + 4.1) \cos(\theta) \quad \text{Metric units}$$

Where:

$$F_a = \text{Net AFD applied force (lbs.)}$$

$$F_{am} = \text{Net AFD applied force (N)}$$

$$F_p = \text{Force in positive direction} = (1.4 \times P_{sp})(\text{lbs.})$$

$$F_n = \text{Force in negative direction} = (1.4 \times P_{sn})(\text{lbs.})$$

$$F_{pm} = \text{Force in positive direction} = (89 \times P_{sp})(N)$$

$$F_{nm} = \text{Force in negative direction} = (89 \times P_{sn})(N)$$

$$P_{sp} = \text{Positive side supply pressure (psi or bar)}$$

$$P_{sn} = \text{Negative side supply pressure (psi or bar)}$$

$$W = \text{Weight (lbs. or kg)}$$

$$\theta = \text{Carriage angle relative to gravity (See Figure 12)}$$

## 7.0 Technical Specifications

Maximum Applied Force: 115 lbs. (512 N)  
 Maximum Payload: 115 lbs. (52 kg)  
 Weight: AFD80-1 34 lbs. (15 kg)  
           AFD80-2 24 lbs. (11 kg)  
           AFD80-3 24 lbs. (11 kg)  
 Force Scale Factor: 1.4 lbs/psi (89 N/bar)  
 Compliant Stroke: 1.6 in. (40 mm)  
 Temperature: 50° to 122° F (10° to 50° C)  
 Humidity: 5% to 95%, Non-Condensing  
 Supply air: Non-lubricated, Dry, 5µm Filtered, 80 psi (5.5 bar) Max.

*Specifications subject to change without notice.*

Fastener Tightening Torque Specs					
Fastener Size	Torque			Minimum Depth	
	in.-lbs.	ft.-lbs.	N·m	in.	mm
M4 x .7	50	4.2	5.6	0.17	4.3
M5 x .8	85	7.1	9.6	0.21	5.3
M6 x 1	140	11.7	15.8	0.25	6.3
M8 x 1.25	348	29.0	39.3	0.33	8.4
M10 x 1.5	600	50.0	67.8	0.41	10.5

## 8.0 Preventative Maintenance Schedule

It is highly recommended to adhere to the preventative maintenance schedule in order help extend the longevity of the specified PushCorp, Inc. equipment. Failing to do so could cause a loss in functionality as well as a decrease in product life.

<b>PUSHCORP AFD</b>				
<b>Maintenance</b>	<b>Weekly</b>	<b>Monthly</b>	<b>3 Months</b>	<b>6 Months</b>
Remove debris from AFD	X			
Check that the connectors are not bent/damaged	X			
Check to see if the carriage moves back and forth easily	X			
Measure the supply and purge lines at the tool for recommended pressure/flow and ensure no losses in the pneumatic supply		X		
Check filters for contamination – replace if dark yellow/brown		X		
Replace filter cartridge(s)				X

Agency/Organization: \_\_\_\_\_

Date Completed: \_\_\_\_\_