

INSTALLATION INSTRUCTIONS

WOOD PILASTER

TOOLS REQUIRED:

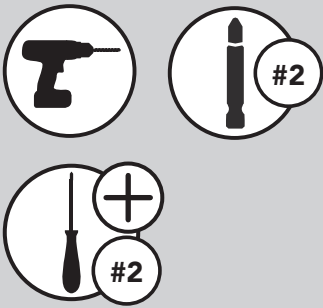

ESTIMATED ASSEMBLY TIME:

25 MIN

NOT INCLUDED:

- Pilaster Upright Mounting Screws
- Drawer Slides
- Drawer Boxes

CARE AND MAINTENANCE:

Clean with a damp cloth and wipe parts dry.

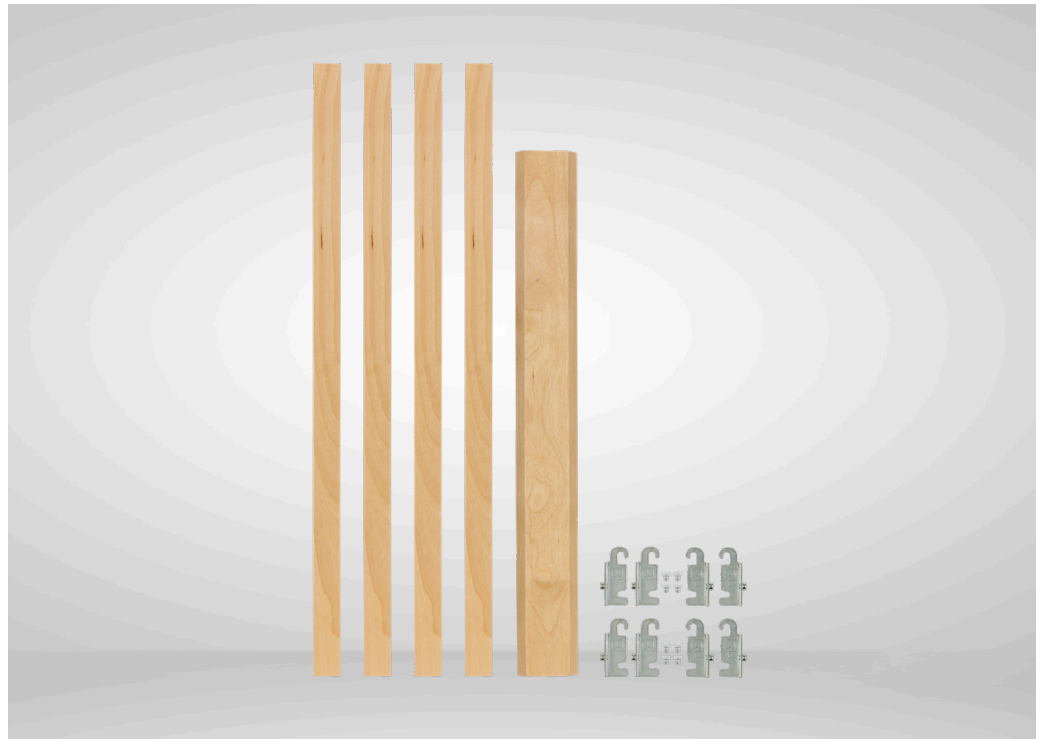

Parts List		
No.	Description	Qty
A	Pilaster Upright	4-8
B	Slide Bracket Sets	2-5
C	Installation Template	1

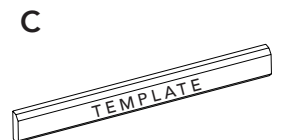
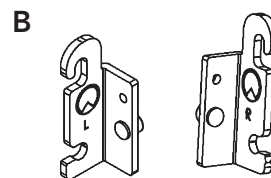
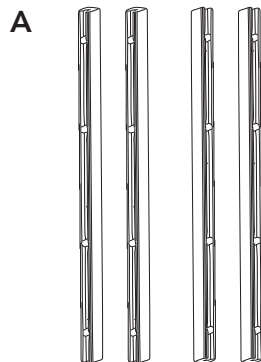

For video instruction visit:
rev-a-shelf.com/videos

STEP 1

Place the Installation Template (**Part C**) vertically behind the face frame of the cabinet. Place the Pilaster Upright (**Part A**) against the back of the Installation Template. Attach each Pilaster Upright to cabinet using (4) wood screws (not included). In frameless cabinets, place the template 3/4" back from the front edge of the cabinet.

NOTE:
Pilaster Uprights can be installed with metal pins facing toward the front or the rear of the cabinet.

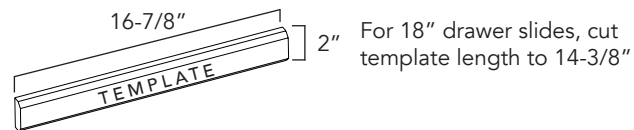
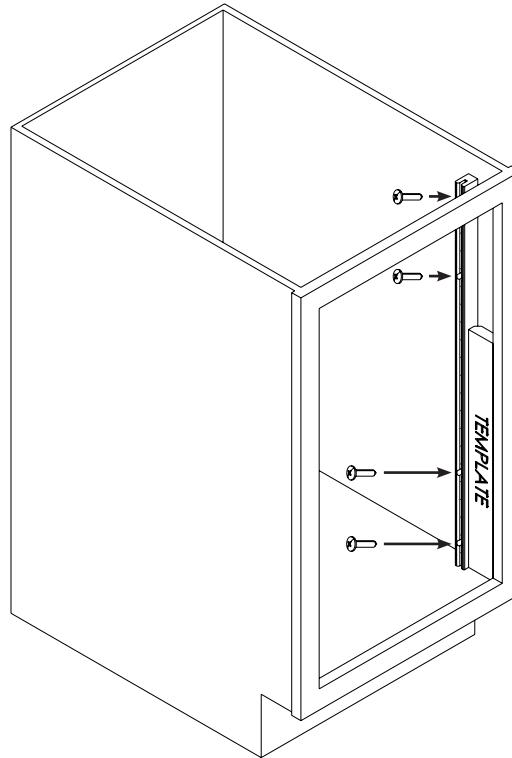
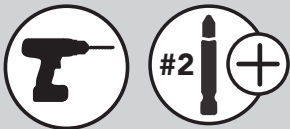

STEP 2A

Lay the Installation Template on its side on the bottom of the cabinet, against the back of the front Pilaster Upright. Place the rear Pilaster Upright against the back of the Installation Template, and attach using one screw in the bottom location.

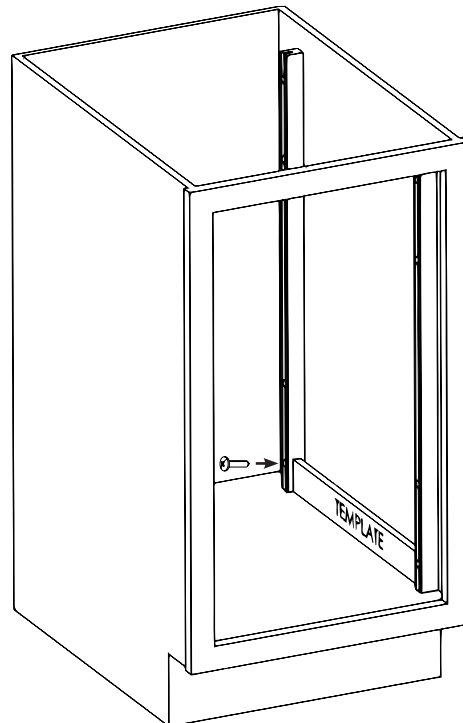
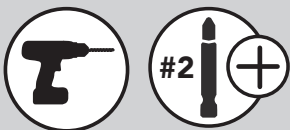

STEP 2B

Move the Installation Template to the top of the Pilaster Uprights, and attach to cabinet wall using an additional (3) screws.

Repeat steps 1-2 on other side of cabinet to install remaining Pilaster Uprights. For tall pantry kits, stack additional Pilaster Uprights vertically on top of Pilaster Uprights previously installed in steps 1 and 2.

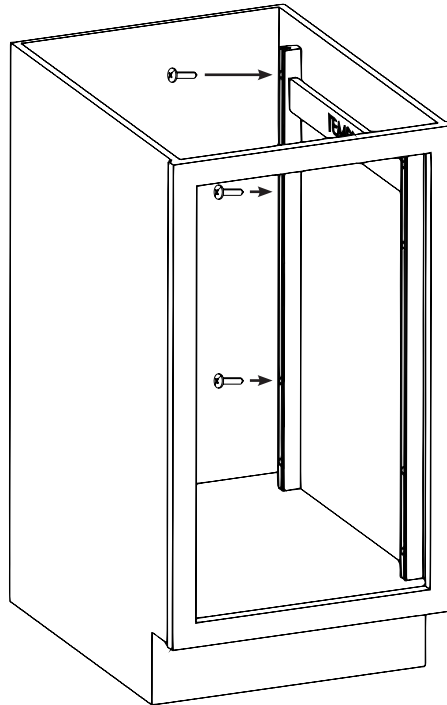
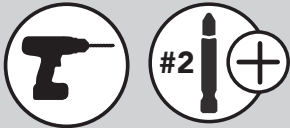

STEP 3

Install the left and right Slide Mounting Brackets (Part B) onto the slides in recommended mounting holes, using provided Slide Bracket screws. Rev-A-Shelf Logo on Slide Bracket should face the front of the slide (See Figure 1).



FIG. 1

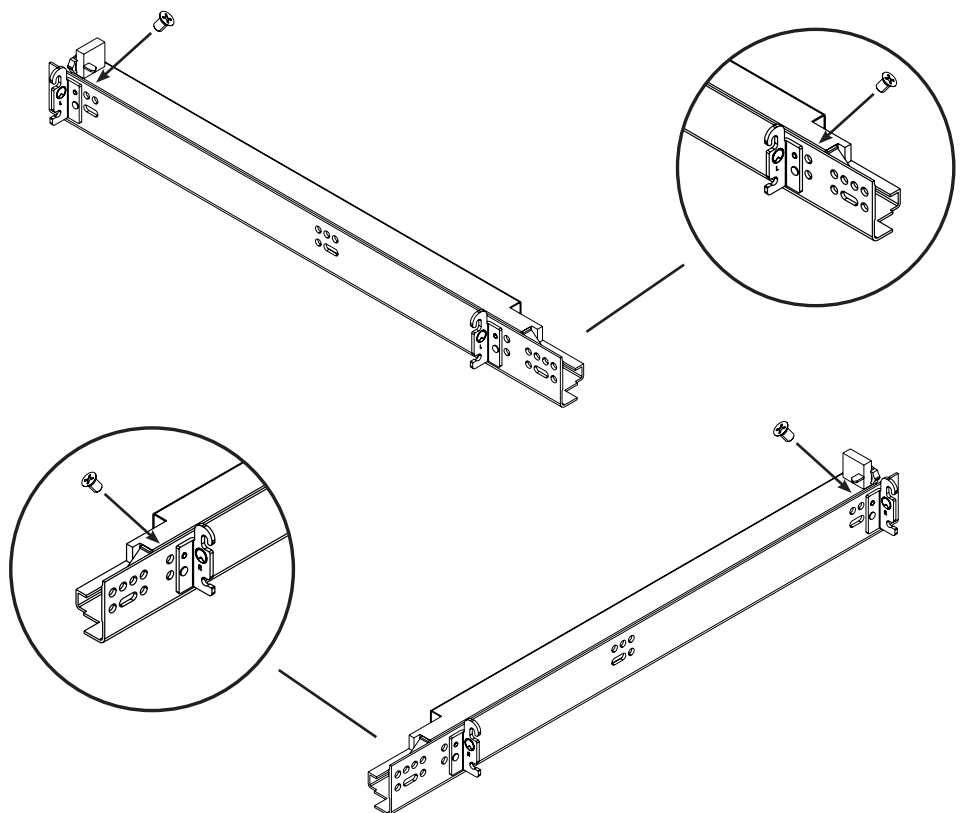

CALCULATING DRAWER BOX SIZE

[Use this sheet if you have installed the Pilaster Rails (Part A) into the cabinet, and need to build a drawer box]

To calculate Inside Drawer Width* deduct 54 mm (2-1/8") from width "W", between the wood Pilaster rails.

*Using 15/32" - 5/8" Drawer Side Material

**For thinner or thicker drawer side material, refer to slide manufacturer drawer box construction recommendations. Slide brackets add 1/2" to overall width between pilasters.

OR

To calculate Outside Drawer Width, use Table A

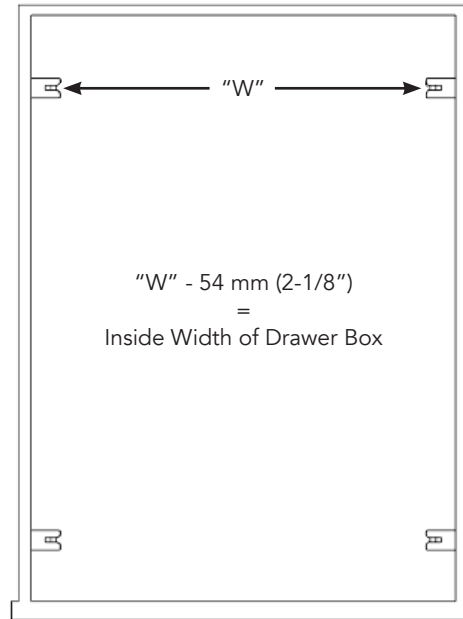

TABLE A

Drawer Side Thickness	16 mm (5/8")	15 mm (19/32")	14 mm (9/16")	13 mm (1/2")	12 mm (15/32")
Deduct from Inside Pilaster Width "W" to determine outside width of drawer box	23 mm (29/32")	25 mm (31/32")	27 mm (1-1/16")	29 mm (1-5/32")	31 mm (1-7/32")

PILASTER UPRIGHT TRIM GUIDE

[Use this sheet if you need to trim the wood pilaster uprights]

- Minimum trim width of all Pilaster Rails is 7/8"
- Slide Bracket adds 1/4" width per side
- A and B minimum is 1-1/8" each side (7/8" Pilaster Upright + 1/4" slide bracket)
- A and B dimensions can be different to allow for hinge clearance

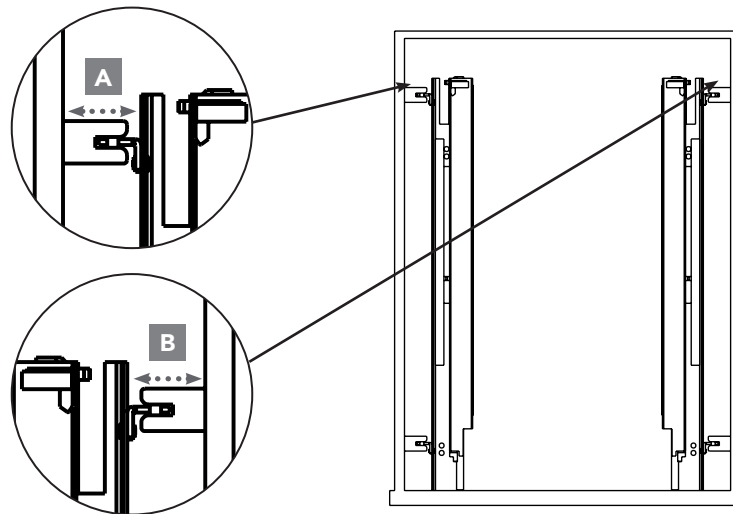

*Note - Top-down view of cabinet



12400 Earl Jones Way
 Louisville, KY 40299
 rev-a-shelf.com
 Customer Service: 800-626-1126