

Thank you for choosing this quality product. Be sure to check all packaging materials carefully for small parts that may have loosened inside the carton during shipment and place on a non-abrasive surface.

### IMPORTANT

These parts can be cumbersome and heavy to some people, therefore, the assistance of two or more people are recommended in order to prevent personal injury and ensure the furniture is not damaged during the assembly Process.

### CARE INSTRUCTIONS

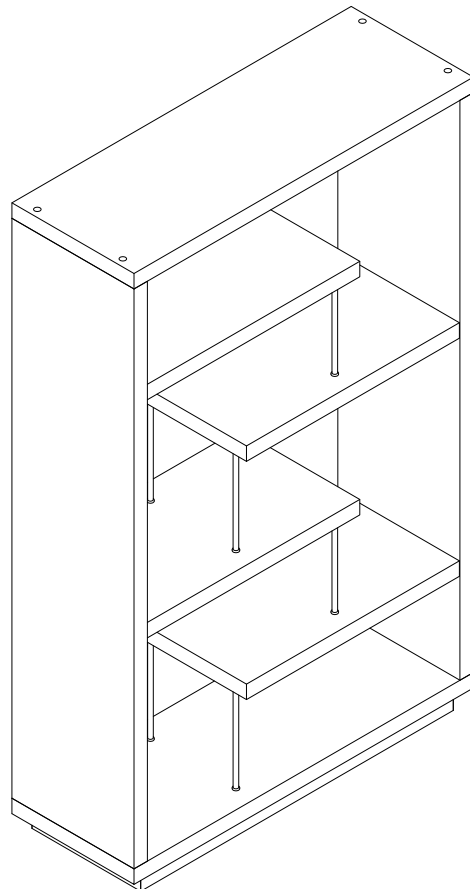
1. Dust often using a clean, soft, dry and lint-free cloth.
2. Blot spills immediately and wipe with a clean, damp, cloth.
3. We do not recommend the use of chemical cleansers, abrasives

### IMPORTANT SAFETY INSTRUCTIONS






1. Please read all instructions carefully before assembling.
2. Keep instructions for future use.
3. Use only vendor supplied hardware to assemble. Using unauthorized hardware could jeopardize the structural integrity of the item.

### PART LIST

- A. [1] TOP FRAME
- B. [2] SIDE FRAME
- C. [1] TOP SHELF
- D. [3] BOTTOM SHELF
- E. [1] BOTTOM FRAME
- F. [8] POST



### HARDWARE LIST

| NO | DESCRIPTION   | QTY |
|----|---|-----|
| 1  |  ALLEN HEAD BOLT M8 X 60MM | 08  |
| 2  |  ALLEN HEAD BOLT M8 X 50MM | 08  |
| 3  |  LOCK WASHER               | 16  |
| 4  |  PLAIN WASHER              | 16  |
| 5  |  ALLEN WRENCH              | 01  |

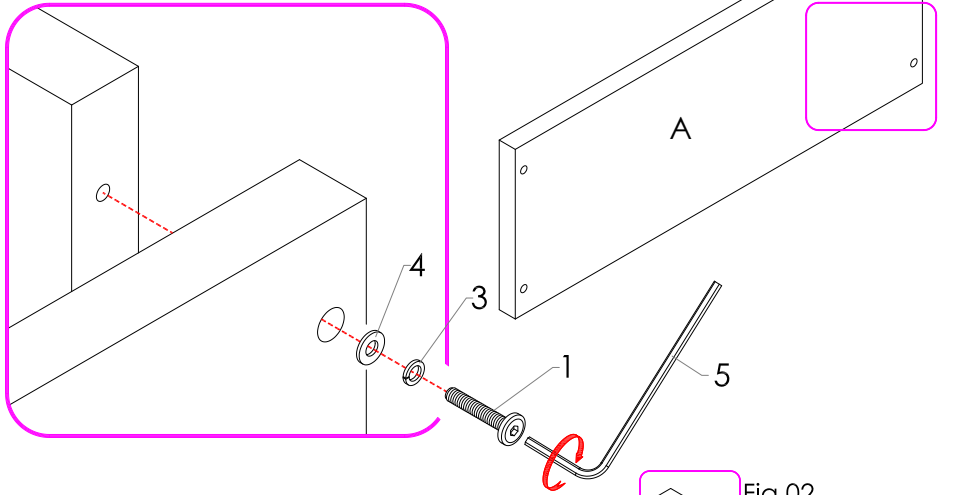
## INSTRUCTIONS:

1. Lay the Top frame (A) and Side frame (B) on a flat surface.

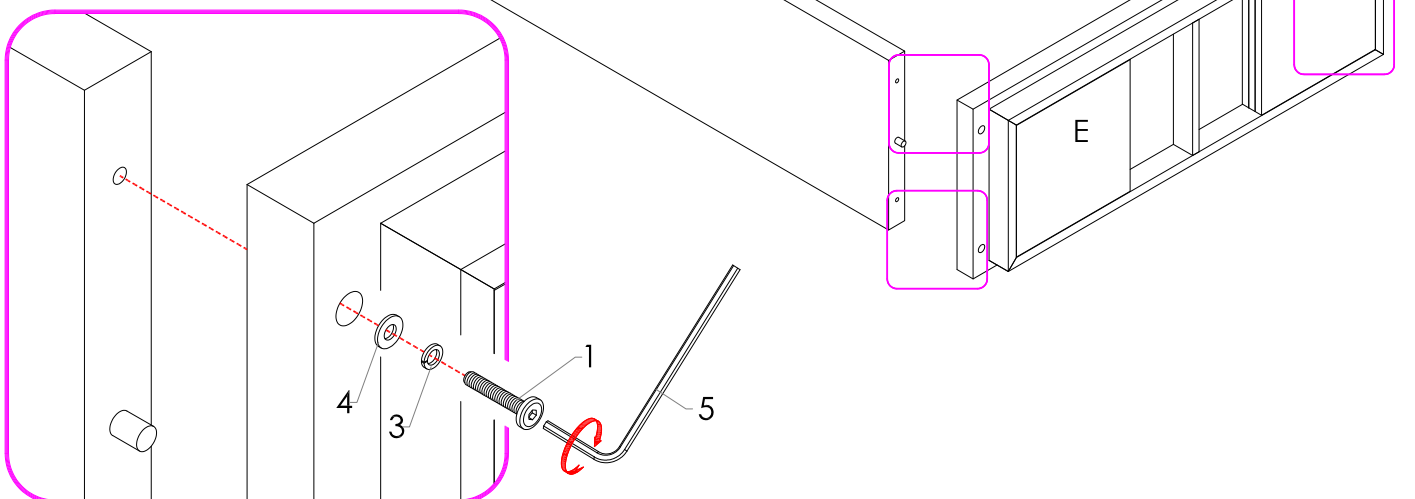
2. Attach the Top frame (A) to the Side frame (B). Align and insert Allen bolt (1), lock washer (3), flat washer (4). Tighten all the bolts by using Allen wrench (5). See **FIGURE 01**.

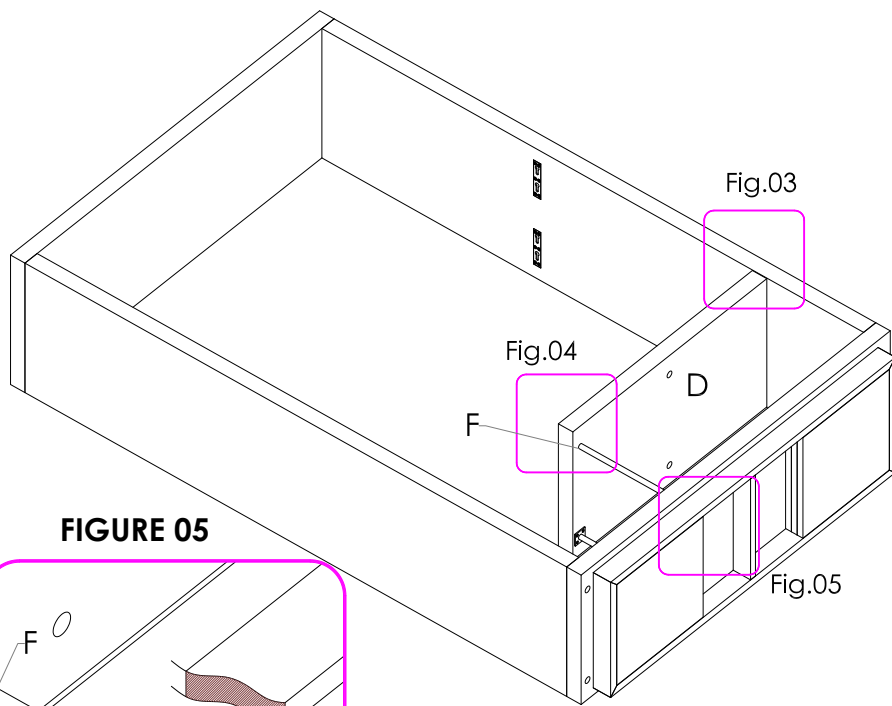
3. Repeat the above procedure with the other side frame (B) to attach it to the Top frame (A), and then repeat to connect side frame to the Bottom frame (E) . See **FIGURE 01**.

**FIGURE 01**



**FIGURE 02**

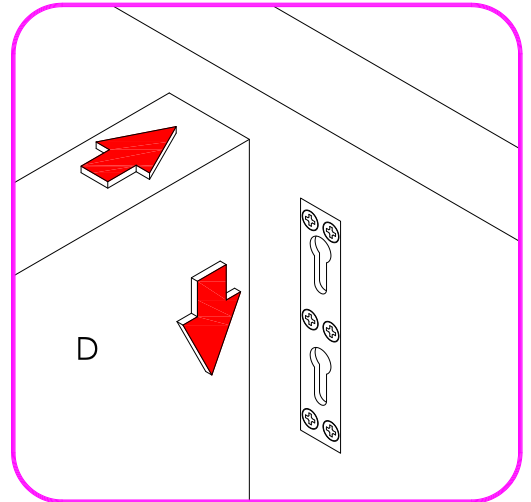




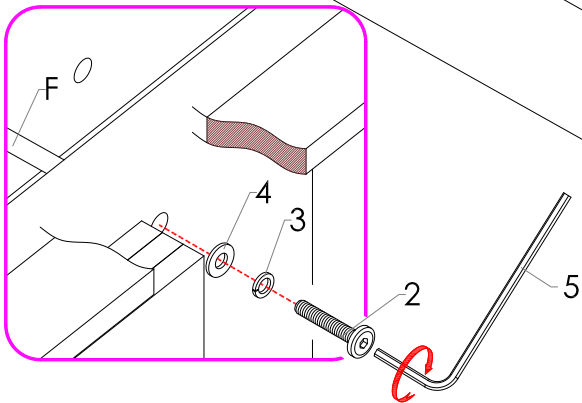
4. Install the Bottom shelf (D) to the side frame - right. See **FIGURE 03**. Then, align and insert the threaded rod of the the Posts (F) into the fixed nuts at the underneath of the shelf, next turn the posts clockwise to tighten. See **FIGURE 04**.

5. Install the end of the posts to the bottom frame. Align and insert Allen bolt (2) together with lock washer (3) and Flat washer (4). Tighten the bolt by using Allen wrench (5). See **FIGURE 05**.

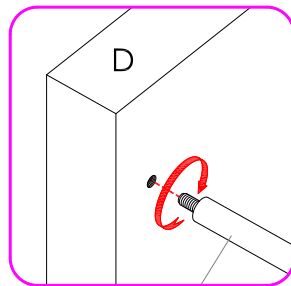
**FIGURE 03**



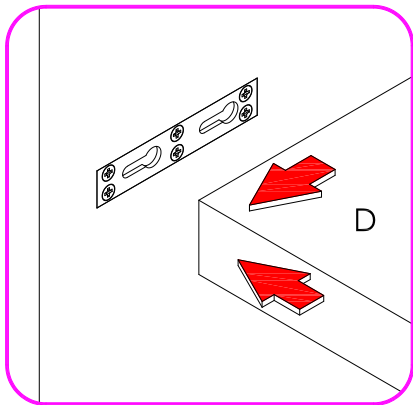
**FIGURE 05**



**FIGURE 04**



**FIGURE 06**

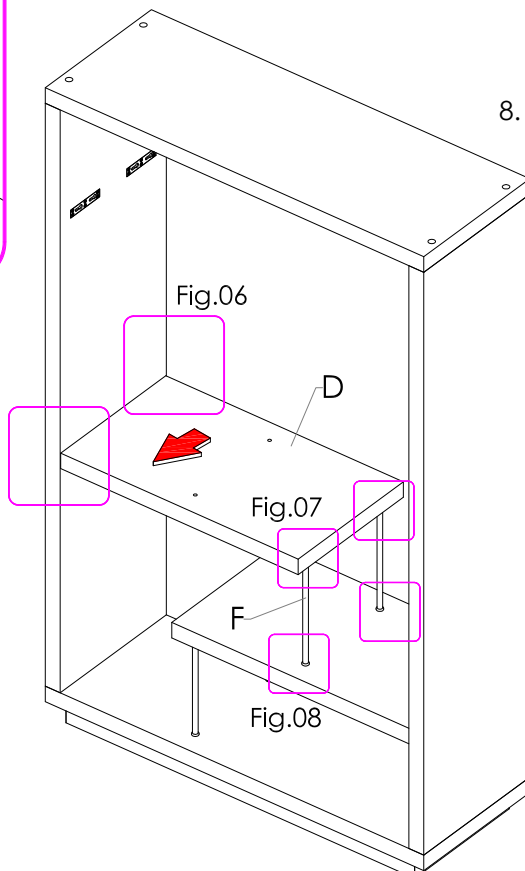
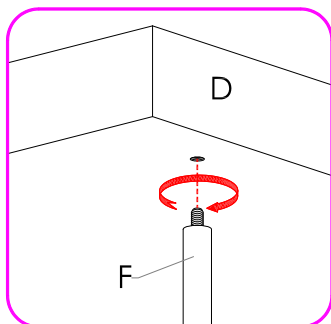


6. Lay the assembled furniture upright.

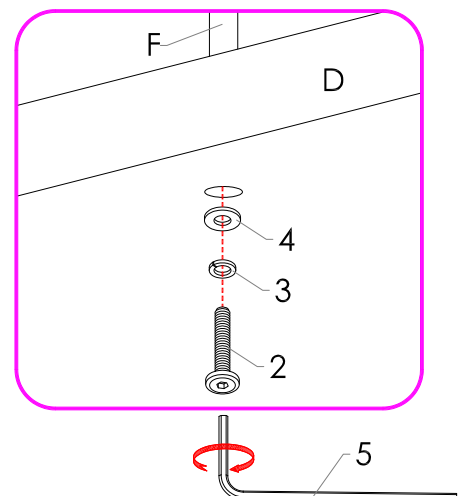
7. Install another bottom shelf (D) to the Side frame - Left (See **FIGURE 06**). Then, align and insert the threaded rod of the the Posts (F) into the fixed nuts at the underneath of the shelf, next turn the posts clockwise to tighten. See **FIGURE 07**.

8. Install the end of the posts to the bottom shelf. Align and insert Allen bolt (2) together with lock washer (3) and Flat washer (4). Tighten the bolt by using Allen wrench (5). See **FIGURE 08**.

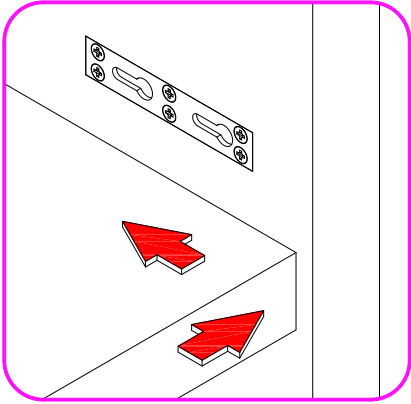
**FIGURE 07**



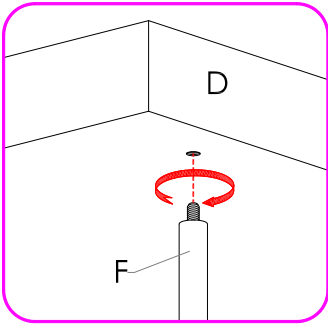
**FIGURE 08**



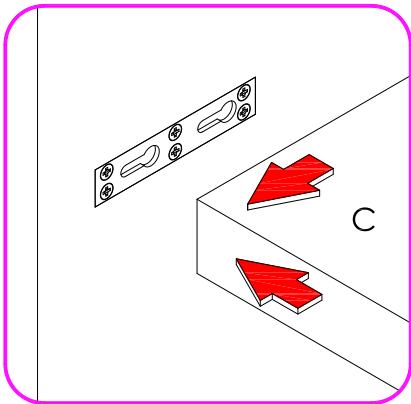
**FIGURE 09**



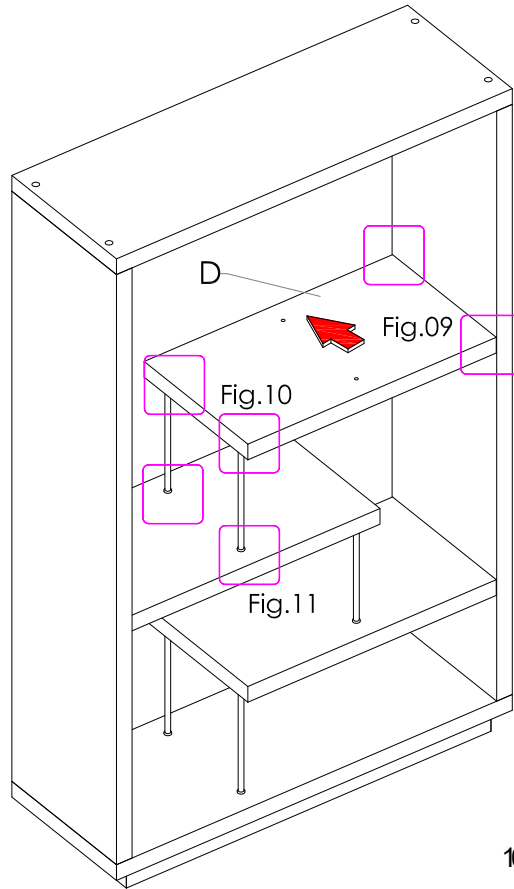
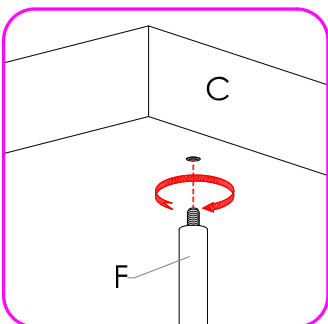
**FIGURE 10**



**FIGURE 12**

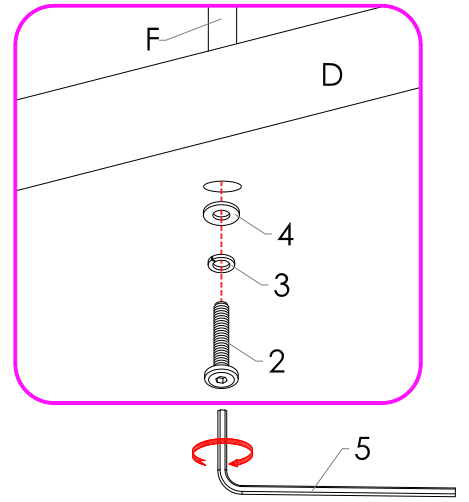


**FIGURE 13**



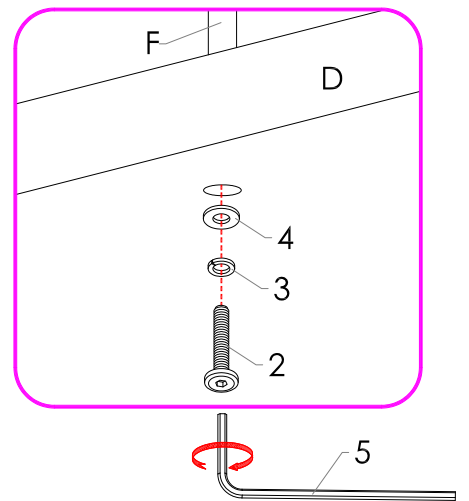
9. The same as Step #7 - #8. Repeat similar with another Bottom shelf (D) . See **FIGURE 09, 10, 11.**

**FIGURE 11**



10. The same as Step #7 - #8. Repeat similar with Top shelf (C) . See **FIGURE 12, 13, 14.**






**FIGURE 14**



## FURNITURE TIPPING RESTRAINT INSTRUCTIONS

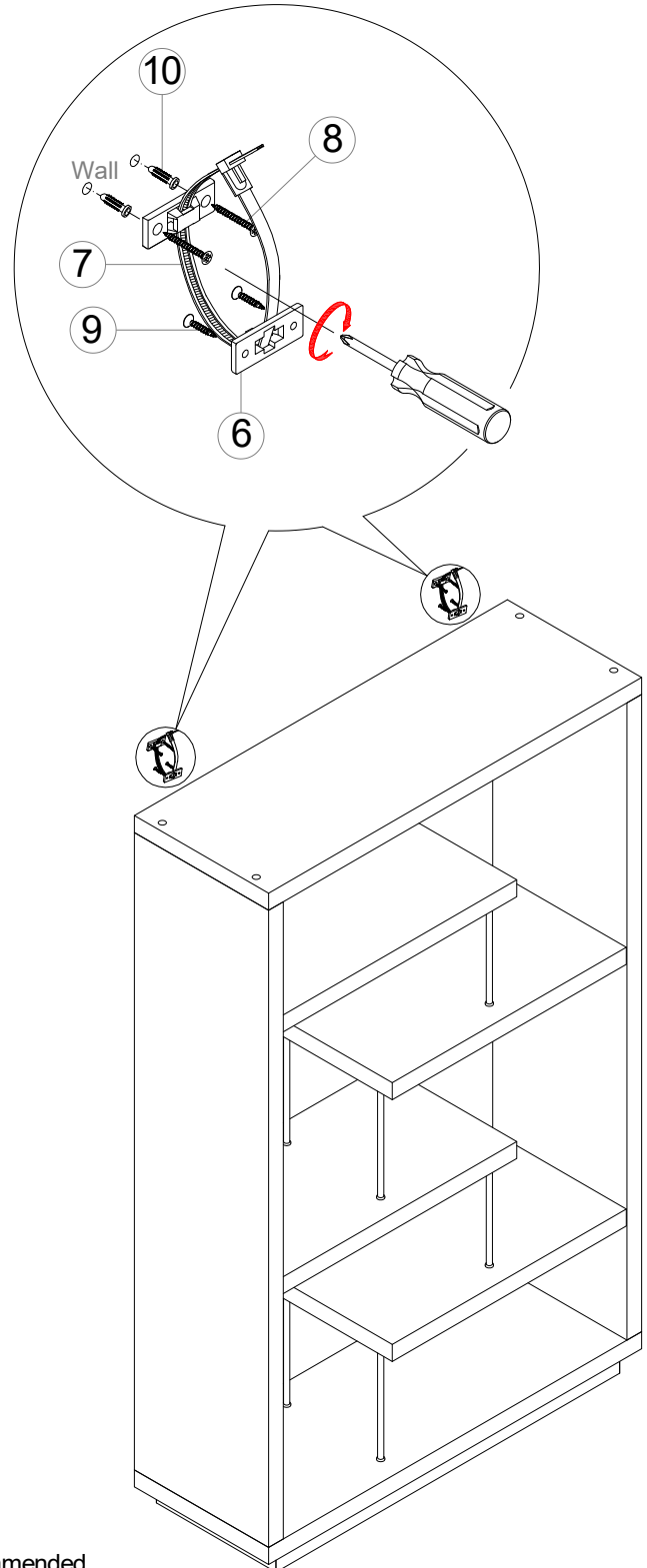
Young children may be injured by tipping furniture and the use of a tipping restraint is highly recommended. When properly installed, this restraint could provide protection against the unexpected tipping of furniture due to small tremors, bumps or climbing. We recommend mounting this restraint to a wall stud.

**WARNING:** This product is only a deterrent. It is not a substitute for proper adult supervision.

| NO | DESCRIPTION   | QTY |
|----|---|-----|
| 6  |  PLASTIC BRACKET           | 4   |
| 7  |  RESTRAINT STRAP           | 2   |
| 8  |  PHILLIPS SCREWS (M4 x 30) | 4   |
| 9  |  PHILLIPS SCREWS (M4 x 20) | 4   |
| 10 |  PLASTIC ANCHOR            | 4   |

## INSTALLATION INSTRUCTION

1. Attach two of the Plastic Brackets near the top back edge of the furniture piece by inserting the shorter screws.
2. Determine the final position of the furniture piece. Mark locations on the wall approximately 2" below the brackets mounted to the back of the furniture.
3. Drill a shorter hole into the wall stud. If wall stud is not available, drill a hole into the wall and insert Plastic Anchor. Gently tap the Anchor until the flange is flush with the wall.
4. Attach the second set of brackets by inserting the longer screw through the bracket and into the wall.
5. Carefully move the chest backward within 1.5" to 2" from the wall.
6. Place the furniture so that the brackets on the back edge are in line with the brackets in the wall.
7. Lace one end of the nylon restraint strap down through each bracket. Bring both ends together and slide the beaded end until it snap locks into the keyhole slot.
8. To double lock; return the beaded end back through the keyholes as shown.
9. Check to make sure the straps are securely laced and locked to the brackets.



## CARE INSTRUCTIONS

1. Dust often using a clean, soft, dry and lint-free cloth.
2. Blot spills immediately and wipe with a clean, damp, cloth.
3. We do not recommend the use of chemical cleansers, abrasives or furniture polish on our lacquered finish.

## IMPORTANT SAFETY INSTRUCTIONS

1. Please read all instructions carefully before assembling.
2. For your safety, assembly by two or more adults is strongly recommended.
3. Keep instructions for future use.
4. Use only vendor supplied hardware to assemble. Using unauthorized hardware could jeopardize the structural integrity of the item.