

CUSTOMER DRAWING

This drawing is the property of Rev-A-Shelf (RAS) and is disclosed in confidence to the extent its subject matter is original to RAS. Any vendor receiving this drawing from RAS shall hold and use this drawing for the sole benefit of RAS and shall not disclose it to, or use or reproduce it for any third party, or perform any act adverse to the interest of RAS with respect to this drawing without the express written permission of RAS. Vendors shall not revise any physical, dimensional or performance characteristic unless authorized by Rev-A-Shelf Engineering.

REV.	DATE	BY	DESCRIPTION OF CHANGE

INCH [MM]	AMERICAN PROJECTION 	BY	DATE	REV-A-SHELF, INC.	
		DRAWN	LCS 6-02-22		
TOLERANCES		MATERIAL	DRAWING NO.		SCALE
MAT.	DEC.		4WCTM-15DM2-162		
(WOOD)	.XX ±.03 [.8mm]	FINISH	PART NO.		SHEET OF
(OTHER)	.XX ±.02 [.5mm]		4WCTM-15DM2-162		
(ALL)	.XXX ±.005 [.13 mm]	FRACTIONS ±1/32 [.8 mm]		1 2	

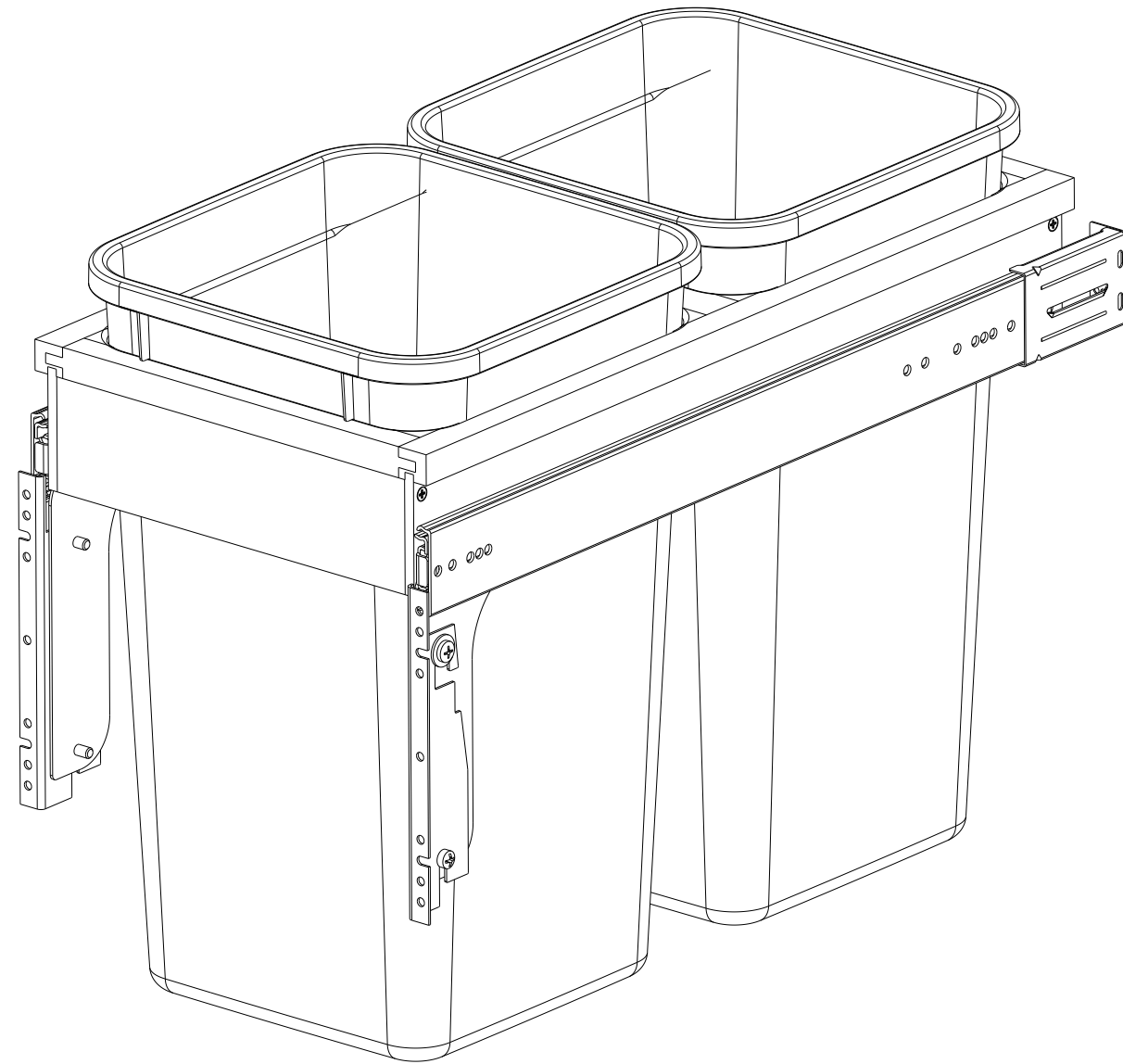

PART DIMENSIONS		
	MIN	MAX
WIDTH	11.75	
DEPTH	23.25	24.50
HEIGHT	17.75	
CONTAINER CAPACITY	27 X 2	
CONTAINER UOM	QT	

MIN CABINET OPENING	
WIDTH	11.75
DEPTH	23.25
HEIGHT	18.25

SLIDE SPECIFICATIONS				
SLIDE TYPE	BALL BEARING	SLIDE EXTENSION	1-1/2" O.T.	MAX WEIGHT RATING
SLIDE CLOSING	NORMAL	SLIDE LENGTH	560 MM	
SLIDE MOUNTING	SIDE	SLIDE FINISH	ZINC	
				150 LB

CUSTOMER DRAWING

This drawing is the property of Rev-A-Shelf (RAS) and is disclosed in confidence to the extent its subject matter is original to RAS. Any vendor receiving this drawing from RAS shall hold and use this drawing for the sole benefit of RAS and shall not disclose it to, or use or reproduce it for any third party, or perform any act adverse to the interest of RAS with respect to this drawing without the express written permission of RAS. Vendors shall not revise any physical, dimensional or performance characteristic unless authorized by Rev-A-Shelf Engineering.

REV.	DATE	BY	DESCRIPTION OF CHANGE

INCH [MM]	AMERICAN PROJECTION	DRAWN	BY	DATE	REV-A-SHELF, INC.
			LCS	6-02-22	
			MATERIAL	DRAWING NO.	SCALE
			FINISH	4WCTM-15DM2-162	0.250
				PART NO.	SHEET OF
				4WCTM-15DM2-162	2 OF 2

TOLERANCES
 MAT. DEC.
 (WOOD) .XX ±.03 [.8mm]
 (OTHER) .XX ±.02 [.5mm]
 (ALL) .XXX ±.005 [.13 mm]
 FRACTIONS ±1/32 [.8 mm]

ANGLES
 ±1/2°