

19.49
[495]

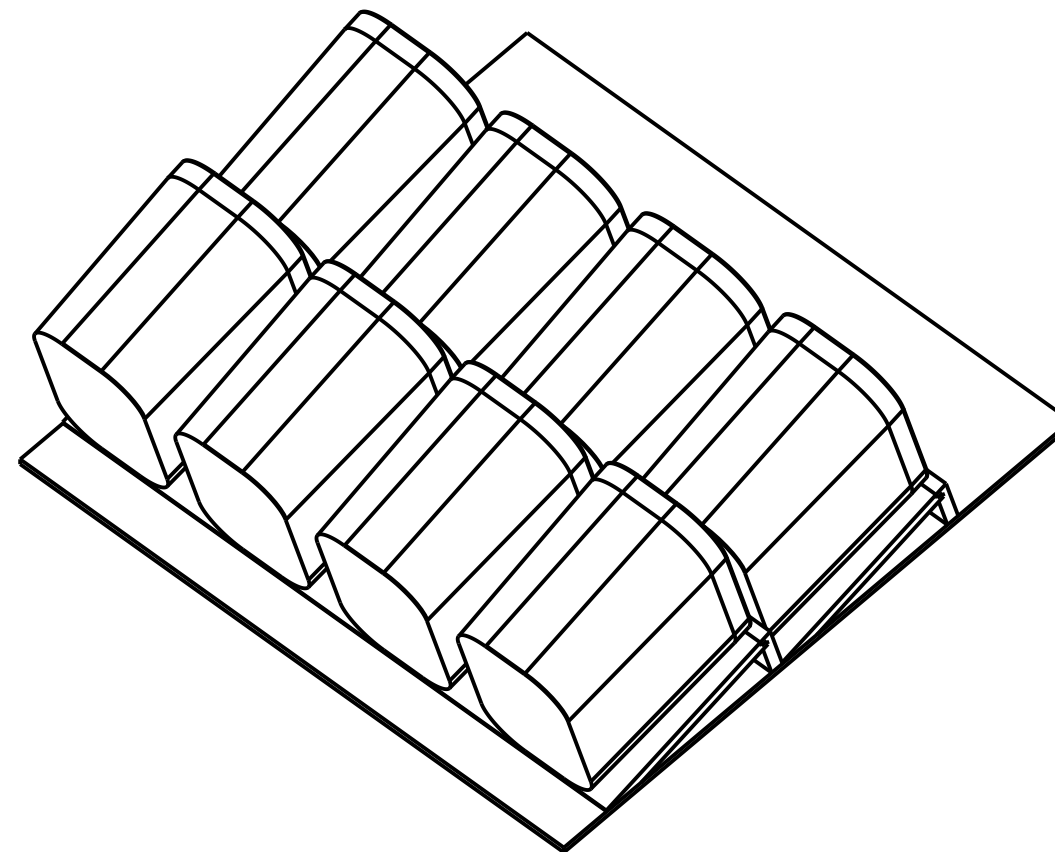
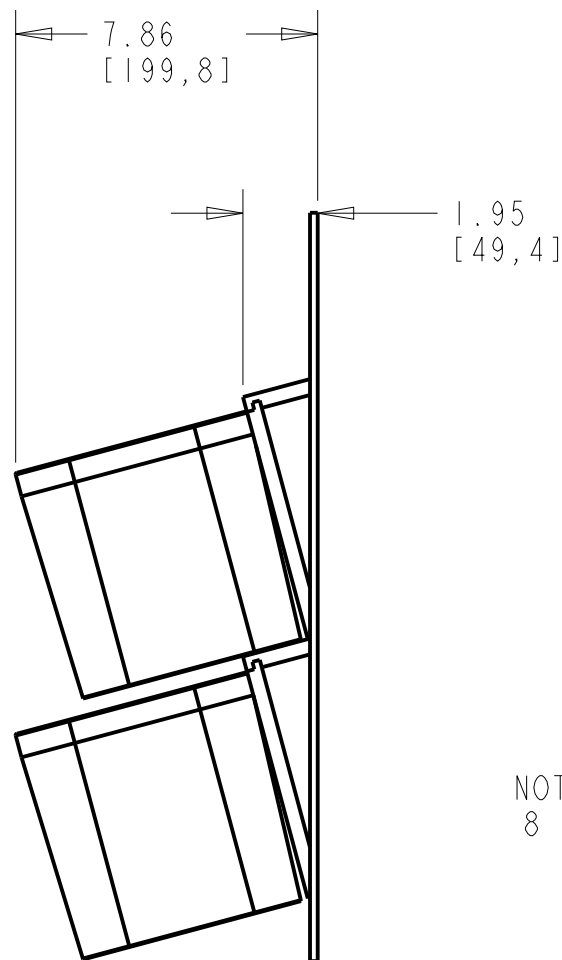

NOTE: TRIM ALLOWANCE WIDTH IS BASED OFF 8 OXO CONTAINERS

NOTE: 40X0-24-1 COMES WITH 8 X 1.7 QT OXO CONTAINERS

TRIMMABLE PART DIMENSIONS		
	MIN	MAX
WIDTH	17.19/432	19.25/489
DEPTH	15.16/385	19.49/495
HEIGHT	7.86/200	7.86/200
DRAWER COMPATIBILITY		
MIN HEIGHT 8.00/203		

CUSTOMER DRAWING

This drawing is the property of Rev-A-Shelf (RAS) and is disclosed in confidence to the extent its subject matter is original to RAS. Any vendor receiving this drawing from RAS shall hold and use this drawing for the sole benefit of RAS and shall not disclose it to, or use or reproduce it for any third party, or perform any act adverse to the interest of RAS with respect to this drawing without the express written permission of RAS. Vendors shall not revise any physical, dimensional or performance characteristic unless authorized by Rev-A-Shelf Engineering.

REV.	DATE	BY	DESCRIPTION OF CHANGE

INCH [MM]	AMERICAN PROJECTION	DRAWN	BY	DATE	REV-A-SHELF, INC.
		JAB	JAB	10/16/23	
TOLERANCES					SIZE
MAT.	DEC.	ANGLES	MATERIAL	DRAWING NO.	OXO CONTAINER
(WOOD) .XX ±.03 [8mm]		±1/2°		40X0-24-1	DRAWER INSERT B24
(OTHER) .XX ±.02 [5mm]			FINISH	PART NO.	SCALE
(ALL) .XXX ±.005 [13 mm]				40X0-24-1	0.200
FRACTIONS ±1/32 [8 mm]					SHEET OF
					1 1