

AFD1100

Adjustable Force Device Manual



PUSHCORP, INC.

Dallas, Texas

CAUTION

**Active Force Devices contain
calibrated electronics.**

HANDLE WITH CARE DO NOT DROP

DO NOT USE LUBRICATED AIR.

This device requires a dry, non-lubricated 80 to 90 psi (5.5 – 6.2 bar) air supply filtered to 5 μ m and a 0.3 micron oil mist separator.

Non-compliance with these requirements will void the manufacturer's warranty.

(See Section 4.3)

**All fasteners, mounting holes and pipe threads on this tool are
METRIC.**

All *PushCorp, Inc.* electrical cables are rated for high twist and flex robotic applications with a minimum cable bending radius specification of 125mm (5 in). Cable damage resulting from failure to abide by this specification will not be covered under warranty.

Table of Contents

1.0 LIMITED WARRANTY.....	1
2.0 GENERAL OVERVIEW.....	3
3.0 QUICK START.....	3
4.0 INSTALLATION.....	4
4.1 Mounting Process Equipment.....	4
4.2 Mounting the <i>AFD1100</i>	5
4.2.1 Mounting the AFD1100-1 Vertical and AFD1100-2 Horizontal.....	5
4.2.2 Mounting the AFD1100-3 Table Top.....	5
4.3 Maximum Carriage Load Calculations.....	7
4.4 Pneumatic Connection.....	9
4.5 Internal Air Cartridge Filter.....	11
5.0 ADJUSTING CARRIAGE PRELOAD.....	11
6.0 TECHNICAL SPECIFICATIONS.....	13
7.0 PREVENTATIVE MAINTENANCE SCHEDULE.....	14

1.0 Limited Warranty

Duration:

One year from date of delivery to the original purchaser.

Who gives this warranty (warrantor):

PushCorp, Inc.

Telephone: (972) 840-0208

Corporate Address:

P. O. Box 181915

Dallas, Texas 75218

Shipping Address:

3001 W. Kingsley Rd.

Garland, Texas 75041

Who receives this warranty (purchaser):

The original purchaser (other than for purposes of resale) of the *PushCorp, Inc.* product

What products are covered by this warranty:

Any *PushCorp, Inc.* Adjustable Force Device or Adjustable Force Device accessory supplied or manufactured by the Warrantor.

What is covered under this warranty:

Defects in material and/or workmanship which occur within the duration of the warranty period.

What is NOT covered in this warranty:

- A. IMPLIED WARRANTIES, INCLUDING THOSE OF MERCHANTABILITY AND FITNESS FOR A PARTICULAR PURPOSE ARE LIMITED TO ONE YEAR FROM THE DATE OF ORIGINAL PURCHASE. Some states do not allow limitations on how long an implied warranty lasts, so the above limitations may not apply to you.
- B. ANY INCIDENTAL, INDIRECT, OR CONSEQUENTIAL LOSS, DAMAGE or EXPENSE THAT MAY RESULT FROM ANY DEFECT, FAILURE, MALFUNCTION OF THE *PUSHCORP, INC.* PRODUCT. Some states do not allow the exclusion or limitation of incidental or consequential damages so the above limitation or exclusion may not apply to you.
- C. Any failure that results from an accident, purchaser's abuse, neglect, unauthorized repair or failure to operate the products in accordance with the instructions provided in the owner's manual(s) supplied with the product.

Responsibilities of the Warrantor under this warranty:

Repair or replace, at Warrantor's option, products or components which have failed within the duration of the warranty period.

Responsibilities of the purchaser under this warranty:

- A. Deliver or ship the *PushCorp, Inc.* product or component to PushCorp, Inc. Service Center, Dallas, TX. Freight and insurance costs, if any, must be borne by the purchaser.
- B. Use reasonable care in the operation and maintenance of the product as described in the owner's manual(s).

When warrantor will perform repair or replacement under this warranty:

Repair or replacement will be scheduled and serviced according to the normal work flow at the service center, and depending on the availability of replacement parts. Purchasers requiring quicker repair may receive such with payment of a *PushCorp, Inc.* predetermined expediting fee.

This Limited Warranty gives you specific legal rights and you may also have other rights which vary from state to state.

2.0 General Overview

The *PushCorp, Inc. AFD1100* Adjustable Force Devices (US Patent No. 5,448,146) provide a superior force application system. The AFD can be placed in any position to enable a variety of manufacturing operations requiring a consistent applied force with 1.6 inches (40 mm) of compliant stroke. The AFD is designed to withstand continuous use in harsh industrial grinding, polishing, and drilling operations.

The *AFD1100* utilize a pneumatic actuator to provide the force and a load cell force sensor to provide closed-loop feedback to an *FCU1000* Active Compliance Controller. The *AFD1100* can apply up to a maximum 100 lbs. (445 N) of force. The AFD contains an accelerometer that monitors orientation and allows the unit to automatically compensate for gravitational and inertial effects. A linear potentiometer is also present within the AFD to sense the position of the Carriage.

Only two external connections are required to operate the *AFD1100*. First, dry, non-lubricated, filtered 80 - 90 psi (5.5 – 6.2 bar) supply air must be provided through flexible tubing. Second, the AFD must be connected to the *FCU1000* Controller with a *PushCorp* high flex multi-conductor cable. An optional Purge Port is provided for applications where excessive fine dust particles are created. This Purge Port connection provides additional airflow and internal positive pressure to minimize contamination entering the AFD. The Carriage has threaded mounting holes to provide easy process equipment attachment.

All these features combine to make the *PushCorp AFD1100* Adjustable Force Device a rugged, state-of-the-art technology capable of providing reliable, precise, and consistent results in a variety of industrial applications.

3.0 Quick Start

This section contains step-by-step instructions on how to quickly get the *AFD1100* Adjustable Force Device up and running for a quick test of its capabilities. Complete details on all the features are described in the sections that follow. It is recommended that the user read the entire manual before beginning any operations to fully understand all the aspects and features of the *AFD1100*.

- Step 1: Carefully unpack the *AFD1100* Force Device and the *FCU1000* Controller. Verify that all parts indicated on the packing list are present and in good condition. If there is a problem, please notify the factory immediately so that corrective action may be promptly initiated.
- Step 2: Securely attach the *AFD1100* Mounting Bracket to the manipulator mounting flange or support table per Section 4.2.
- Step 3: Connect a dry, non-lubricated, 5 μ m filtered 80 to 90 psi (5.5 to 6.2 bar) air supply to the force device per Section 4.3.
- Step 4: Consult the *FCU1000* Manual for electrical connections and software setup information.

Please read the following sections to learn the full potential and features of the *PushCorp AFD1100* Adjustable Force Device.

4.0 Installation

4.1 Mounting Process Equipment

The *AFD1100* Adjustable Force Device can accommodate many different types of process equipment. PushCorp provides a variety of standard process equipment such as weld shavers, high speed motors, plus other specialized tooling. Many end users also develop process equipment for their own applications. The AFD can be oriented parallel or perpendicular to the manipulator mounting flange, although it is important to note that the AFD can apply force only in the direction of Carriage translation.

When mounting process equipment to the Carriage extreme care should be taken while designing and installing the brackets. Correctly designed brackets will increase the stiffness of the Carriage by becoming an external superstructure for the Carriage. The Carriage can gain a tremendous amount of rigidity if this approach is executed correctly. Incorrectly designed brackets will deform the Carriage surface causing internal Linear Rail misalignment. A symptom of Carriage deformation is “slop” or “binding” of the Carriage. A deformed or loose Carriage will damage the Linear Rails and effect the consistency of your process. The Carriage preload is correctly set at the factory and should not require adjustment. If the Carriage becomes loose or binds after installing the process equipment, then the brackets must be removed and the problem corrected. *PushCorp, Inc.* can design and fabricate brackets to user supplied specifications as an option.

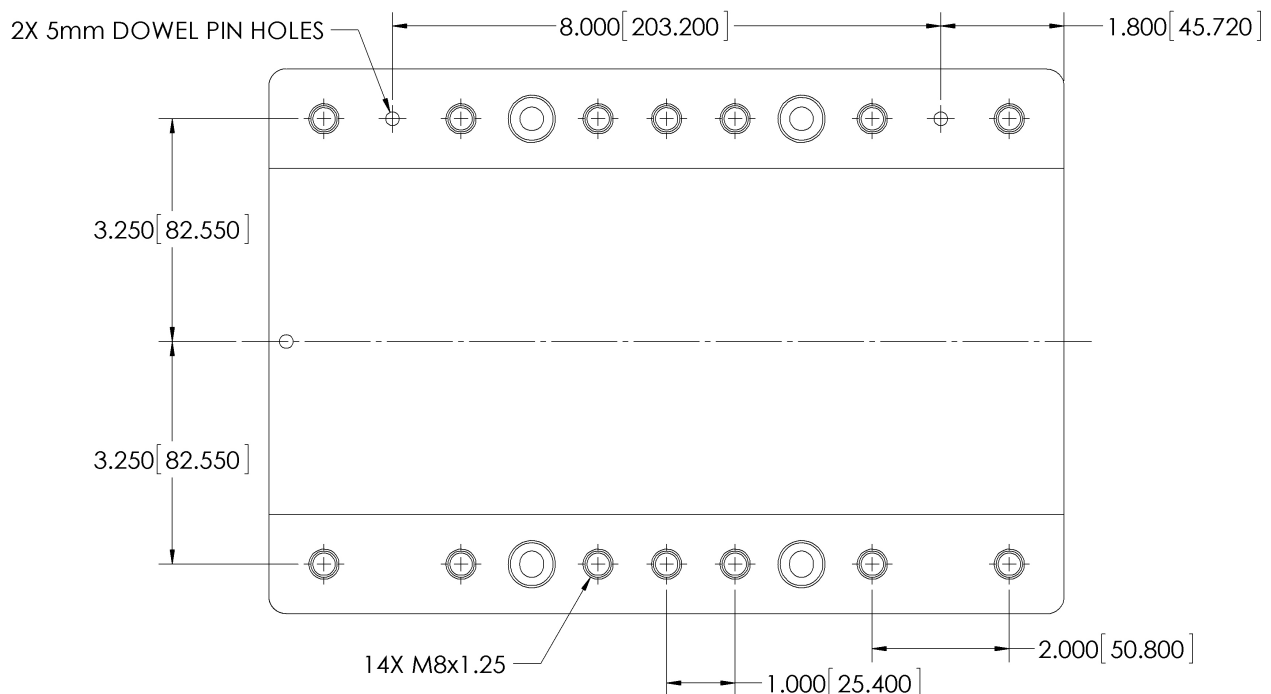

Figure 1. Carriage bolt hole pattern

The bolt pattern on the Carriage has been designed to facilitate motor installation in a number of configurations. The Carriage has (14) fourteen M8 x 1.25 mounting holes with a depth of 0.52 inch (13 mm) to provide secure attachment points. The mounting holes are spaced as shown in Figure 1. The Carriage also has (2) two 5mm dowel pin holes to facilitate alignment (See Figure 1 for location). These dowel pin holes are oversized to allow the pins to be glued into place using Loctite 609, or equivalent. **DO NOT press pins into the AFD Carriage, as this will damage the linear rails.**

Caution: The Fastener Tightening Torque Specs chart in Section 6.0 should be used to determine proper fastener length and torque for fasteners into the Carriage. This is to prevent pull-out of the Carriage helicoil inserts. Fasteners must not exceed a depth of 0.52 inches (13 mm) into the Carriage as this could damage the Linear Rails.

4.2 Mounting the AFD1100

The basic configuration of the *AFD1100* force device allows attachment to a stationary fixture or a robotic manipulator mounting flange. Specifying an *AFD1100-1*, *-2*, or *-3* determines which Mounting Bracket is supplied. Adapter plates or "quick-change" attachments can be used as well for mounting.

4.2.1 Mounting the AFD1100-1 Vertical and AFD1100-2 Horizontal

The *AFD1100-1* and *AFD1100-2* are supplied with a standard Mounting Bracket with a 90 mm three hole mounting pattern, See Figure 2. All three holes should be utilized to secure the Mounting Bracket to the robot mounting flange. If the Mounting Bracket is supplied blank or additional holes are required, it must first be removed from the device before drilling. Four cap screws are used to attach the Mounting Bracket to the *AFD1100*. Once the Mounting Bracket is removed, mounting holes may be placed anywhere within the crosshatched area shown in Figure 2. *PushCorp, Inc.* will supply engineering support to determine the mounting hole locations at no cost.

After drilling the required hole pattern, remove any burrs and clean any machining residue from the Mounting Bracket. The Mounting Bracket can then be reattached.

4.2.2 Mounting the AFD1100-3 Table Top

The *AFD1100-3* is designed for mounting on a stationary fixture. It has (4) four ≈ 0.33 " (≈ 8.4 mm) mounting holes spaced as shown in Figure 3. The *AFD1100-3* Table Top Mounting Bracket should not be modified without first consulting *PushCorp, Inc.*

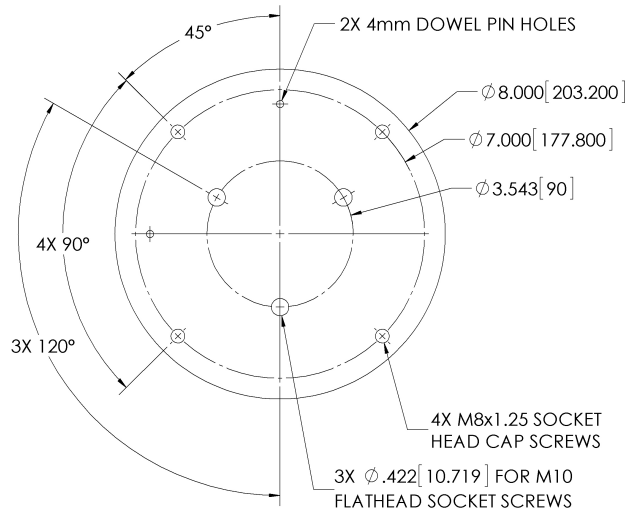

AFD1100-1

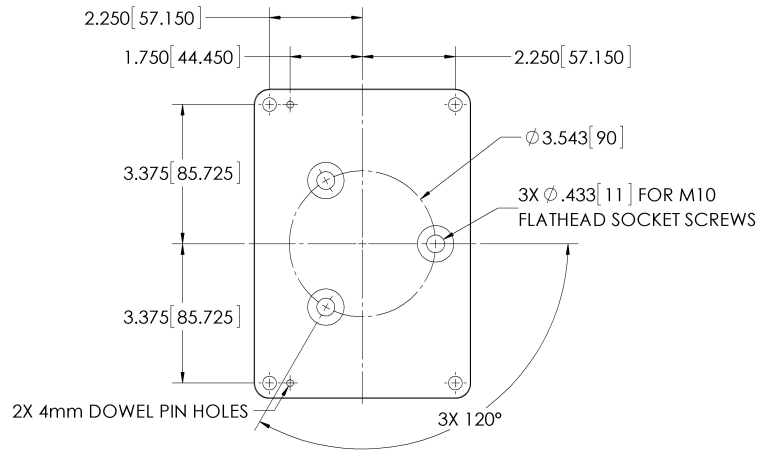

AFD1100-2

Figure 2. Mounting Bracket allowed hole locations.

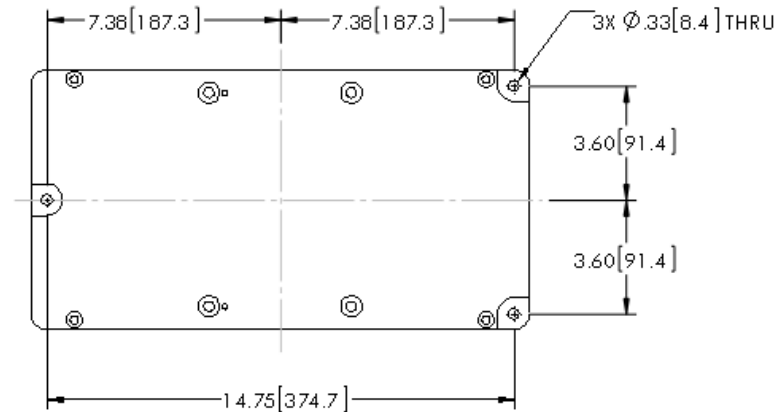

Figure 3. AFD1100-3 Mounting Bracket hole locations

4.3 Maximum Carriage Load Calculations

The Linear Rail bearings that support the *AFD1100* sliding Carriage have been selected to provide optimal performance with respect to capacity, size, and low friction. To ensure continued optimal performance it is very important not to overload these bearings. The following diagrams and associated equations are provided to check your application for excessive loading.

It is important to note that these equations require the use of Metric units. The necessary conversions are provided for your convenience. Insert your maximum applied force and process equipment weight (W) and overhang distances (D) to calculate an actual bearing load (L) that must be less than the maximum bearing load shown on the right side of the equation. The life of the bearings is 100,000 meters of linear motion, at the maximum allowable bearing load value. Exceeding this value (L) will reduce the life and operating at less than this value (L) will increase the life. It is common to have combined weight and force loads on the Carriage. These situations may require adding two or more of the scenarios shown below. If your tooling is not similar to any of the designs listed here, or if the information is not clear, please contact *PushCorp* Technical Support for assistance. Ball-bearing equations apply to the standard *AFD1100* tools. Roller-bearing equations apply to *AFD1100* tools ordered with the -HD, Heavy-Duty option.

W = Maximum Applied Force (N)

D = Load Overhang (mm)

L = Bearing Load (N)

⊕ = Concentrated Load Position

1 lbf. = 4.45 N

1 in. = 25.4 mm

1 N = 0.102 kg

Case 1

Standard Ball Bearings:

$$L = \frac{W \times (D + 248)}{616} < 150$$

Heavy-duty Roller Bearings:

$$L = \frac{W \times (D + 248)}{308} < 1300$$

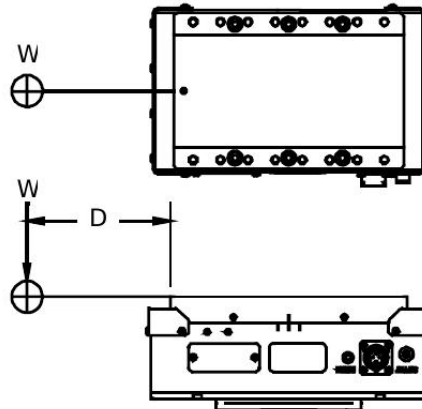

Case 2

Standard Ball Bearings:

$$L = \frac{W}{24} < 150$$

Heavy-duty Roller Bearings:

$$L = \frac{W}{12} < 1300$$

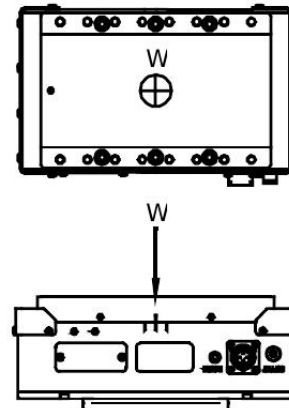

Case 3

Standard Ball Bearings:

$$L = \frac{W \times (D + 35)}{616} < 150$$

Heavy-duty Roller Bearings:

$$L = \frac{W \times (D + 35)}{308} < 1300$$

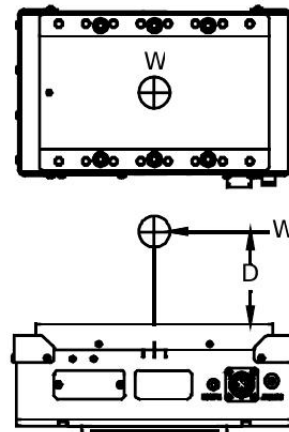

4.4 Pneumatic Connection

The *AFD1100* Adjustable Force Devices require a dry, non-lubricated, 5 µm filtered, 80 to 90 psi (5.5 – 6.2 bar) air supply. Failure to provide supply air to these specifications can degrade performance and will void any warranty repairs concerning pneumatic components. Filtered air is required since the high speed servo spool valve used in the AFD cannot tolerate ANY foreign material in the supply air. Additionally, a *minimum* 80 psi (5.5 bar) air pressure must be maintained at the supply air port for the device to operate within published specifications. Operating at lower air pressure can cause inferior force control performance and possibly instability. Operating the AFD at pressures over 90 psi (6.2 bar) will activate a pressure relief valve inside the tool. This valve prevents damage to the internal load cell due to operating the tool with excessive pressure. This relief valve is strictly a protective mechanism and should not be used as a pressure regulator device.

The pneumatic supply system should be configured as shown in the Figure 4.

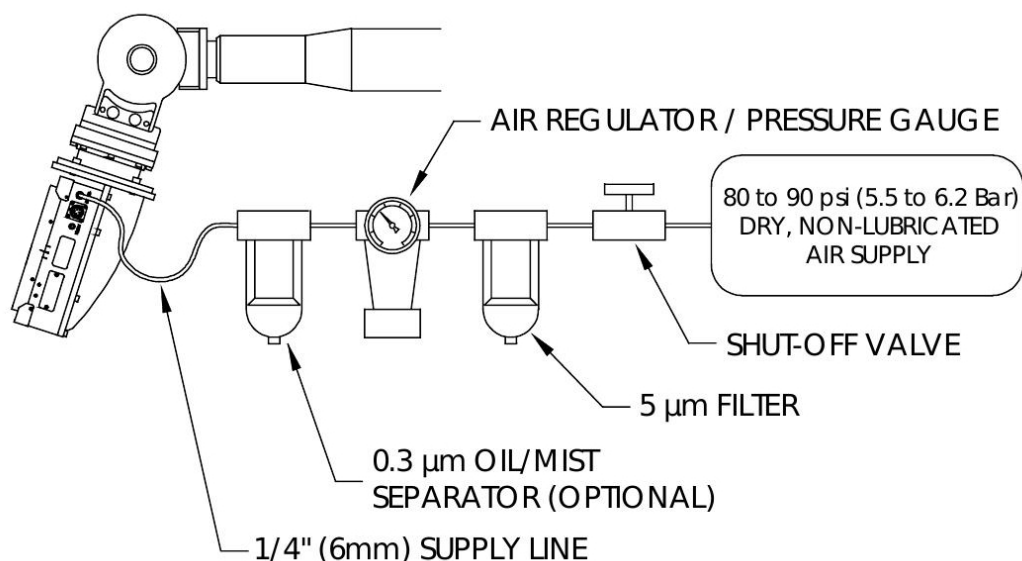

Figure 4. Pneumatic configuration

If water condensation is a problem in your air supply system, an air dryer device is highly recommended. The ideal solution is an industrial chiller dryer capable of reducing the dewpoint to less than 32° F (0°C). Moisture inside the force device will cause premature failure that will not be covered under warranty.

Under most circumstances the standard internal purge will provide sufficient air to keep the *AFD1100* free of contaminants. In applications where the environment contains very small suspended particulate matter, additional purge air flow must be used to ensure that the AFD remains clear of foreign matter. An auxiliary Purge Port on the *AFD1100* (See Figure 5.) provides a pneumatic connection to supply this additional air flow. The port accepts a metric R 1/8 tapered pneumatic fitting. PushCorp can provide fittings for English or metric tubing. The input pressure to the purge port can range from 10 PSI to 60 PSI (0.7 – 4.1 bar) with a flow rate of 0.5 to 2.0 SCFM (14 – 56 l/min) depending on the application. The purge air must be dry and non-lubricated, however it need only be filtered to 20 microns.

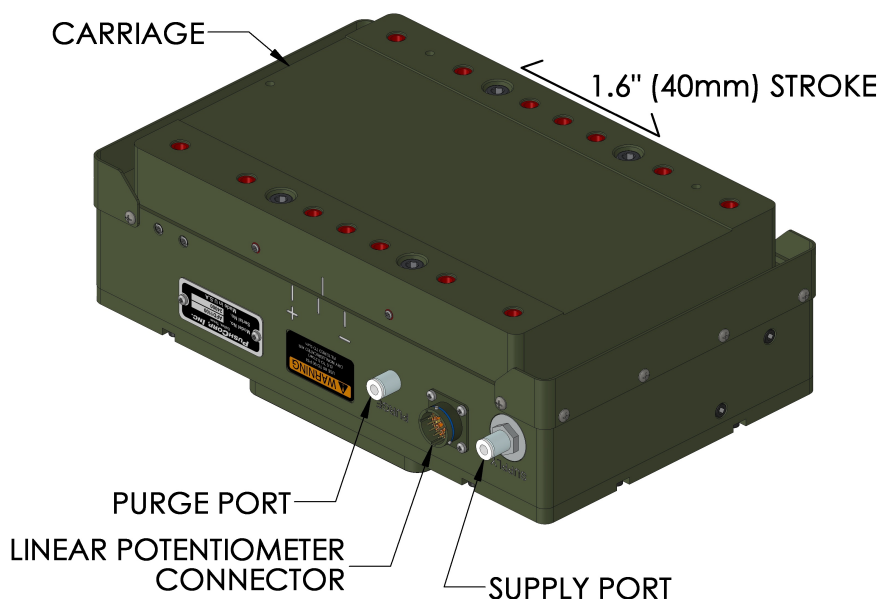

Figure 5. AFD1100 air connections

The Supply Line and Purge Line to the device should be 1/4 inch or 6mm diameter flexible polyurethane tubing. The tubing should be routed to the AFD such that there are no kinks and that there is plenty of slack to allow for manipulator motion. Before inserting the Supply Line into the force device air fitting, open the Shut-off valve to blow out any contaminants which may be in the line. The tubing can now be pushed into the self-locking fitting located on the side of the AFD. Charge the Supply Line with compressed air and verify that there are no air leaks and that there is a minimum of 80 PSI (5.5 bar) at the AFD. If a minimum air pressure cannot be achieved, then an auxiliary air compressor or booster pump with at least 2 SCFM (56 l/min) must be installed.

NOTE: PushCorp highly recommends the use of flexible polyurethane tubing as opposed to nylon tubing. This is because nylon tubing tends to crimp shut when it is bent. This severely limits air flow to the AFD and causes instability.

To remove the Supply Line, first discharge all air pressure in the system, then while pushing inward on the fitting's plastic ring, simultaneously pull the tubing out. Cover or plug the self-locking fitting any time the Supply Line is not connected. This will keep any contaminants from entering the AFD.

4.5 Internal Air Cartridge Filter

The *AFD1100* force device contains a Cartridge Filter in the base housing. The Cartridge Filter is designed to be the last line of defense to protect the AFD from contamination. The Cartridge Filter is not designed to be the sole means of AFD supply air filtration. The pneumatic supply system must be configured as described in Section 4.4. If the filter becomes clogged the *AFD1100* will not function properly. Replacement Cartridge Filters may be purchased from PushCorp (Part No. PAR01943-1), or from the manufacturer directly (Parker, Part No. 050-05-DQ). To remove the Cartridge Filter loosen the Cartridge Filter Holder located on the side of the AFD base housing, See Figure 4. Remove the Cartridge Filter and perform a visual inspection. The condition of the Cartridge Filter will give an indication of the quality of your supply air system. Place a new Cartridge Filter on the Cartridge Filter Holder and insert them into the AFD base housing. Tighten the Cartridge Filter Holder to a torque of 90 lb-in. (10 N-m).

5.0 Adjusting Carriage Preload

The required preload on the *AFD1100* Linear Rails has been set at the factory for optimal performance and, in general, should not require field adjustment. However, there are situations that could arise that cause the Linear Rails to need adjustment. Often a loose, or tight, Carriage on a new AFD is indicative of an improperly designed process equipment bracket. If the problem disappears when the brackets are removed then this is the case. Normally the Carriage will only require adjustment after removal for field service.

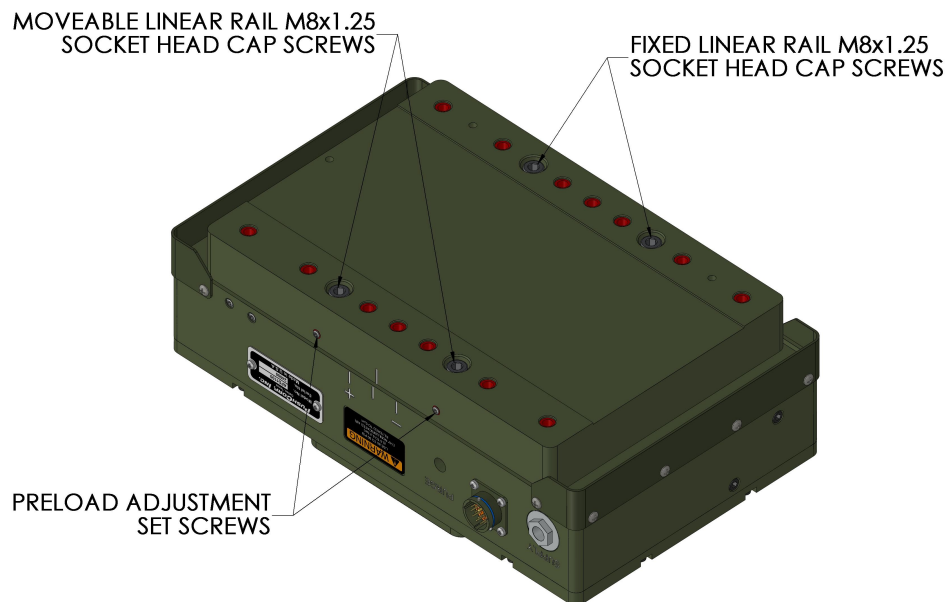

Figure 6. Carriage preload adjustment

To check for a loose Carriage, attempt to move the Carriage in a lateral direction as shown in Figure 6. If the Carriage moves or seems to exhibit any "slop", then the Linear Rail preload must be readjusted. A dial indicator is helpful, but not necessary to diagnose and correct a loose Carriage.

A Carriage that is too tight will require additional force to move. This is often detected during the weighing of the process equipment mounted on the Carriage. The weight will be inconsistent, varying higher or lower each time the process equipment is weighed.

The Linear Rails are attached to the underside of the Carriage with (4) four M8x1.25 Socket Head Cap Screws. Located on the side of the Carriage are the two Preload Adjustment Set Screws used to translate the Movable Linear Rail. Moving the Linear Rail associated with the Preload Adjustment Set Screws is all that is necessary to adjust the Carriage preload.

To perform the preload adjustment, follow the procedure below:

1. Check the tightness of the (2) two Fixed Linear Rail M8x1.25 Socket Head Cap Screws holding the Fixed Linear Rail opposite the Movable Linear Rail. If these fasteners are loose then the Fixed Linear Rail must be seated against the flange inside the Carriage. To do this, loosen all (4) four fasteners located on the face of the Carriage just enough to allow the Linear Rails to move. Next tighten the Preload Adjustment Set Screws to force the Fixed Linear Rail to seat against the flange. Tighten the (2) two Fixed Linear Rail M8x1.25 Socket Head Cap Screws, which hold the Fixed Linear Rail, to the torque specified in Section 6.0. The Fixed Linear Rail is now correctly seated and the Preload Adjustment Set Screws can be loosened. You are now ready to continue on to preload the Carriage Linear Rails.
2. To preload the Carriage Linear Rails, loosen the Movable Linear Rail M8x1.25 Socket Head Cap Screws holding the Movable Linear Rail only enough to allow the rail to move relative to the inside Carriage surface. The Carriage has slotted holes on the Movable Linear Rail side which allow the rail to move in the same direction as the Preload Adjustment Set Screws. Make sure that the Movable Linear Rail M8x1.25 Socket Head Cap Screws are loose before attempting to set the preload.
3. If a dial indicator is available, place it against the Carriage surface that contains the Preload Adjustment Set Screws. Attempt to move the Carriage laterally while monitoring the dial indicator. If the reading on the dial indicator varies, then gradually tighten each of the Preload Adjustment Set Screws. Note that one of the Preload Adjustment Set Screws could require more adjustment than the other. When the dial indicator ceases to vary, the preload is set correctly. Do not continue to tighten the Preload Adjustment Set Screws. Too much preload on the Linear Rails will cause excessive friction resulting in force errors.
4. If a dial indicator is not available, the preload can be adjusted by feel. Attempt to move the Carriage laterally and feel for movement. If the Carriage moves rotate each of the Preload Adjustment Set Screws no more than 5 degrees. As soon as no lateral movement can be felt, stop rotating the Preload Adjustment Set Screws. Note that one of the Preload Adjustment Set Screws could require more adjustment than the other. Do not over tighten the Preload Adjustment Set Screws. Over tightening the Preload Adjustment Set Screws will result in excessive friction and possible deformation of the Carriage. (If the adjustment cannot be performed, contact the factory service center.)

The Carriage preload should now be correct.

5. After verifying that the Carriage no longer moves laterally, tighten the (2) two Movable Linear Rail M8x1.25 Socket Head Cap Screws on the Moveable Rail side to the torque specified in Section 6.0.

6.0 Technical Specifications

Maximum Applied Force:	100 lbs. (444N)
Maximum Payload:	80 lbs. (36 kg)
Tool Weight: AFD1100-1:	34 lbs. (16 kg)
AFD1100-2:	24 lbs. (11 kg)
AFD1100-3:	24 lbs. (11 kg)
Compliant Stroke:	1.6 in. (40 mm)
Force Accuracy:	+/-0.2 lb. (+/-1 N)
Response Time:	300ms
Temperature:	50° to 122° F (10° to 50° C)
Humidity:	5% to 95%, Non-Condensing
Supply air:	Non-lubricated, Dry, 5 μ m Filtered, 80 psi (5.5 bar) Min., 90 psi (6.2 Bar) Max., 3 SCFM (85 l/min)

Specifications subject to change without notice. These values are based on measurements taken in a laboratory environment. Real-world results may be degraded due to external factors beyond PushCorp's control.

Fastener Tightening Torque Specs					
Fastener Size	Torque			Minimum Depth	
	in.-lbs.	ft.-lbs.	N·m	in.	mm
M4 x .7	50	4.2	5.6	0.17	4.3
M5 x .8	85	7.1	9.6	0.21	5.3
M6 x 1	140	11.7	15.8	0.25	6.3
M8 x 1.25	348	29.0	39.3	0.33	8.4
M10 x 1.5	600	50.0	67.8	0.41	10.5

7.0 Preventative Maintenance Schedule

It is highly recommended to adhere to the preventative maintenance schedule in order help extend the longevity of the specified PushCorp, Inc. equipment. Failing to do so could cause a loss in functionality as well as a decrease in product life.

PUSHCORP, INC. AFD			
Maintenance	Weekly	Monthly	3 Months
Remove debris from AFD	X		
Check that the connectors are not bent/damaged	X		
Check to see if the carriage moves back and forth easily	X		
Check for flow in the purge and supply ports		X	

Agency/Organization: _____

Date Completed: _____