

DETAIL A
SCALE 1.000

CUSTOMER DRAWING

This drawing is the property of Rev-A-Shelf (RAS) and is disclosed in confidence to the extent its subject matter is original to RAS. Any vendor receiving this drawing from RAS shall hold and use this drawing for the sole benefit of RAS and shall not disclose it to, or use or reproduce it for any third party, or perform any act adverse to the interest of RAS with respect to this drawing without the express written permission of RAS. Vendors shall not revise any physical, dimensional or performance characteristic unless authorized by Rev-A-Shelf Engineering.

REV.	DATE	BY	DESCRIPTION OF CHANGE

INCH [MM]	AMERICAN PROJECTION 	BY	DATE	REV-A-SHELF, INC.	
		DRAWN	LCS 6-03-22	SIZE	DOUBLE 35QT BASE 24 1-5/8 FACE
TOLERANCES		MATERIAL	DRAWING NO.	SCALE	
MAT.	DEC.		4WCTM-24DM2-162	0.188	
(WOOD)	.XX ±.03 [.8mm]	FINISH	PART NO.	SHEET OF	
(OTHER)	.XX ±.02 [.5mm]		4WCTM-24DM2-162	1 OF 2	
(ALL)	.XXX ±.005 [.13 mm]				
FRACTIONS	±1/32 [.8 mm]				

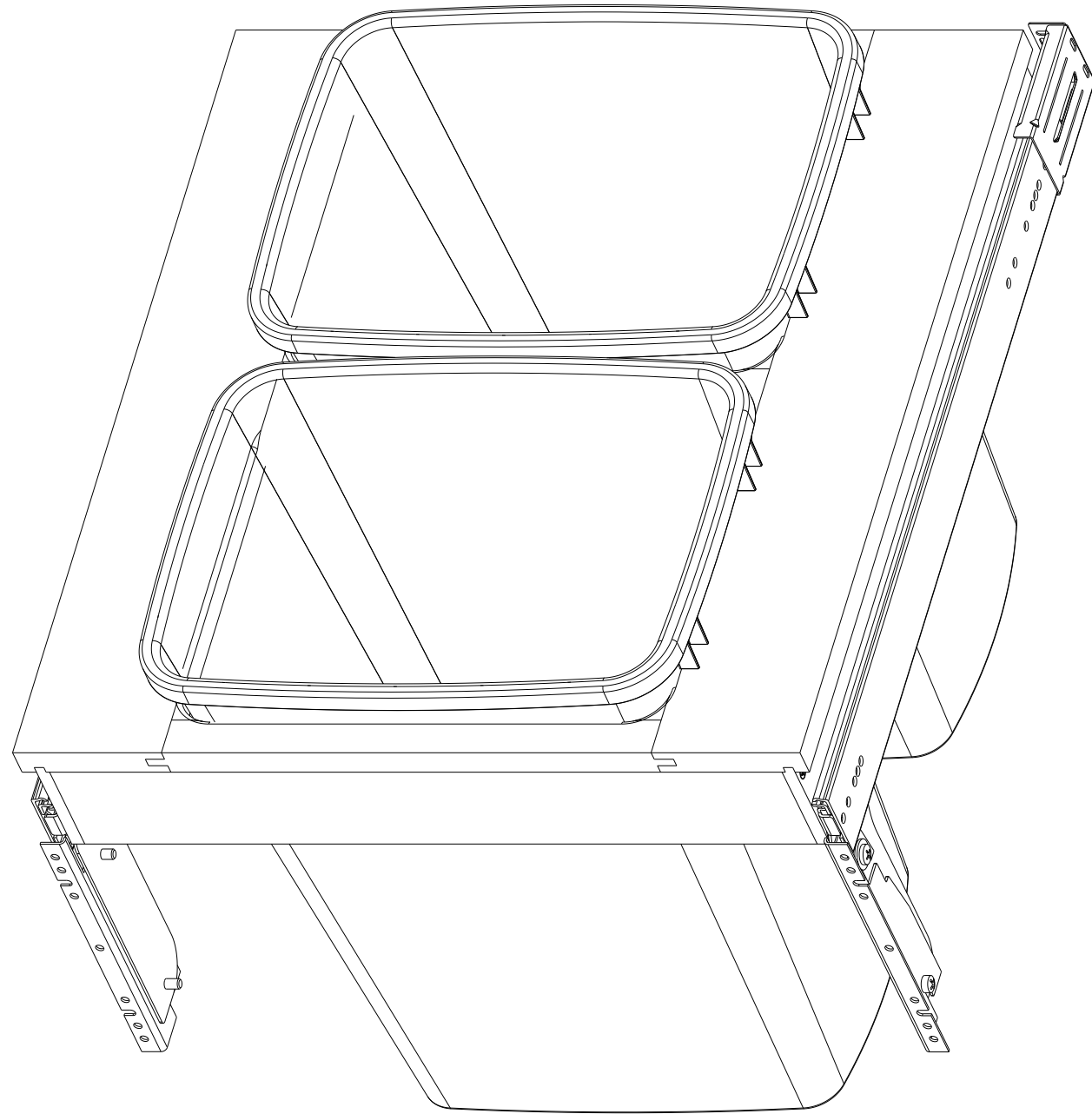

PART DIMENSIONS		
	MIN	MAX
WIDTH	20.75	
DEPTH	22.75	24.00
HEIGHT	17.85	
CONTAINER CAPACITY	35	
CONTAINER UOM	QT	

MIN CABINET OPENING	
WIDTH	20.75
DEPTH	22.75
HEIGHT	18.35

SLIDE SPECIFICATIONS				
SLIDE TYPE	BALL BEARING	SLIDE EXTENSION	1-1/2" O.T.	MAX WEIGHT RATING
SLIDE CLOSING	NORMAL	SLIDE LENGTH	22.00 [560]	
SLIDE MOUNTING	SIDE	SLIDE FINISH	ZINC	150LB

CUSTOMER DRAWING

This drawing is the property of Rev-A-Shelf (RAS) and is disclosed in confidence to the extent its subject matter is original to RAS. Any vendor receiving this drawing from RAS shall hold and use this drawing for the sole benefit of RAS and shall not disclose it to, or use or reproduce it for any third party, or perform any act adverse to the interest of RAS with respect to this drawing without the express written permission of RAS. Vendors shall not revise any physical, dimensional or performance characteristic unless authorized by Rev-A-Shelf Engineering.

REV.	DATE	BY	DESCRIPTION OF CHANGE

INCH [MM]	AMERICAN PROJECTION 	DRAWN	BY	DATE	REV-A-SHELF, INC.
		LCS		6-03-22	
TOLERANCES		ANGLES ±1/2°	MATERIAL	DRAWING NO. 4WCTM-24DM2-162	SCALE 0.25
MAT.	DEC.				
(WOOD)	.XX ±.03 [.8mm]				
(OTHER)	.XX ±.02 [.5mm]				
(ALL)	.XXX ±.005 [.13 mm]				
FRACTIONS	±1/32 [.8 mm]				