

# SONDER

LIVING

CALVING DINING TABLE

Thank you for choosing this quality product. Be sure to check all packaging materials carefully for small parts that may have loosened inside the carton during shipment and place on a non-abrasive surface.

## IMPORTANT

These parts can be cumbersome and heavy to some people, therefore, the assistance of two or more people are recommended in order to prevent personal injury and ensure the furniture is not damaged during the assembly Process.







## PART LIST

- A. [1] TABLETOP
- B. [2] BASE
- C. [1] STRETCHER

## INSTRUCTIONS

1. Gently Turn both bases (B) upside down with inside surface facing each other and leave enough spaces to assemble the stretcher (C) in-between as shown in FIGURE 01.
2. Secure the threaded rods (1) to the fixed nut in the Bases (B) simply turning it manually clockwise direction.
3. Put the Stretcher (C) to the Base (B) so the threaded rod (1) go through the bore holes. Insert curved washer (2), lock washer (3) and place hex nuts (4) on threaded rod (1) then tighten the hex nuts (4) with wrench (5), as illustrated in FIGURE 01.
4. Repeat this step for the other Base (B).

## HARDWARE LIST

NO.	ITEM	DESCRIPTION	QTY.
1		Threaded Rod	2 pcs.
2		Flat Washer	10 pcs.
3		Lock Washer	10 pcs.
4		Hex Nut	2 pcs.
5		Wrench	1 pc.
6		Allen Bolt	8 pcs.
7		Allen Key	1 pc.

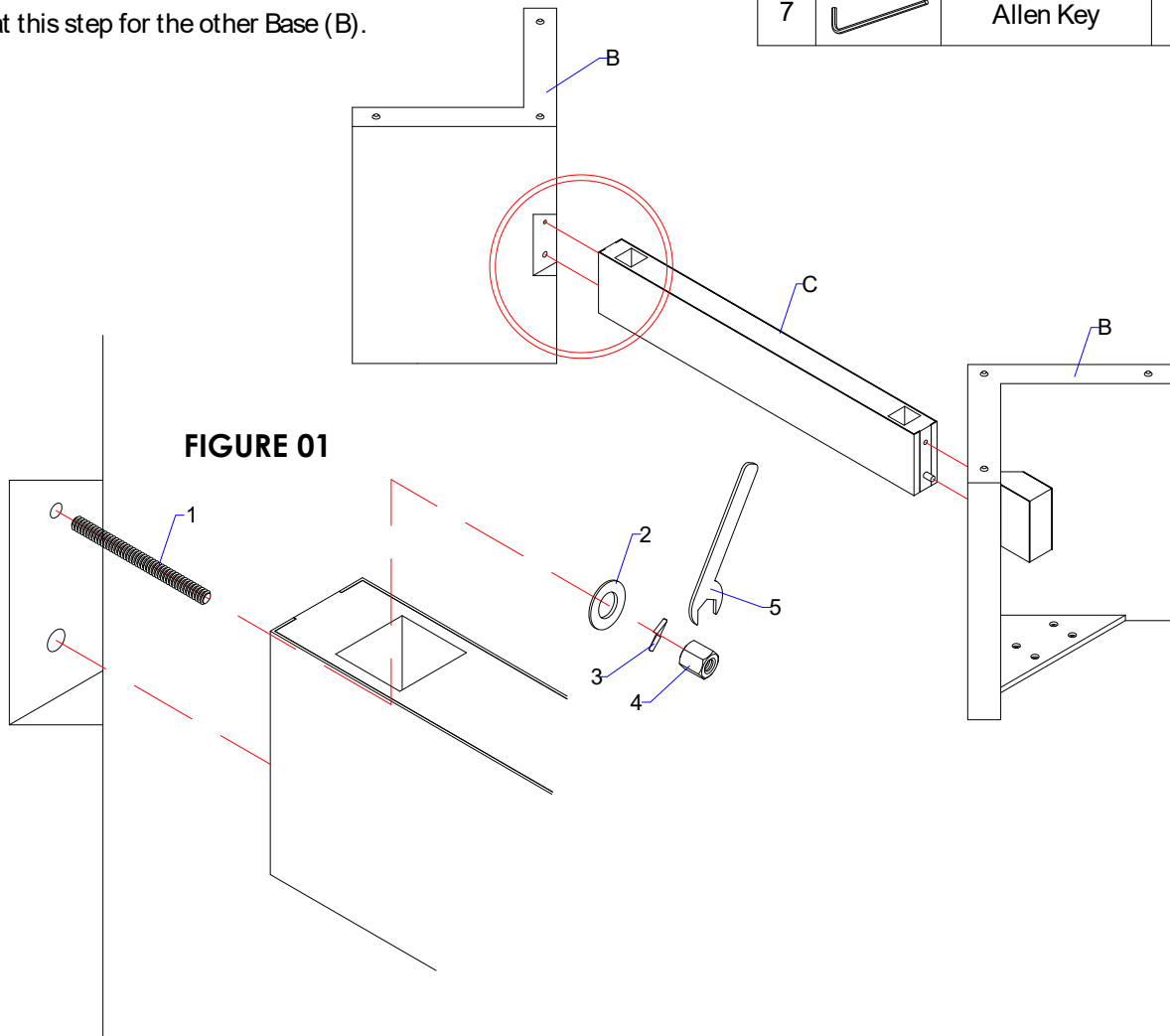

2. After assembly, gently turn the base in upright position and place on your desired location where the table to be in when fully assembled.
3. Bring the table top (A) and set it on the assembled base. Align the fixed nuts at the bottom of the top to the holes on top of the base. Insert Allen bolts (6) together with Lock washer (3) and Flat washer (2) into each fixed nuts through the holes on top of the base, then tighten them by using Allen key (7). DO NOT OVER TIGHTEN. See FIGURE 02.
4. Assembly is complete.

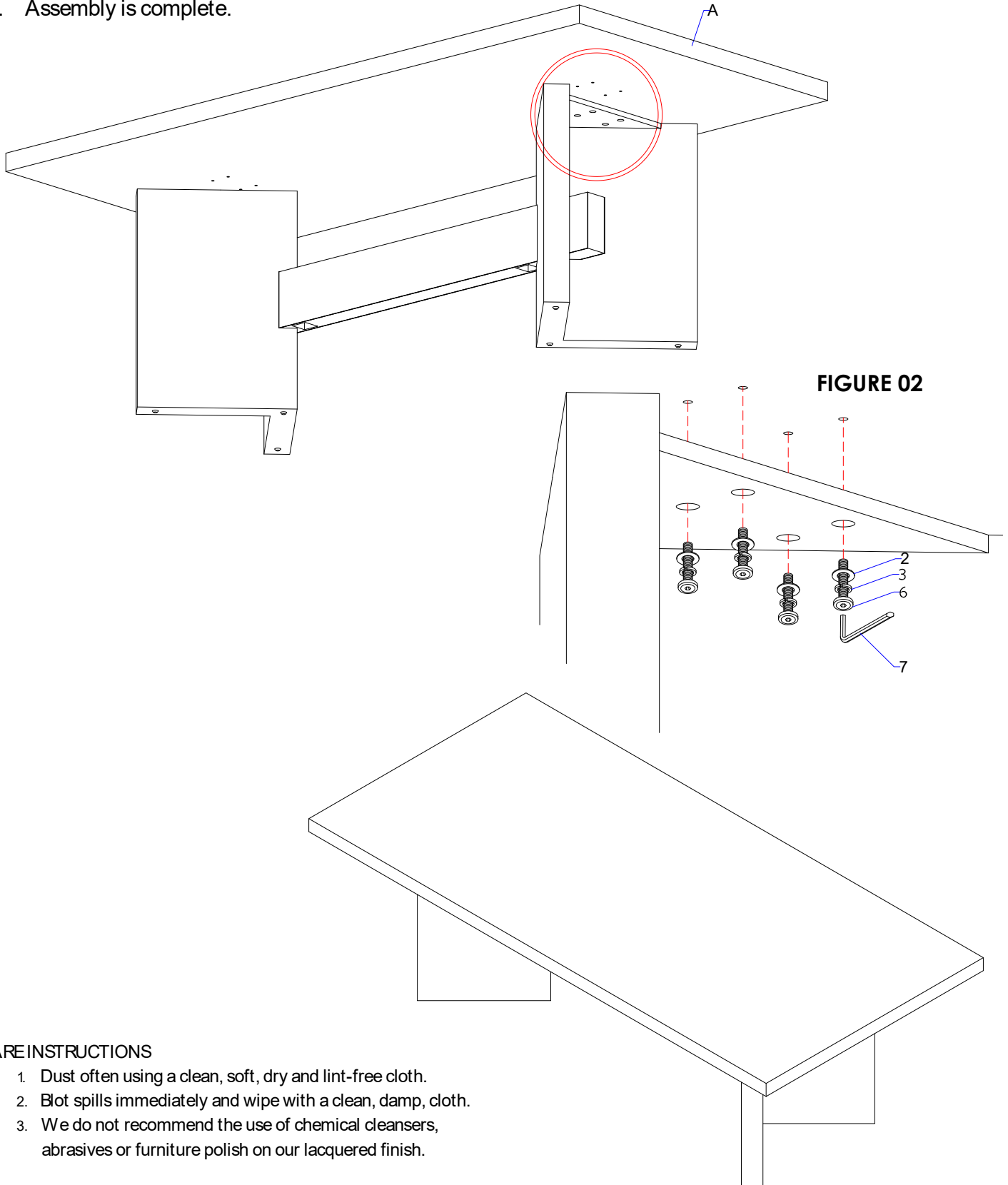

**CARE INSTRUCTIONS**

1. Dust often using a clean, soft, dry and lint-free cloth.
2. Blot spills immediately and wipe with a clean, damp, cloth.
3. We do not recommend the use of chemical cleansers, abrasives or furniture polish on our lacquered finish.

**IMPORTANT SAFETY INSTRUCTIONS**

1. Please read all instructions carefully before assembling.
2. For your safety, assembly by two or more adults is strongly recommended.
3. Keep instructions for future use.
4. Use only vendor supplied hardware to assemble. Using unauthorized hardware could jeopardize the structural integrity of the item.