





Thank you for choosing this quality product. Be sure to check all packaging materials carefully for small parts that may have become loose during shipment and place all parts on a non-abrasive surface.

**IMPORTANT** :These parts can be cumbersome and heavy to some people, therefore the assistance of two or more people is recommended in order to prevent personal injury and ensure the furniture is not damaged during the assembly Process.

### PART LIST

- A [1] TABLE TOP
- B [1] TABLE BASE

### HARDWARE LIST

NO	DESCRIPTION	QTY
1	 ALLEN HEAD BOLT	8
2	 LOCK WASHER	8
3	 PLAIN WASHER	8
4	 ALLEN WRENCH	1

### INSTRUCTIONS

- Gently, lay the table top (A) upside down on a soft flat surface. Attach the table base into the table top, align and insert Allen bolt (1) together with lock washer (2) and flat washer (3) to each hole under top through the hole on the stretcher of the base. Tighten all the bolts by using wrench (4). **DO NOT OVER TIGHTEN**. See **FIGURE 01**.
- After assembly, turn the table upright on desired location. Check the table leveling, and adjust the levelers at the bottom of the base if necessary. See **FIGURE 02**.

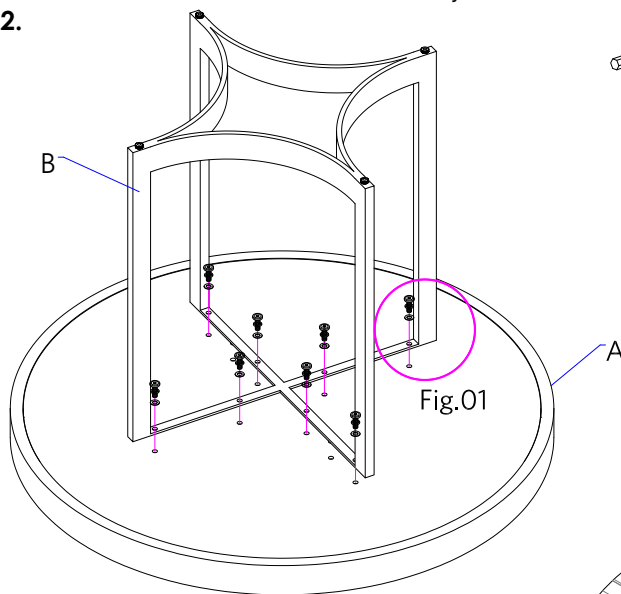

**FIGURE 01**

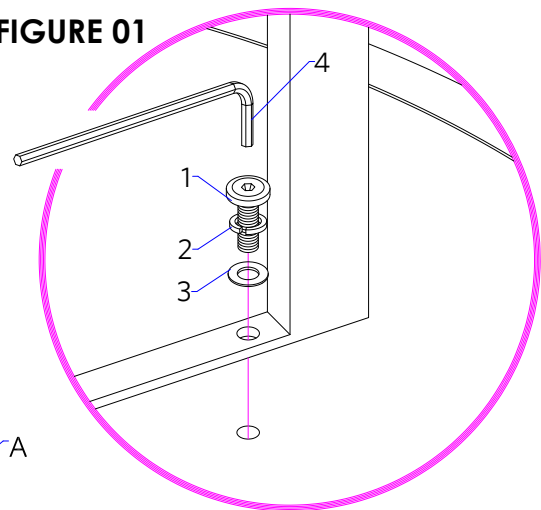

**FIGURE 02**

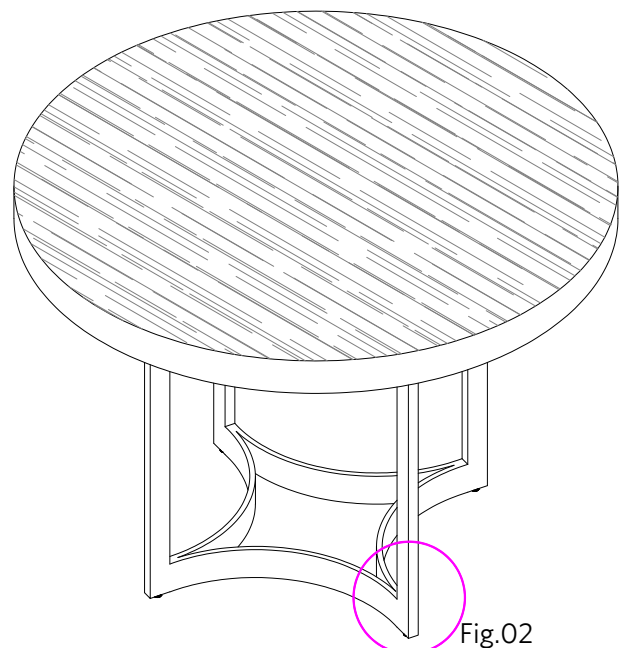
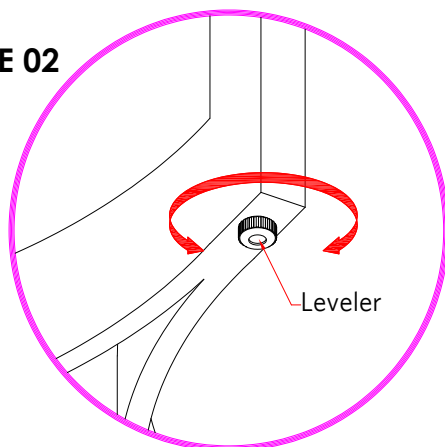

### CARE INSTRUCTIONS

- Dust often using a clean, soft, dry and lint-free cloth.
- Blot spills immediately and wipe with a clean, damp, cloth.
- We do not recommend the use of chemical cleansers, abrasives or furniture polish on our lacquered finish.