

This drawing is the property of Rev-A-Shelf (RAS) and is disclosed in confidence to the extent its subject matter is original to RAS. Any vendor receiving this drawing from RAS shall hold and use this drawing for the sole benefit of RAS and shall not disclose it to, or use or reproduce it for any third party, or perform any act adverse to the interest of RAS with respect to this drawing without the express written permission of RAS. Vendors shall not revise any physical, dimensional or performance characteristic unless authorized by Rev-A-Shelf Engineering.

REV.	DATE	BY	DESCRIPTION OF CHANGE
B	2/1/23	BKT	ECN23-009
A	2/17/2	BKT	ECN21-061

INCH [MM]	AMERICAN PROJECTION 	BY	DATE	REV-A-SHELF, INC. 8" BLUM 449 SIDE & BOTTOM MOUNT BASE CABINET PULLOUT	
		DRAWN	BKT 3/20/18		
TOLERANCES		MATERIAL		DRAWING NO.	SCALE
MAT. DEC. (WOOD) .XX ±.03 [8mm] (OTHER) .XX ±.02 [5mm] (ALL) .XXX ±.005 [13 mm] FRACTIONS ±1/32 [8 mm]		FINISH		449-BCSC-8C_CUST	0.125
ANGLES ±1/2°				PART NO.	SHEET OF
				449-BCSC-8C	1 2

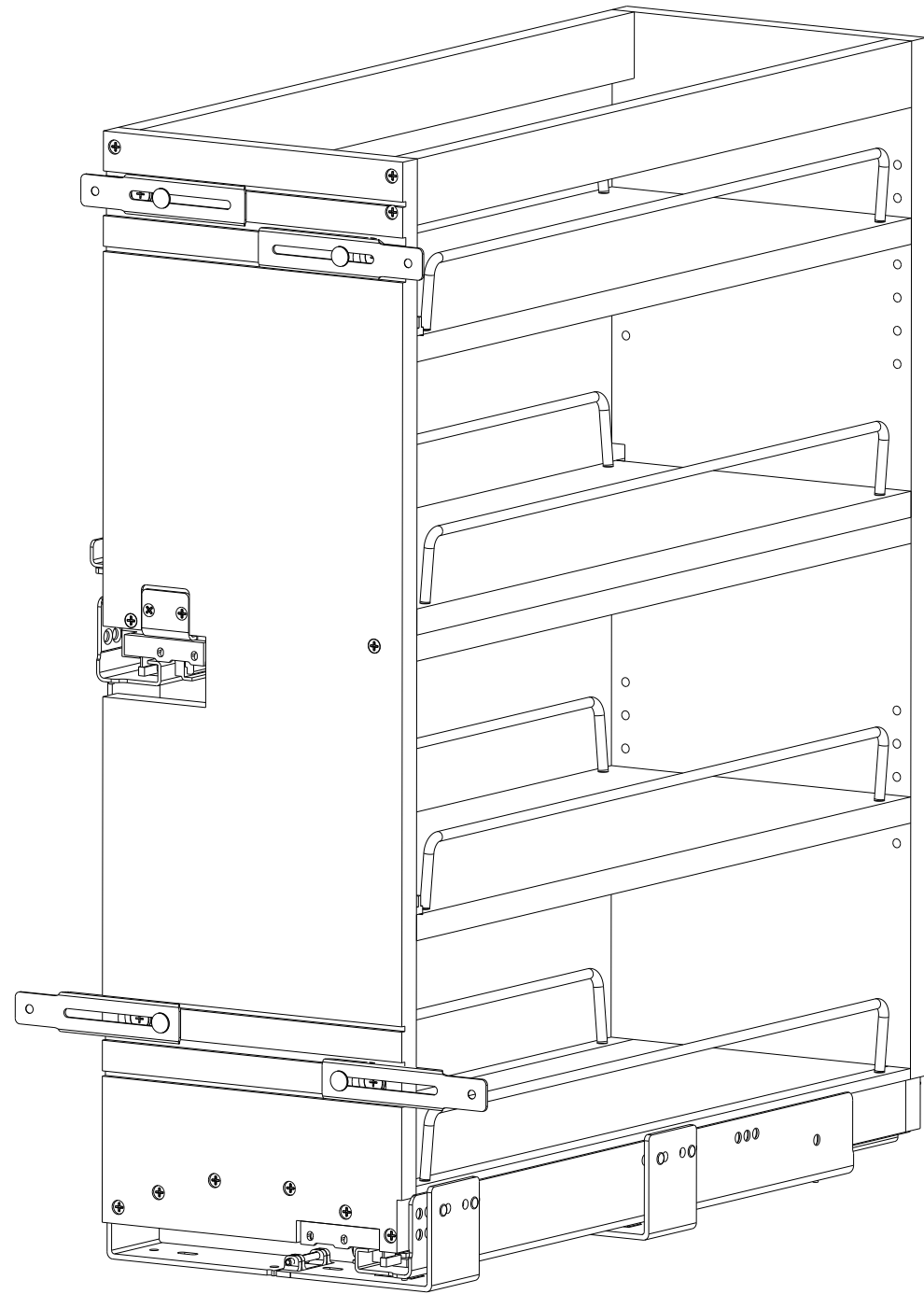

PART DIMENSIONS	
	MIN
WIDTH	9.29 [236]
DEPTH	21.75 [552,5]
HEIGHT	25.60 [650,3]

MIN CABINET OPENING				
	FACE FRAME	FRAMELESS	INSET FACE FRAME	INSET FRAMELESS
WIDTH	8.50 [215,9]	9.25 [235]	8.50 [215,9]	9.25 [235]
DEPTH	21.75 [552,5]	21.75 [552,5]	22.50 [571,5]	22.50 [571,5]
HEIGHT	25.85 [656,6]	25.85 [656,6]	25.85 [656,6]	25.85 [656,6]

SLIDE SPECIFICATIONS				
SLIDE TYPE	BLUM UNDERMOUNT	SLIDE EXTENSION	FULL	MAX WEIGHT RATING
SLIDE CLOSING	SELF/SOFT	SLIDE LENGTH	21.653 [550]	
SLIDE MOUNTING	BOTTOM	SLIDE FINISH	ZINC	150LB

CUSTOMER DRAWING

This drawing is the property of Rev-A-Shelf (RAS) and is disclosed in confidence to the extent its subject matter is original to RAS. Any vendor receiving this drawing from RAS shall hold and use this drawing for the sole benefit of RAS and shall not disclose it to, or use or reproduce it for any third party, or perform any act adverse to the interest of RAS with respect to this drawing without the express written permission of RAS. Vendors shall not revise any physical, dimensional or performance characteristic unless authorized by Rev-A-Shelf Engineering.

REV.	DATE	BY	DESCRIPTION OF CHANGE
B	2/1/23	BKT	ECN23-009
A	2/17/2	BKT	ECN21-061

INCH [MM]	AMERICAN PROJECTION	DRAWN	BY	DATE	REV-A-SHELF, INC.	
			BKT	3/21/18	SIZE B	8" BLUM 449 SIDE & BOTTOM MOUNT BASE CABINET PULLOUT
TOLERANCES		MATERIAL		DRAWING NO.		SCALE
MAT.	DEC.	FINISH		449-BCSC-8C-CUST		0.250
(WOOD) .XX ±.03 [.8mm]				PART NO.		SHEET 2 OF 2
(OTHER) .XX ±.02 [.5mm]	ANGLES ±1/2°			449-BCSC-8C		
(ALL) .XXX ±.005 [.13 mm]						
FRACTIONS ±1/32 [.8 mm]						