

CUSTOMER DRAWING

This drawing is the property of Rev-A-Shelf (RAS) and is disclosed in confidence to the extent its subject matter is original to RAS. Any vendor receiving this drawing from RAS shall hold and use this drawing for the sole benefit of RAS and shall not disclose it to, or use or reproduce it for any third party, or perform any act adverse to the interest of RAS with respect to this drawing without the express written permission of RAS. Vendors shall not revise any physical, dimensional or performance characteristic unless authorized by Rev-A-Shelf Engineering.

REV.	DATE	BY	DESCRIPTION OF CHANGE

INCH [MM]	AMERICAN PROJECTION	BY	DATE	REV-A-SHELF, INC.	
		KRR	6-28-10	SIZE	B
TOLERANCES		MATERIAL		DRAWING NO.	
MAT. DEC. (WOOD) .XX ±.03 [8mm] (OTHER) .XX ±.02 [5mm] (ALL) .XXX ±.005 [13mm] FRACTIONS ±1/32 [8mm]		FINISH		4VHTM-1520DM-1_CUST	
ANGLES ±1/2°		SCALE		0.150	
				PART NO.	
				4VHTM-1520DM-1	
				SHEET OF	
				1 2	

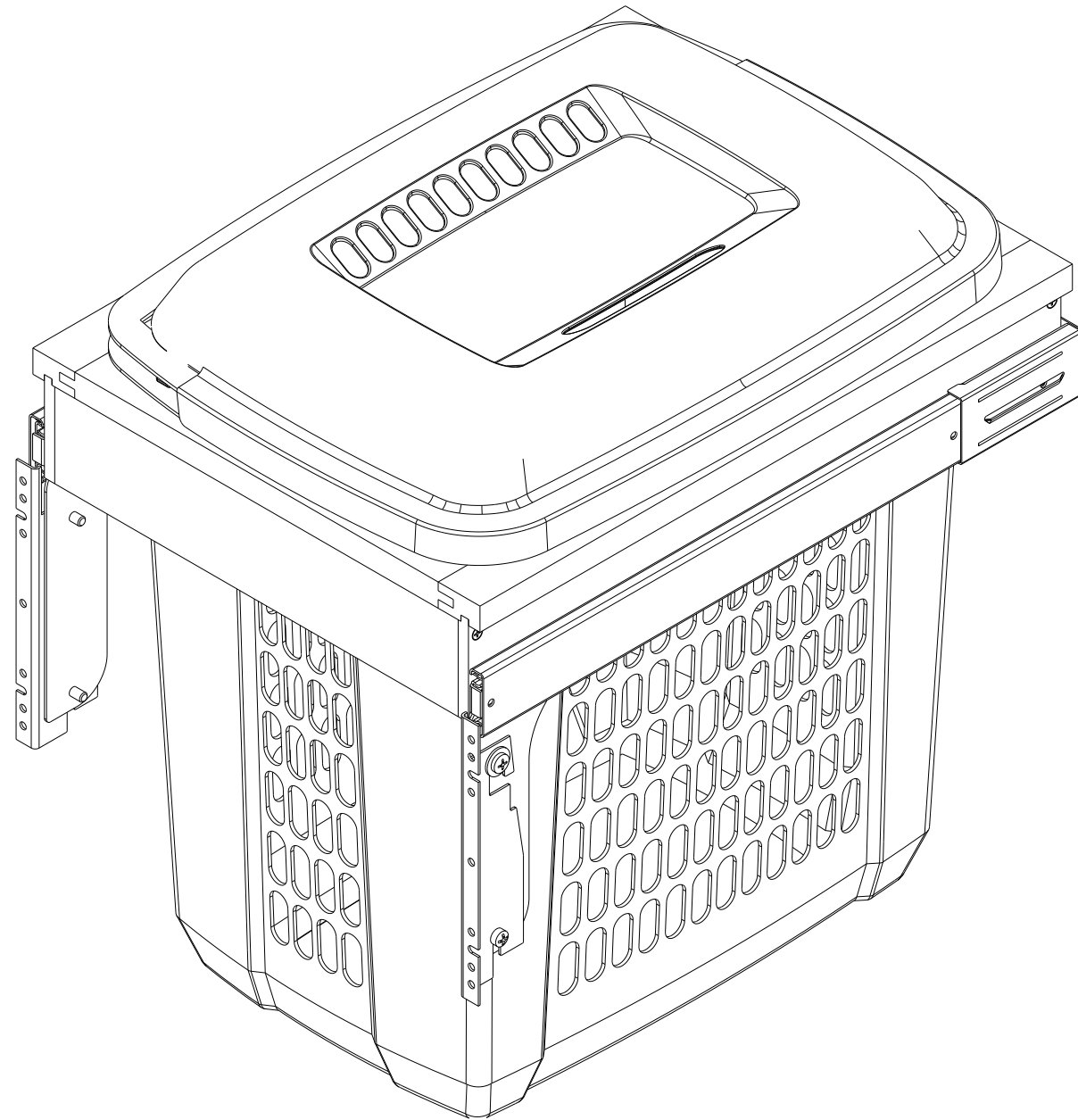

PART DIMENSIONS		
	MIN	MAX
WIDTH		15.08
DEPTH	19.75	21.75
HEIGHT		19.99
WEIGHT		
CONTAINER CAPACITY	1.5	
CONTAINER UOM	BUSHEL	

MIN CABINET OPENING	
WIDTH	15.00
DEPTH	20.00
HEIGHT	20.50

PRODUCT MAX WEIGHT RATING

SLIDE SPECIFICATIONS				
SLIDE TYPE	BALL BEARING	SLIDE EXTENSION	2" OVER TRAVEL	MAX WEIGHT RATING
SLIDE CLOSING	NORMAL	SLIDE LENGTH	500MM (20")	
SLIDE MOUNTING	SIDE/BACK	SLIDE FINISH	ZINC COATED	100LB

CUSTOMER DRAWING

This drawing is the property of Rev-A-Shelf (RAS) and is disclosed in confidence to the extent its subject matter is original to RAS. Any vendor receiving this drawing from RAS shall hold and use this drawing for the sole benefit of RAS and shall not disclose it to, or use or reproduce it for any third party, or perform any act adverse to the interest of RAS with respect to this drawing without the express written permission of RAS. Vendors shall not revise any physical, dimensional or performance characteristic unless authorized by Rev-A-Shelf Engineering.

REV.	DATE	BY	DESCRIPTION OF CHANGE

INCH [MM]	AMERICAN PROJECTION	DRAWN	BY	DATE	REV-A-SHELF, INC.
			KRR	6-28-10	
			SIZE	VANITY PULL OUT HAMPER	
			MATERIAL	DRAWING NO.	SCALE
			FINISH	4VHTM-1520DM-1_CUST	0.250
				PART NO.	SHEET OF
				4VHTM-1520DM-1	2 OF 2

TOLERANCES
 MAT. DEC.
 (WOOD) .XX ±.03 [.8mm]
 (OTHER) .XX ±.02 [.5mm]
 (ALL) .XXX ±.005 [.13 mm]
 FRACTIONS ±1/32 [.8 mm]

ANGLES ±1/2°