

CUSTOMER DRAWING

This drawing is the property of Rev-A-Shelf (RAS) and is disclosed in confidence to the extent its subject matter is original to RAS. Any vendor receiving this drawing from RAS shall hold and use this drawing for the sole benefit of RAS and shall not disclose it to, or use or reproduce it for any third party, or perform any act adverse to the interest of RAS with respect to this drawing without the express written permission of RAS. Vendors shall not revise any physical, dimensional or performance characteristic unless authorized by Rev-A-Shelf Engineering.

REV.	DATE	BY	DESCRIPTION OF CHANGE
A	2-5-20	KRR	RENAMED

INCH [MM]	AMERICAN PROJECTION 	BY	DATE	REV-A-SHELF, INC.	
		DRAWN	DKK 9-10-15	SIZE B	24" BLUM SC DRAWER
TOLERANCES MAT. DEC. (WOOD) .XX ±.03 [.8mm] (OTHER) .XX ±.02 [.5mm] (ALL) .XXX ±.005 [.13 mm] FRACTIONS ±1/32 [.8 mm]		ANGLES ±1/2°	MATERIAL	DRAWING NO. 4WDB4-24SC-1	SCALE 0.188
		FINISH	PART NO. 4WDB4-24SC-1	SHEET OF 1 2	

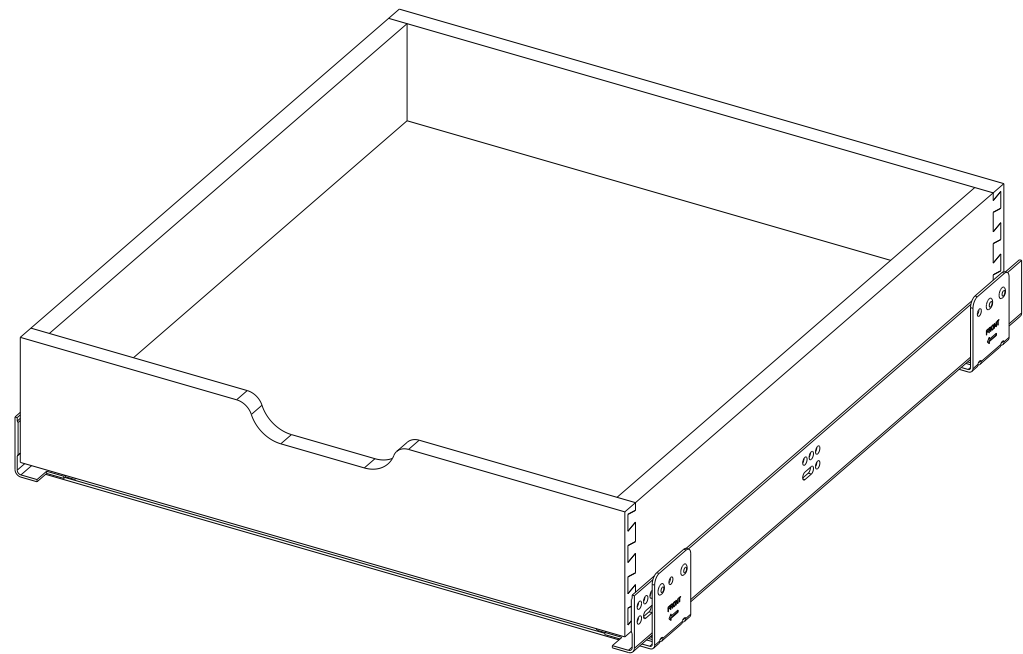

PART DIMENSIONS	
WIDTH	20.06 [509,6]
DEPTH	21.65 [550]
HEIGHT	4.85 [123,2]
CONTAINER CAPACITY	
CONTAINER UOM	

MIN CABINET OPENING				
	FACE FRAME	FRAMELESS	INSET FACE FRAME	INSET FRAMELESS
WIDTH	21.00 [533]	21.00 [533]	21.00 [533]	21.00 [533]
DEPTH	21.75 [552]	21.75 [552]	22.50 [572]	22.50 [572]
HEIGHT	5.00 [127]	5.00 [127]	5.00 [127]	5.00 [127]

SLIDE SPECIFICATIONS				
SLIDE MANUFACTURER	BLUM			
SLIDE PART NUMBER	563H5330B	RELEASE PART NUMBER	T51-1801	
SLIDE TYPE	UNDERMOUNT	SLIDE EXTENSION	FULL	MAX WEIGHT RATING
SLIDE CLOSING	SOFT	SLIDE LENGTH	21.00 [533]	
SLIDE MOUNTING	BOTTOM	SLIDE FINISH	ZINC	90 LB

CUSTOMER DRAWING

This drawing is the property of Rev-A-Shelf (RAS) and is disclosed in confidence to the extent its subject matter is original to RAS. Any vendor receiving this drawing from RAS shall hold and use this drawing for the sole benefit of RAS and shall not disclose it to, or use or reproduce it for any third party, or perform any act adverse to the interest of RAS with respect to this drawing without the express written permission of RAS. Vendors shall not revise any physical, dimensional or performance characteristic unless authorized by Rev-A-Shelf Engineering.

REV.	DATE	BY	DESCRIPTION OF CHANGE
A	2-5-20	KRR	RENAMED

INCH [MM]	AMERICAN PROJECTION	DRAWN	BY	DATE	REV-A-SHELF, INC.
			DKK	9-10-15	
			MATERIAL	DRAWING NO.	SCALE
			FINISH	4WDB4-24SC-1	0.188
				PART NO.	SHEET OF
				4WDB4-24SC-1	2 OF 2

TOLERANCES  
 MAT. DEC.  
 (WOOD) .XX ±.03 [.8mm]  
 (OTHER) .XX ±.02 [.5mm]  
 (ALL) .XXX ±.005 [.13 mm]  
 FRACTIONS ±1/32 [.8 mm]

ANGLES  
 ±1/2°