

SCALE 0.250

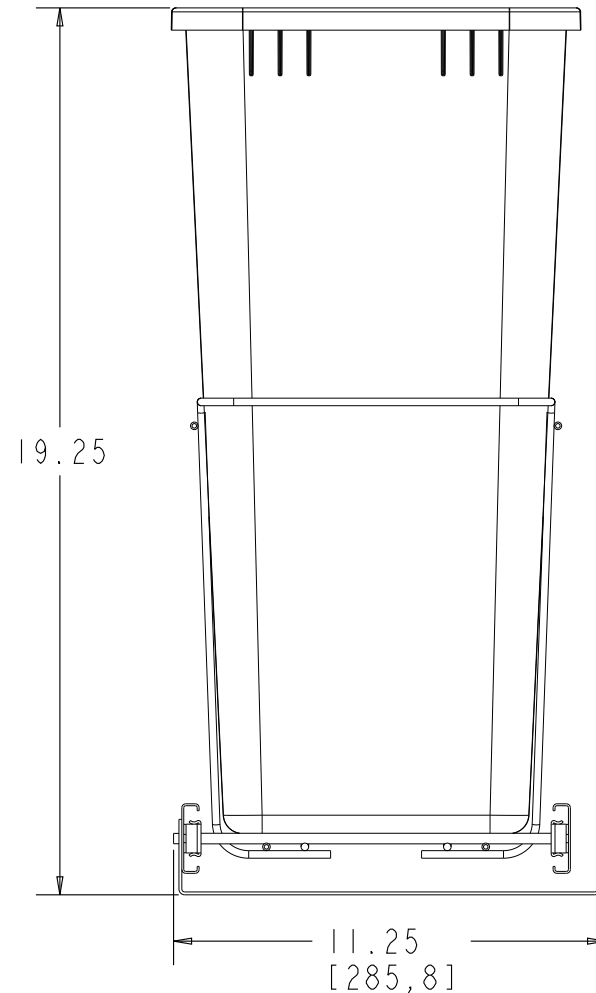
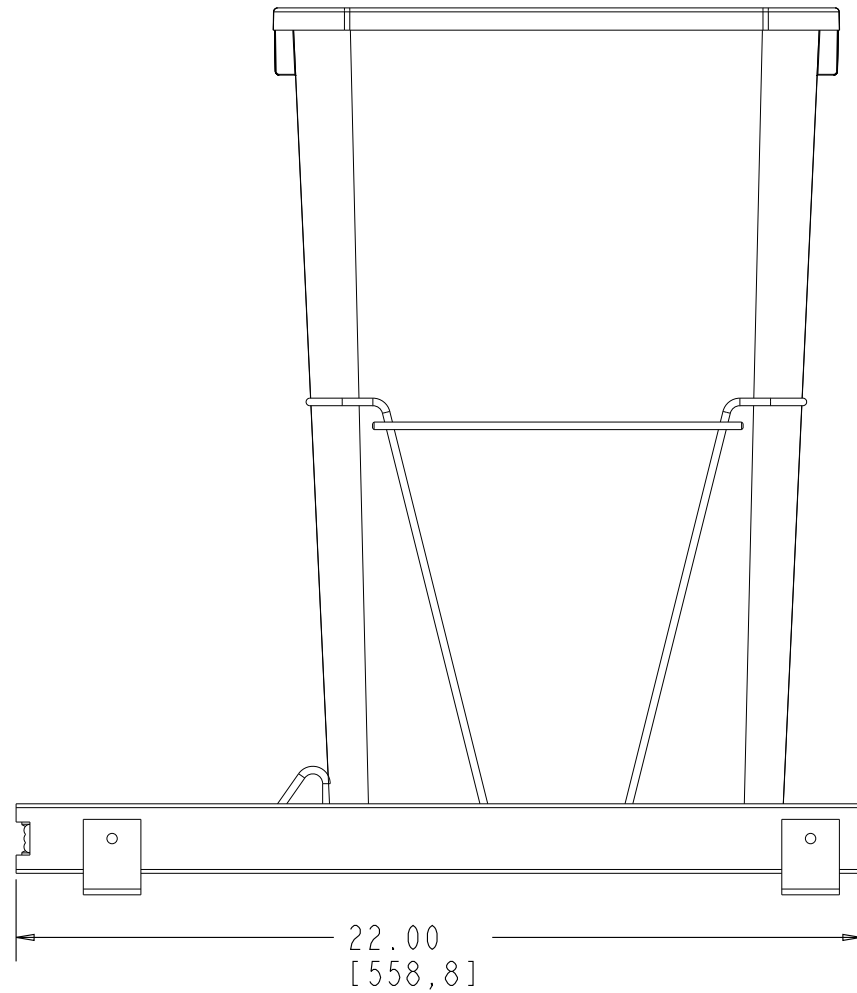

CUSTOMER DRAWING

This drawing is the property of Rev-A-Shelf (RAS) and is disclosed in confidence to the extent its subject matter is original to RAS. Any vendor receiving this drawing from RAS shall hold and use this drawing for the sole benefit of RAS and shall not disclose it to, or use or reproduce it for any third party, or perform any act adverse to the interest of RAS with respect to this drawing without the express written permission of RAS. Vendors shall not revise any physical, dimensional or performance characteristic unless authorized by Rev-A-Shelf Engineering.

REV.	DATE	BY	DESCRIPTION OF CHANGE

INCH [MM]	AMERICAN PROJECTION 	BY	DATE	REV-A-SHELF, INC.	
		DRAWN	KRR	3-3-23	SIZE B
TOLERANCES		MATERIAL		DRAWING NO.	SCALE
DECIMALS .XX ±.02 [.5mm]		SEE NOTES			0.200
FRACTIONS ±1/32 [.8 mm]		FINISH		PART NO.	SHEET OF
		SEE NOTES		RV-12PB-50	1 2

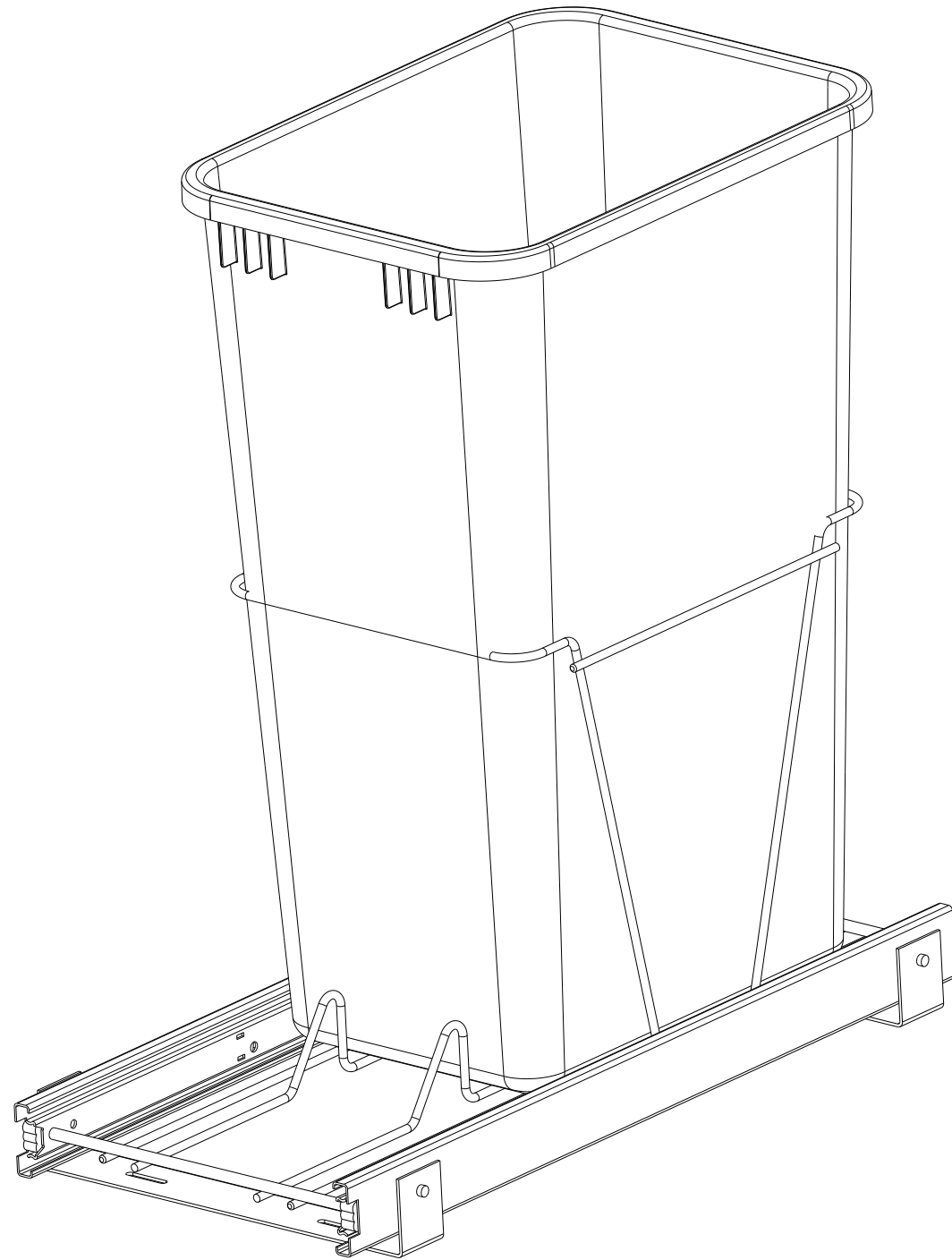

PART DIMENSIONS		
	MIN	MAX
WIDTH	11.25	
DEPTH	22.00	
HEIGHT	23.25	
WEIGHT		
DIAMETER		
RADIUS		
CONTAINER CAPACITY		
CONTAINER UOM		

MIN CABINET OPENING	
WIDTH	11.25
DEPTH	22.00
HEIGHT	23.50

PRODUCT MAX WEIGHT RATING

SLIDE SPECIFICATIONS				
SLIDE TYPE	BALL BEARING	SLIDE EXTENSION	3/4	MAX WEIGHT RATING
SLIDE CLOSING	N/A	SLIDE LENGTH	550mm	
SLIDE MOUNTING	BOTTOM	SLIDE FINISH	ZINC PLATED	100LB

FOR CUSTOMER APPROVAL DRAWING

This drawing is the property of Rev-A-Shelf (RAS) and is disclosed in confidence to the extent its subject matter is original to RAS. Any vendor receiving this drawing from RAS shall hold and use this drawing for the sole benefit of RAS and shall not disclose it to, or use or reproduce it for any third party, or perform any act adverse to the interest of RAS with respect to this drawing without the express written permission of RAS. Vendors shall not revise any physical, dimensional or performance characteristic unless authorized by Rev-A-Shelf Engineering.

REV.	DATE	BY	DESCRIPTION OF CHANGE

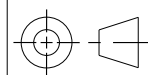
INCH [MM]	AMERICAN PROJECTION 	DRAWN	BY	DATE	REV-A-SHELF, Inc.
			KRR	3-3-23	
TOLERANCES					SIZE
DECIMALS		ANGLES		DRAWING NO.	
.XX ±.02 [.5mm]		±1/2°		SCALE	
.XXX ±.005 [.13 mm]		SEE NOTES		0.200	
FRACTIONS ±1/32 [.8 mm]		FINISH		PART NO.	
SEE NOTES		SEE NOTES		RV-12PB-50	
				SHEET OF	
				2 OF 2	