

CUSTOMER DRAWING

This drawing is the property of Rev-A-Shelf (RAS) and is disclosed in confidence to the extent its subject matter is original to RAS. Any vendor receiving this drawing from RAS shall hold and use this drawing for the sole benefit of RAS and shall not disclose it to, or use or reproduce it for any third party, or perform any act adverse to the interest of RAS with respect to this drawing without the express written permission of RAS. Vendors shall not revise any physical, dimensional or performance characteristic unless authorized by Rev-A-Shelf Engineering.

REV.	DATE	BY	DESCRIPTION OF CHANGE

INCH [MM]	AMERICAN PROJECTION 	DRAWN	BY	DATE	REV-A-SHELF, INC.
			LCS	8-3-23	
					SIZE B
					DRAWING NO. CROIBSL-14-SM-1
					SCALE 0.200
					PART NO. CROIBSL-14-SM-1
					SHEET OF 1 3
TOLERANCES		ANGLES			
MAT. DEC.		±1/2°			
(WOOD) .XX ±.03 [8mm]					
(OTHER) .XX ±.02 [5mm]					
(ALL) .XXX ±.005 [13 mm]					
FRACTIONS ±1/32 [8 mm]					

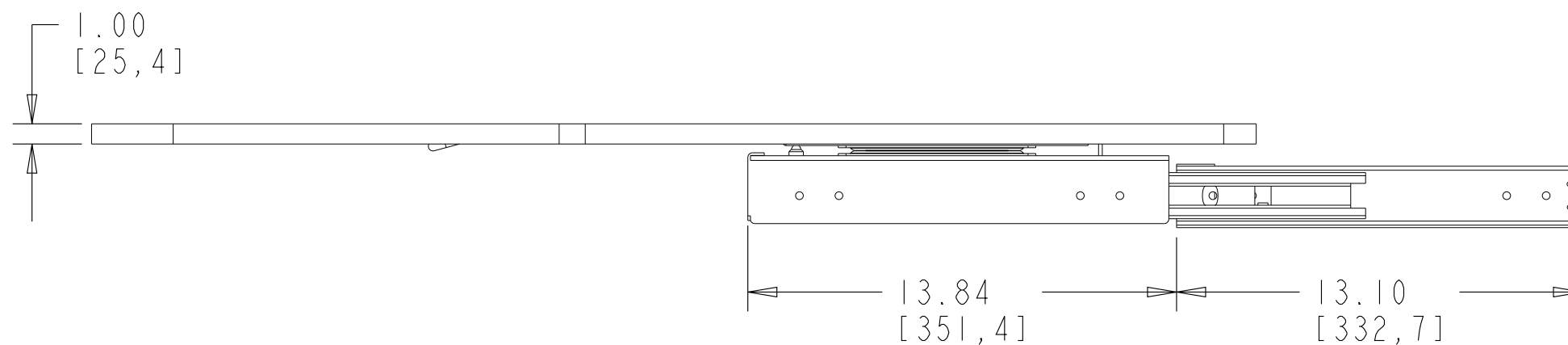
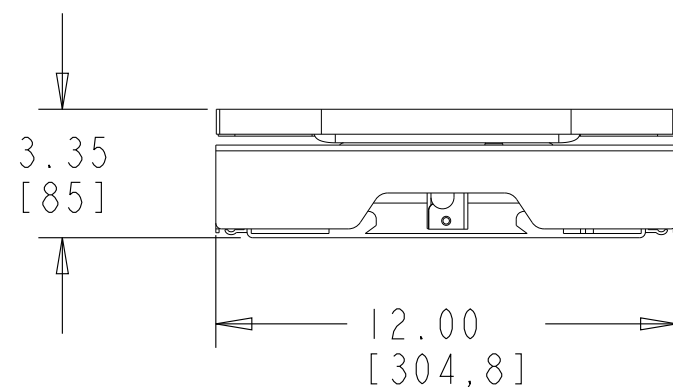
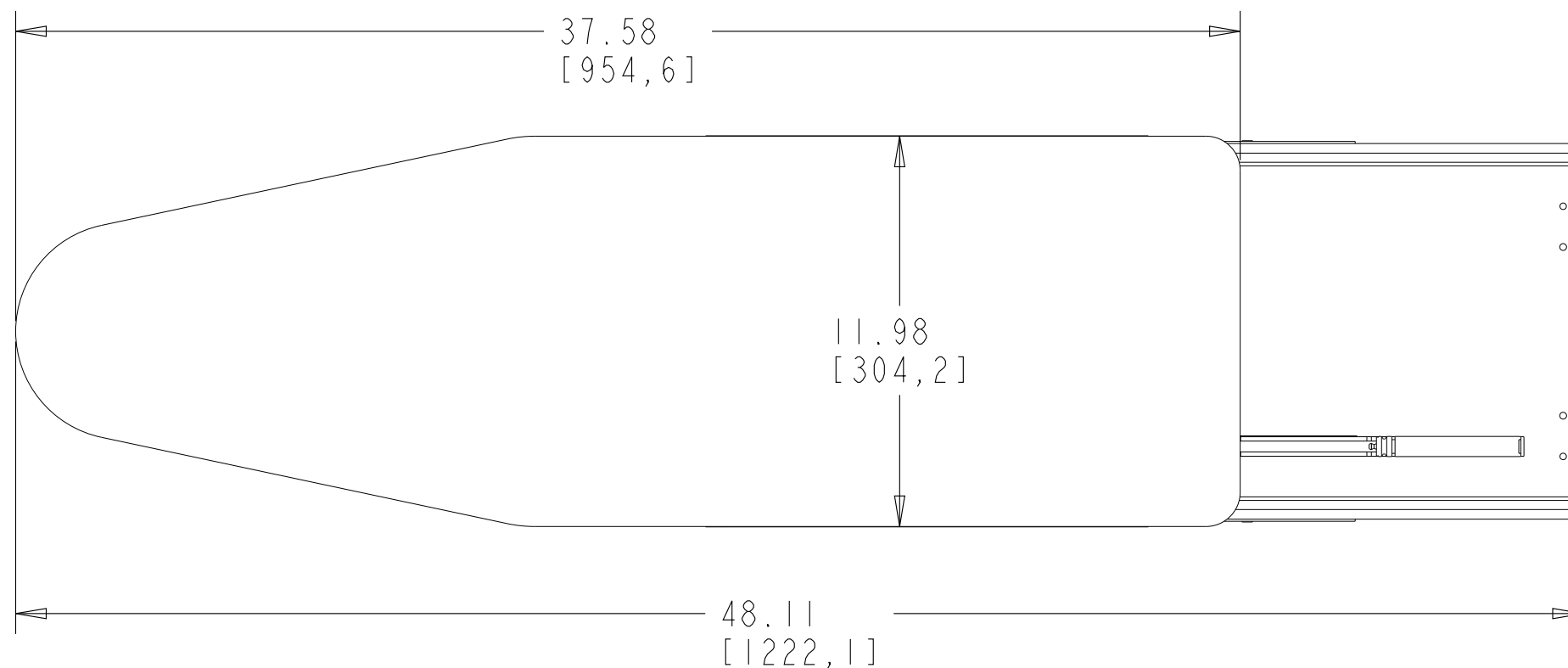

CUSTOMER DRAWING

This drawing is the property of Rev-A-Shelf (RAS) and is disclosed in confidence to the extent its subject matter is original to RAS. Any vendor receiving this drawing from RAS shall hold and use this drawing for the sole benefit of RAS and shall not disclose it to, or use or reproduce it for any third party, or perform any act adverse to the interest of RAS with respect to this drawing without the express written permission of RAS. Vendors shall not revise any physical, dimensional or performance characteristic unless authorized by Rev-A-Shelf Engineering.

REV.	DATE	BY	DESCRIPTION OF CHANGE

INCH [MM]	AMERICAN PROJECTION 	DRAWN	BY	DATE	REV-A-SHELF, Inc.
		LCS		8-3-23	
TOLERANCES		MATERIAL	DRAWING NO.		SCALE
MAT.	DEC.		CROIBSL-14-SM-1		
(WOOD)	.XX ±.03 [8mm]	FINISH	PART NO.		SHEET OF
(OTHER)	.XX ±.02 [5mm]		CROIBSL-14-SM-1		
(ALL)	.XXX ±.005 [13 mm]	ANGLES		±1/2°	
FRACTIONS	±1/32 [8 mm]				

CLOSED

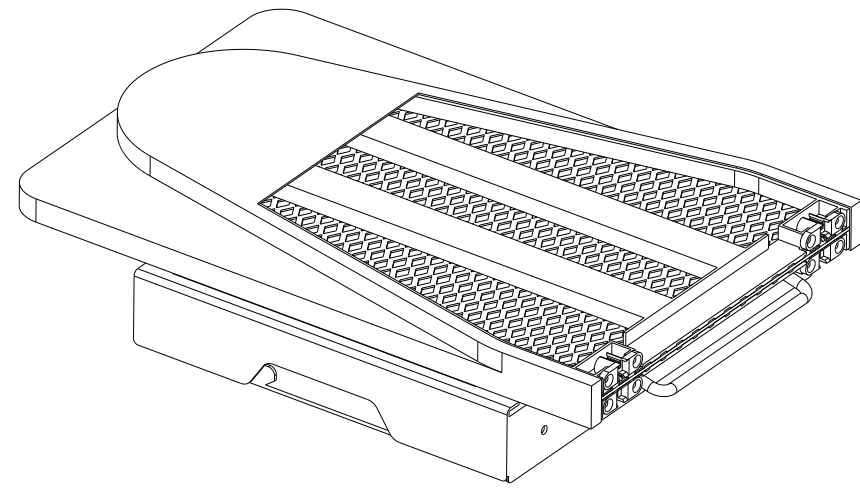

OPEN

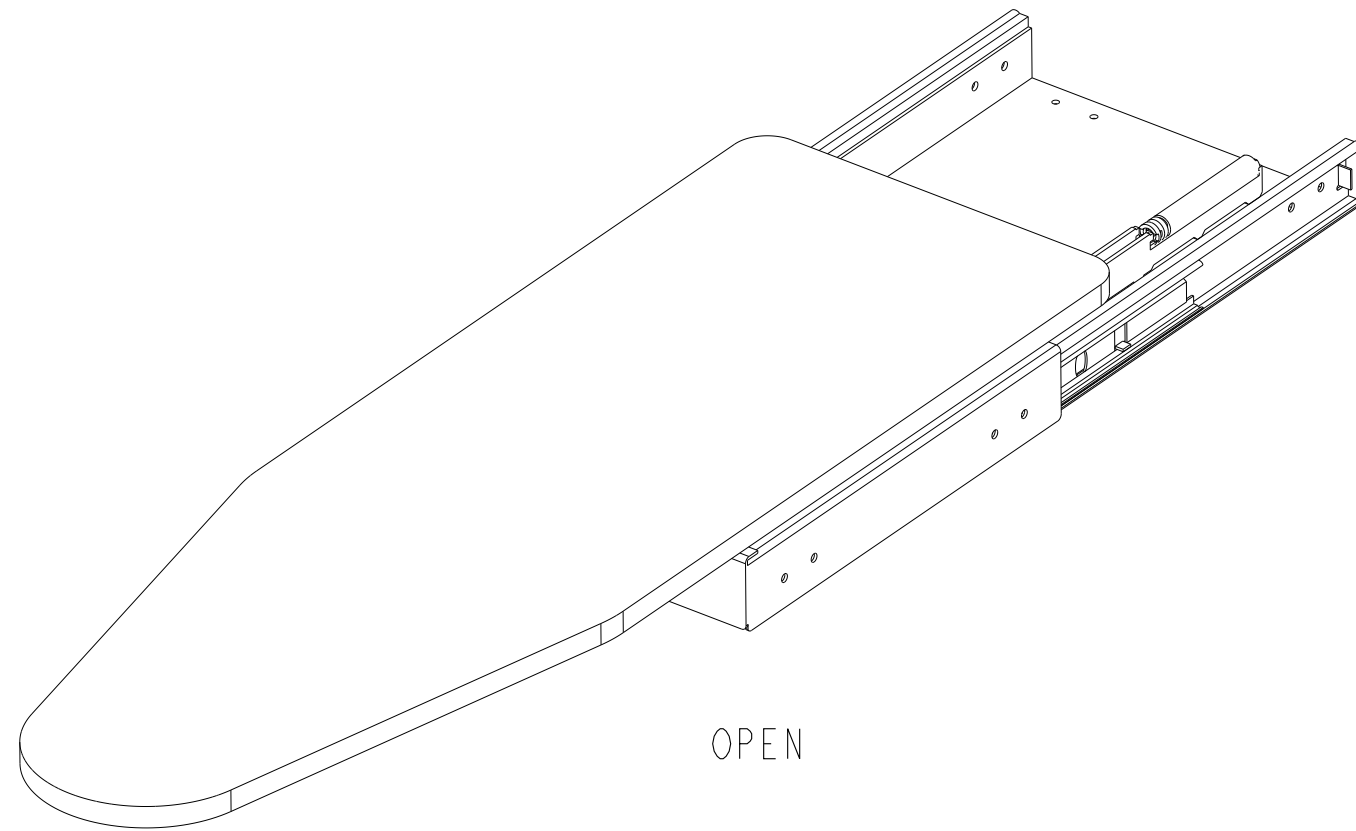

PART DIMENSIONS

WIDTH	19.45 [494]
DEPTH	13.64 [346,4]
HEIGHT	4.53 [115,1]

MIN CABINET OPENING

WIDTH	20.00 [508]
DEPTH	14.00 [355,6]
HEIGHT	5.50 [139,7]

SLIDE SPECIFICATIONS

SLIDE TYPE	BALL BEARING	SLIDE EXTENSION	OVER-TRAVEL
SLIDE CLOSING	SOFT	SLIDE LENGTH	332MM
SLIDE MOUNTING	BOTTOM	SLIDE FINISH	ZINC

CUSTOMER DRAWING

This drawing is the property of Rev-A-Shelf (RAS) and is disclosed in confidence to the extent its subject matter is original to RAS. Any vendor receiving this drawing from RAS shall hold and use this drawing for the sole benefit of RAS and shall not disclose it to, or use or reproduce it for any third party, or perform any act adverse to the interest of RAS with respect to this drawing without the express written permission of RAS. Vendors shall not revise any physical, dimensional or performance characteristic unless authorized by Rev-A-Shelf Engineering.

REV.	DATE	BY	DESCRIPTION OF CHANGE

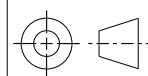
INCH [MM]	AMERICAN PROJECTION 	DRAWN	BY	DATE	REV-A-SHELF, Inc.
		LCS	LCS	8-3-23	
TOLERANCES		ANGLES ±1/2°	MATERIAL	DRAWING NO.	SCALE
MAT.	DEC.		FINISH	CROIBSL-14-SM-1	0.167
(WOOD)	.XX ±.03 [.8mm]			PART NO.	SHEET
(OTHER)	.XX ±.02 [.5mm]			CROIBSL-14-SM-1	3 OF 3
(ALL)	.XXX ±.005 [.13 mm]				
FRACTIONS	±1/32 [.8 mm]				