

SONDER

LIVING

EMERSON DINING TABLE

Thank you for choosing this quality product. Be sure to check all packaging materials carefully for small parts that may have become loose during shipment and place all parts on a non-abrasive surface.

IMPORTANT :These parts can be cumbersome and heavy to some people, therefore the assistance of two or more people is recommended in order to prevent personal injury and ensure the furniture is not damaged during the assembly Process.

CARE INSTRUCTIONS

1. Dust often using a clean, soft, dry and lint-free cloth.
2. Blot spills immediately and wipe with a clean, damp, cloth.
3. We do not recommend the use of chemical cleansers, abrasives or furniture polish on our lacquered finish.

IMPORTANT SAFETY INSTRUCTIONS

1. Please read all instructions carefully before assembling.
2. For your safety, assembly by two or more adults is strongly recommended.
3. Keep instructions for future use.
4. Use only vendor supplied hardware to assemble. Using unauthorized hardware could jeopardize the structural integrity of the item.

PART LIST

A [1] TABLETOP





B [1] EXTENDER SHELF

C [1] BASE

INSTRUCTIONS

1. Gently, lay the table top (A) upside down on a soft flat surface. Attach the table base into the table top, align and insert Allen bolt (1) together with lock washer (2) and flat washer (3) to each fixed nuts under top through the hole on the top of the base. Tighten all the bolts by using wrench (4). **DO NOT OVERTIGHTEN**. See **FIGURE 01**.
2. After assembly, turn the table upright on a flat surface.

HARDWARE LIST

NO	DESCRIPTION	QTY
1	 ALLEN HEAD BOLT M8x45MM	8
2	 LOCK WASHER	8
3	 PLAIN WASHER	8
4	 ALLEN WRENCH	1

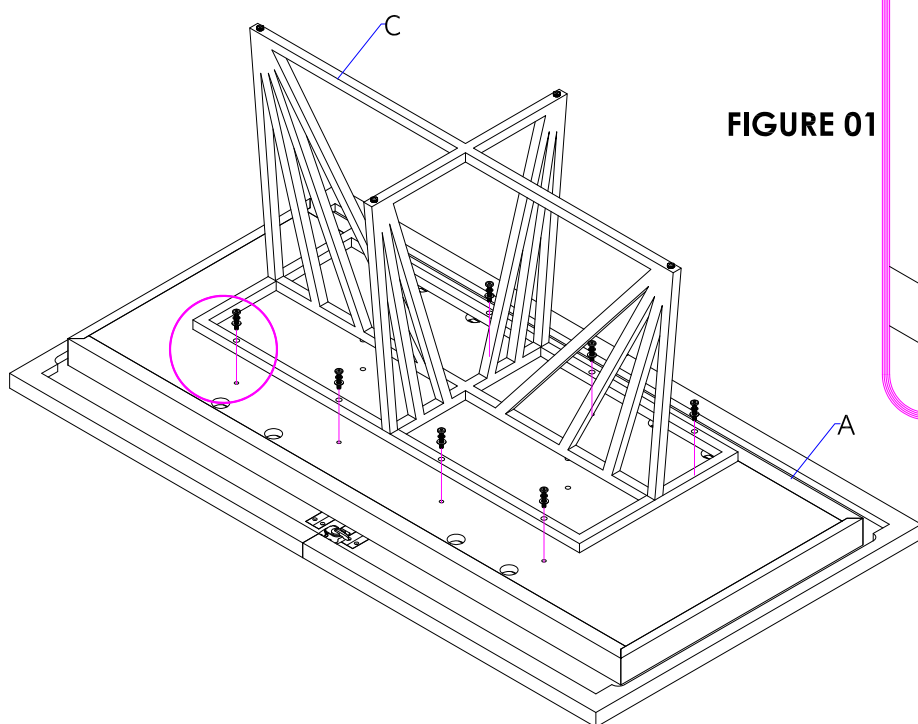
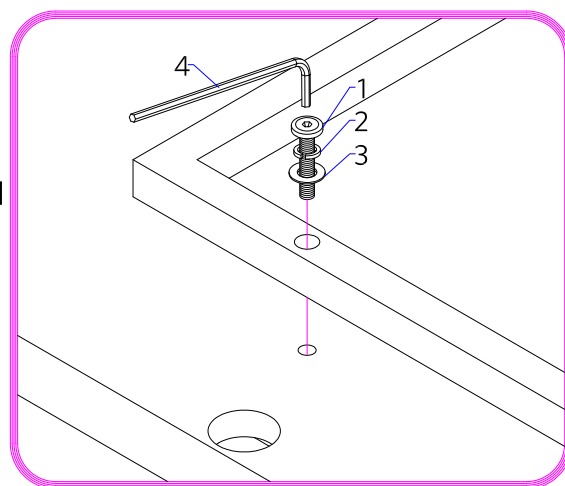

FIGURE 01



3. Unlock the locker under Table top , open the top panel, put the Extender shelf (B) at the middle of table top. Make sure the exposed tennon on the side edge of panels align with pre-drilled holes on the side edge of panels. Close top panels and clock the lockers under Table top. See FIGURE 02 & 03.
4. Check the table leveling, and adjust the levelers at the bottom of the base if necessary. See FIGURE 04.

FIGURE 02

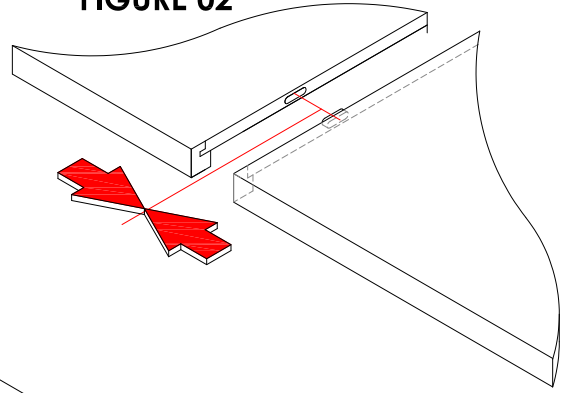

FIGURE 03

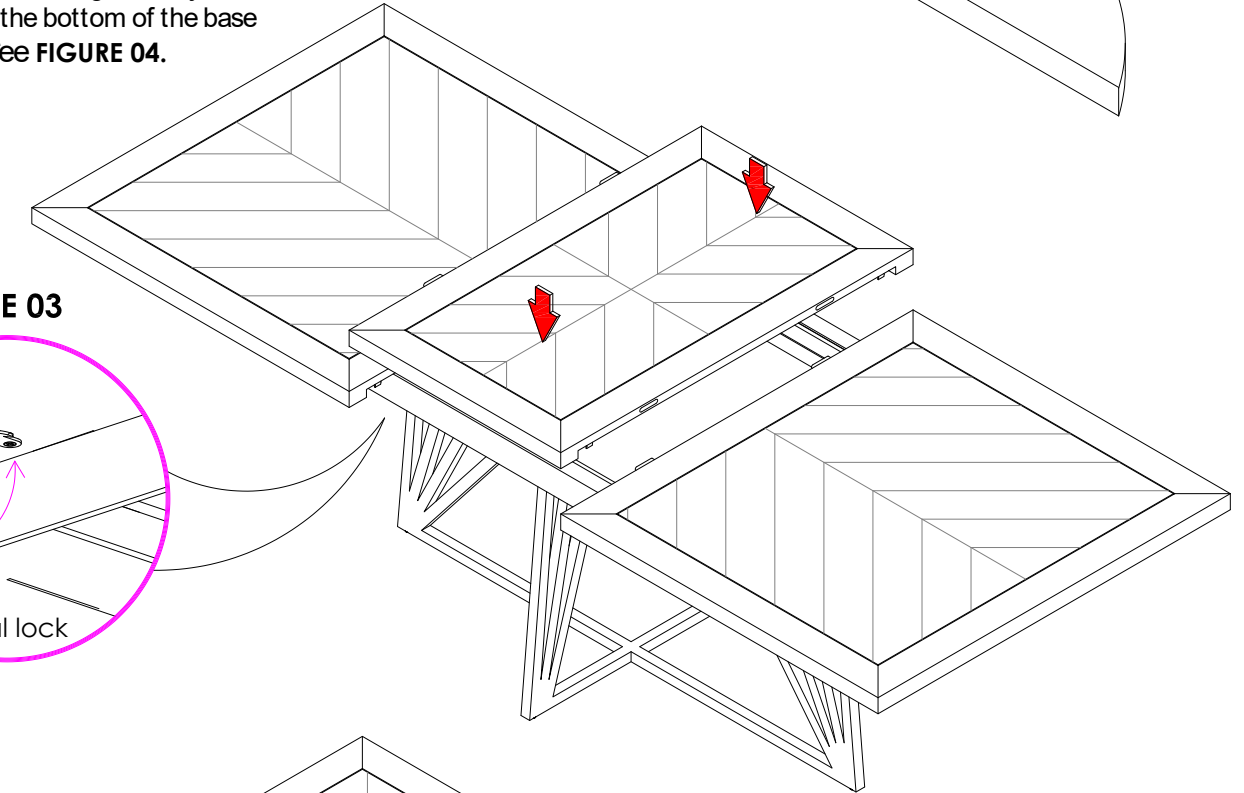
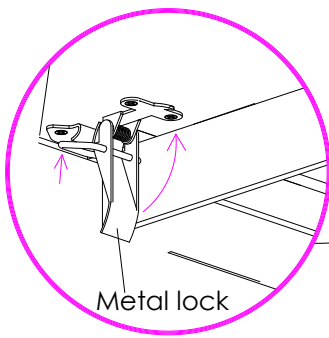
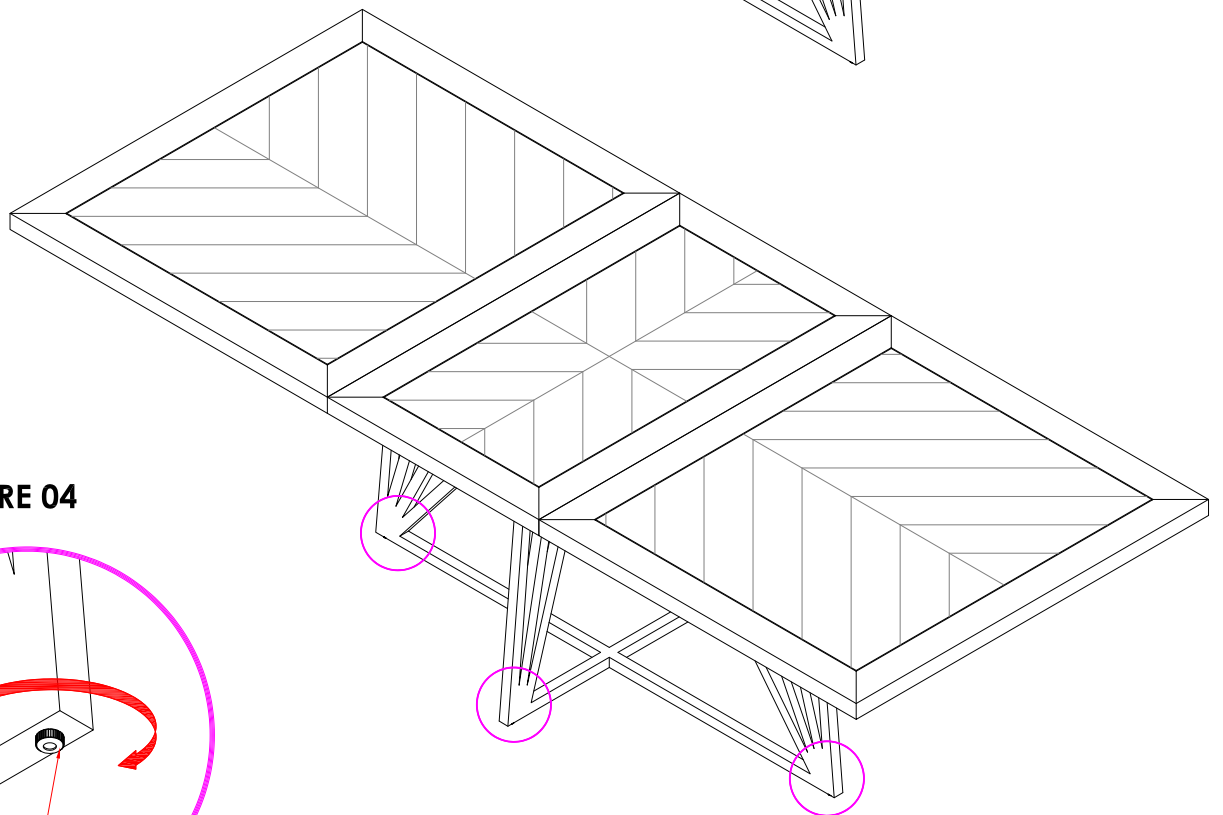
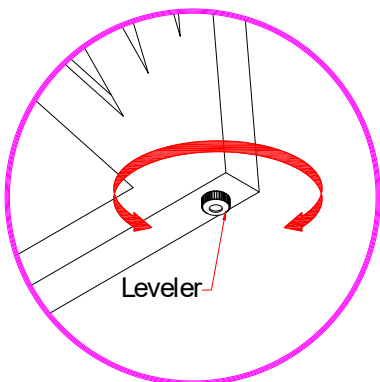

FIGURE 04



EXTENDER SHELF COMPARTMENT

1. Unlock the locker under Table top , open the top panel and remove the Extender shelf from the Table top. See FIGURE 05.
2. Gently tilt the Extender shelf and put it into the inside of the box frame installed underneath of the table top. See FIGURE 06.
3. Once the Extender shelf is set. Close the table top and lock the locker under table top. See FIGURE 07.

FIGURE 05

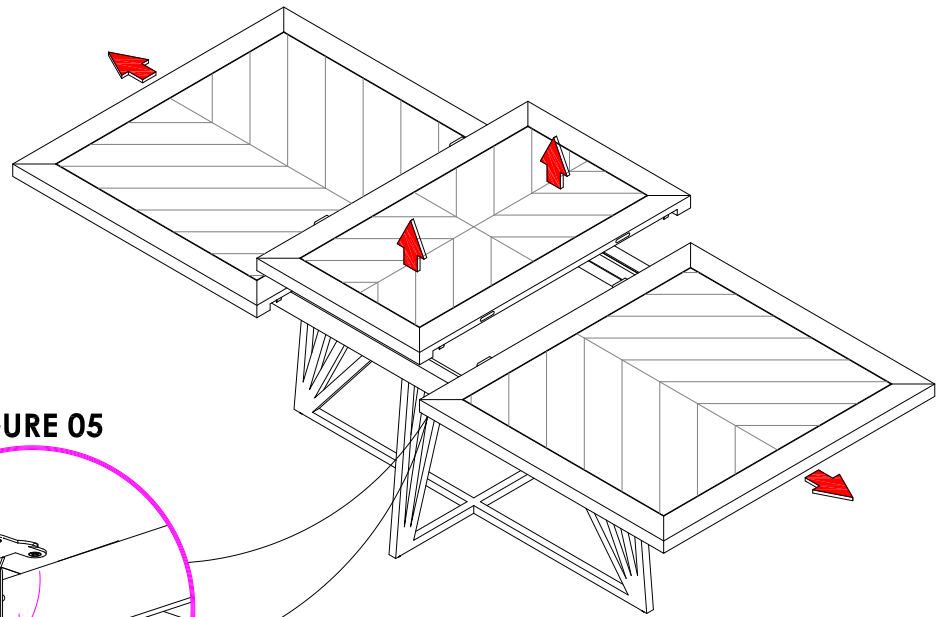
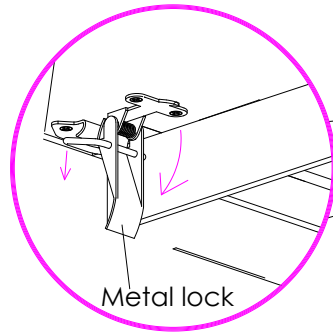

FIGURE 06

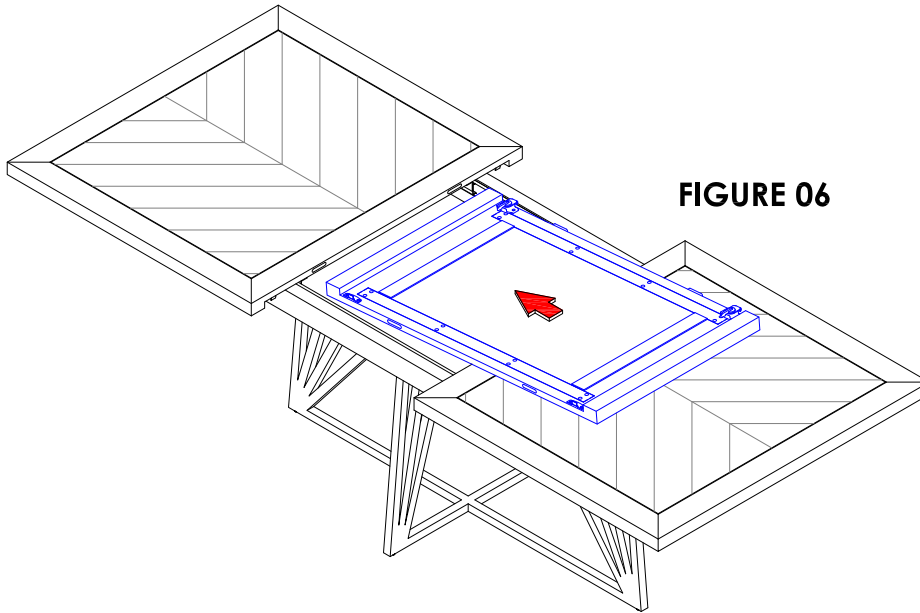

FIGURE 07

