

NOTES:  
 1. RECOMMENDED SCREW SIZE INTO DOOR #6X 1/2" (PROVIDED BY RAS)  
 QTY 6

CUSTOMER DRAWING

This drawing is the property of Rev-A-Shelf (RAS) and is disclosed in confidence to the extent its subject matter is original to RAS. Any vendor receiving this drawing from RAS shall hold and use this drawing for the sole benefit of RAS and shall not disclose it to, or use or reproduce it for any third party, or perform any act adverse to the interest of RAS with respect to this drawing without the express written permission of RAS. Vendors shall not revise any physical, dimensional or performance characteristic unless authorized by Rev-A-Shelf Engineering.

REV.	DATE	BY	DESCRIPTION OF CHANGE
B	6/21/23	BKT	ECN23-057
A	12/7/21	BKT	ECN21-059

INCH [MM]	AMERICAN PROJECTION 	BY	DATE	REV-A-SHELF, INC.	
		BKT	12/7/21		
		DRAWN		SIZE	5" WOOD PANTRY
		TOLERANCES		MATERIAL	DRAWING NO.
		MAT. DEC. (WOOD) .XX ±.03 [.8mm] (OTHER) .XX ±.02 [.5mm] (ALL) .XXX ±.005 [.13 mm] FRACTIONS ±1/32 [.8 mm]		FINISH	448-TPF58-5-1
		ANGLES ±1/2°		PART NO.	SCALE
				448-TPF58-5-1	0.150
					SHEET OF
					1 OF 2

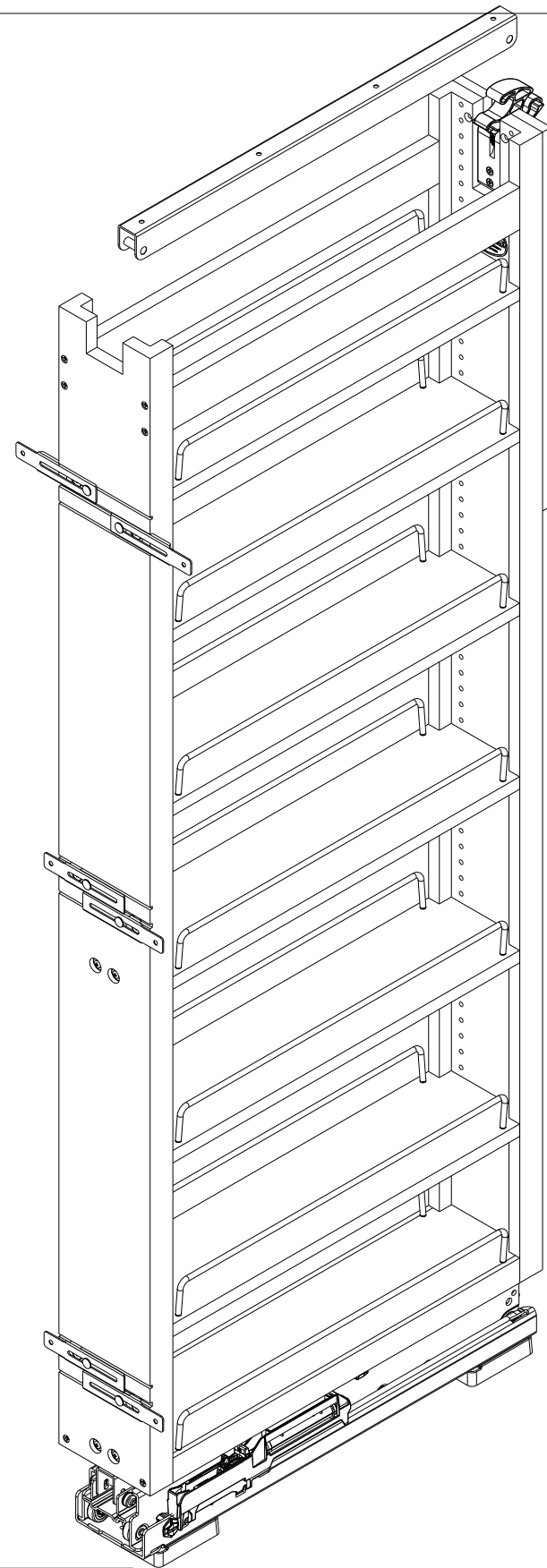

MIN CABINET OPENING	
WIDTH	5.50
DEPTH	20.50
HEIGHT	58.50

PRODUCT MAX WEIGHT RATING
BHMA STANDARD

SLIDE SPECIFICATIONS				
SLIDE TYPE	HEAVY DUTY	SLIDE EXTENSION	527MM	MAX WEIGHT RATING
SLIDE CLOSING	SOFT CLOSE	SLIDE LENGTH	546MM	
SLIDE MOUNTING	FLOOR	SLIDE FINISH	METALIC GRAY	

CUSTOMER DRAWING

This drawing is the property of Rev-A-Shelf (RAS) and is disclosed in confidence to the extent its subject matter is original to RAS. Any vendor receiving this drawing from RAS shall hold and use this drawing for the sole benefit of RAS and shall not disclose it to, or use or reproduce it for any third party, or perform any act adverse to the interest of RAS with respect to this drawing without the express written permission of RAS. Vendors shall not revise any physical, dimensional or performance characteristic unless authorized by Rev-A-Shelf Engineering.

REV.	DATE	BY	DESCRIPTION OF CHANGE
B	6/21/23	BKT	ECN23-057
A	12/7/21	BKT	ECN21-059

INCH [MM]	AMERICAN PROJECTION 	DRAWN	BY	DATE	REV-A-SHELF, INC.
			BKT	12/7/21	
					SIZE <b>B</b>
					5" WOOD PANTRY
TOLERANCES MAT. DEC. (WOOD) .XX ±.03 [.8mm] (OTHER) .XX ±.02 [.5mm] (ALL) .XXX ±.005 [.13 mm] FRACTIONS ±1/32 [.8 mm]			ANGLES ±1/2°	MATERIAL	DRAWING NO. 448-TPF58-5-1
			FINISH	PART NO. 448-TPF58-5-1	SCALE 0.150
					SHEET OF 2 OF 2