

CUSTOMER DRAWING

This drawing is the property of Rev-A-Shelf (RAS) and is disclosed in confidence to the extent its subject matter is original to RAS. Any vendor receiving this drawing from RAS shall hold and use this drawing for the sole benefit of RAS and shall not disclose it to, or use or reproduce it for any third party, or perform any act adverse to the interest of RAS with respect to this drawing without the express written permission of RAS. Vendors shall not revise any physical, dimensional or performance characteristic unless authorized by Rev-A-Shelf Engineering.

REV.	DATE	BY	DESCRIPTION OF CHANGE

INCH [MM]	AMERICAN PROJECTION 	BY	DATE	REV-A-SHELF, INC.
		BKT	4/04/14	
TOLERANCES		MATERIAL	DRAWING NO.	SCALE
MAT.	DEC.		438-BC-3C	
(WOOD)	.XX ±.03 [.8mm]	FINISH	PART NO.	SHEET OF
(OTHER)	.XX ±.02 [.5mm]		438-BC-3C	
(ALL)	.XXX ±.005 [.13 mm]			
	FRACTIONS ±1/32 [.8 mm]			

SLIDE SPECIFICATIONS				
SLIDE TYPE	BALL BEARING	SLIDE EXTENSION	FULL	MAX WEIGHT RATING
SLIDE CLOSING	N/A	SLIDE LENGTH	550MM	
SLIDE MOUNTING	TOP/BOTTOM	SLIDE FINISH	ZINC	100 LB

PART DIMENSIONS		
	MIN	MAX
WIDTH	3.00 [76,2]	
DEPTH	23.00 [584,2]	
HEIGHT	26.38 [670] CUT DOWN MINIMUM	27.31 [693,7] NOT CUT DOWN

MIN CABINET OPENING	
WIDTH	3.00 [76,2]
DEPTH	23.00 [584,2]
MIN. HEIGHT CUT DOWN	26.38 [670]
HEIGHT NOT CUT DOWN	27.31 [693,7]

PRODUCT MAX WEIGHT RATING
BMHA STANARDS

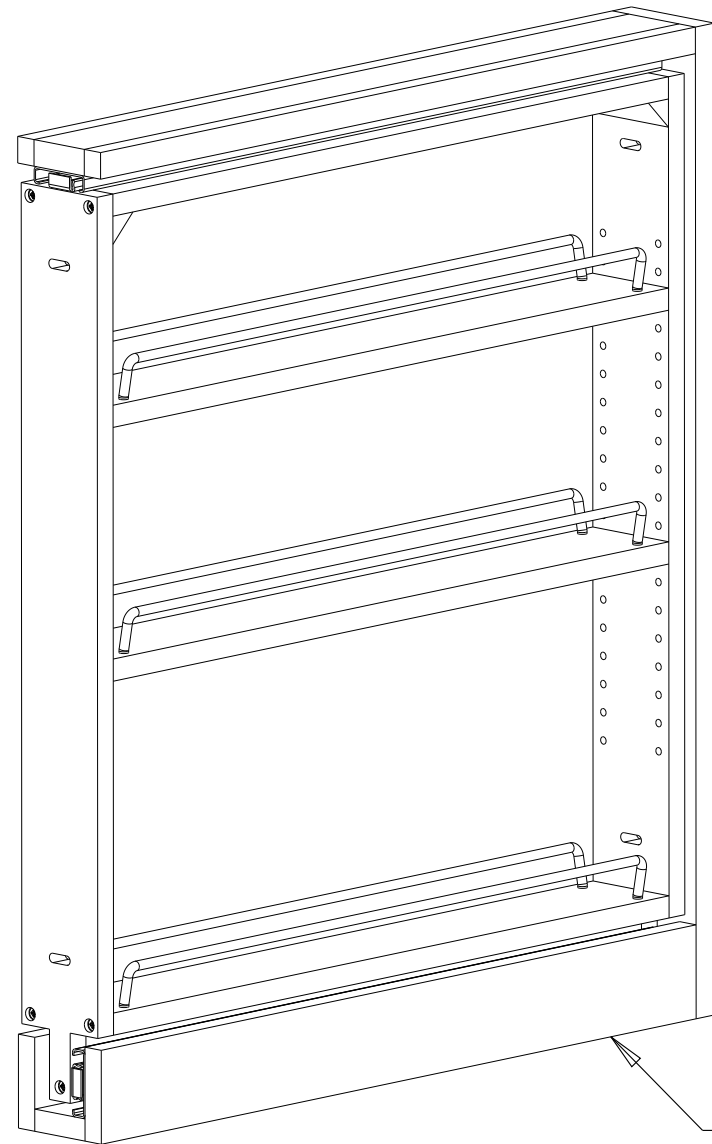

UNIT MAY NEED TO BE CUT DOWN TO FIT CABINET OPENING (CUT DOWN AT BOTTOM ONLY)
THIS UNIT SHOWN CUT-DOWN TO MINIMUM HEIGHT.

CUSTOMER DRAWING

This drawing is the property of Rev-A-Shelf (RAS) and is disclosed in confidence to the extent its subject matter is original to RAS. Any vendor receiving this drawing from RAS shall hold and use this drawing for the sole benefit of RAS and shall not disclose it to, or use or reproduce it for any third party, or perform any act adverse to the interest of RAS with respect to this drawing without the express written permission of RAS. Vendors shall not revise any physical, dimensional or performance characteristic unless authorized by Rev-A-Shelf Engineering.

REV.	DATE	BY	DESCRIPTION OF CHANGE

INCH [MM]	AMERICAN PROJECTION	DRAWN	BY	DATE	REV-A-SHELF, INC.
			BKT	4/04/14	
			SIZE	3" BASE ORGANIZER PULLOUT 438	
			MATERIAL	DRAWING NO.	SCALE
			FINISH	438-BC-3C	0.200
				PART NO.	438-BC-3C

TOLERANCES
 MAT. DEC.
 (WOOD) .XX ±.03 [.8mm]
 (OTHER) .XX ±.02 [.5mm]
 (ALL) .XXX ±.005 [.13 mm]
 FRACTIONS ±1/32 [.8 mm]

ANGLES
 ±1/2°