

Lumination® LED Luminaire

ProLine® Strip Fixture Series

(PSF-Series)



BEFORE YOU BEGIN

Read these instructions completely and carefully.

⚠ WARNING/AVERTISSEMENT

RISK OF ELECTRIC SHOCK

- Turn power off before inspection, installation or removal.
- Properly ground electrical enclosure.

RISK OF ELECTRIC SHOCK

- Follow all NEC and local codes.
- Use only UI approved wire for input/output connections. Minimum size 18 AWG (0.75mm²).
- Do not install insulation within 3 inches (76 mm) of luminaire top.

RISQUES DE DÉCHARGES ÉLECTRIQUES

- Coupez l'alimentation avant d'inspecter, installer ou déplacer le luminaire.
- Assurez-vous de correctement mettre à la terre le boîtier d'alimentation électrique.

RISQUES D' INCENDIE

- Respectez tous les codes NEC et codes locaux.
- N'utilisez que des fils approuvés par UL pour les entrées/sorties de connexion. Taille minimum 18 AWG (0.75mm²).
- Maintenir une distance de 76 mm (3 pouces) entre le luminaire et l'isolant.

Save These Instructions

Use only in the manner intended by the manufacturer. If you have any questions, contact the manufacturer.

This device complies with Part 15 of the FCC Rules. Operation is subject to the following two conditions: (1) This device may not cause harmful interference, and (2) this device must accept any interference received, including interference that may cause undesired operation. CAN ICES-005(A)/NMB-005(A)

Note: This equipment has been tested and found to comply with the limits for a Class A digital device, pursuant to part 15 of the FCC Rules. These limits are designed to provide reasonable protection against harmful interference when the equipment is operated in a commercial environment. This equipment generates, uses, and can radiate radio frequency energy and, if not installed and used in accordance with the instruction manual, may cause harmful interference to radio communications. Operation of this equipment in a residential area is likely to cause harmful interference in which case the user will be required to correct the interference at his own expense.

Prepare Electrical Wiring



Electrical Requirements

- The LED luminaire must be connected to the mains supply according to its ratings on the product label.
- Class 1 wiring should be in accordance with NEC.



Grounding Instructions

- The grounding and bonding of the overall system shall be done in accordance to local electric code of the country where the luminaire is installed.

Installation

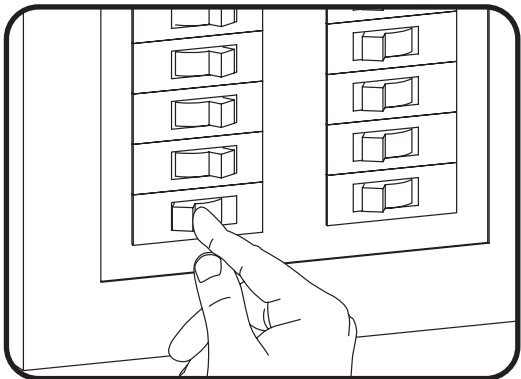

1 For safety, turn off main power prior to installation.

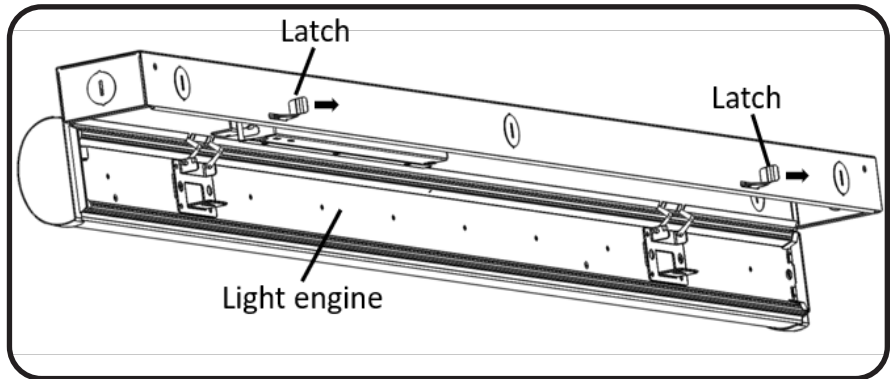

2 Release latches on the side of the fixture. Carefully pull down the light engine from latch side. Set desired Power/CCT as following with screwdriver.

POWER	H/M (Default)/L
CCT	3500K/4000K (Default)/5000K

Mounting Options

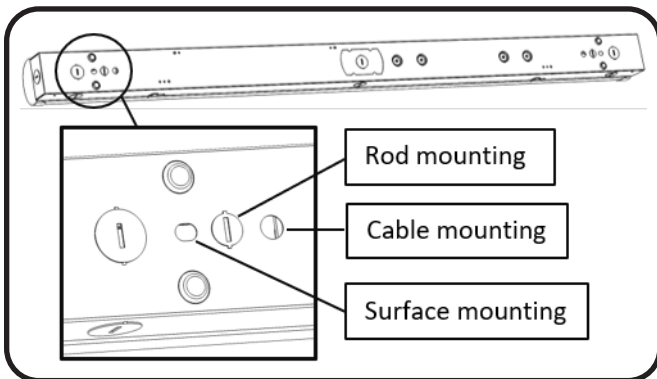

Three mounting options available

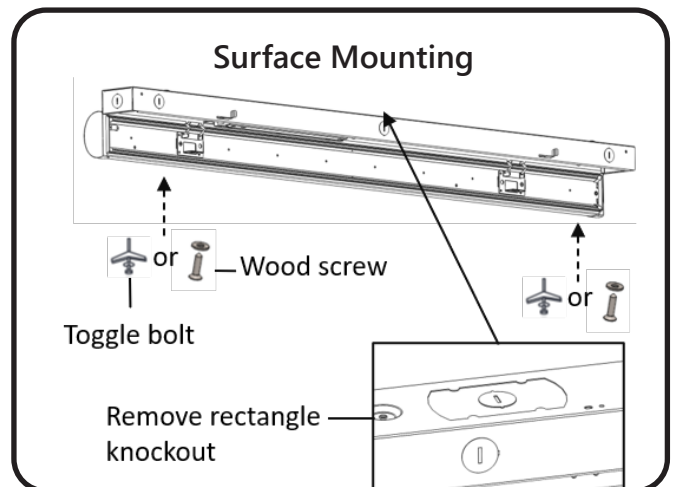
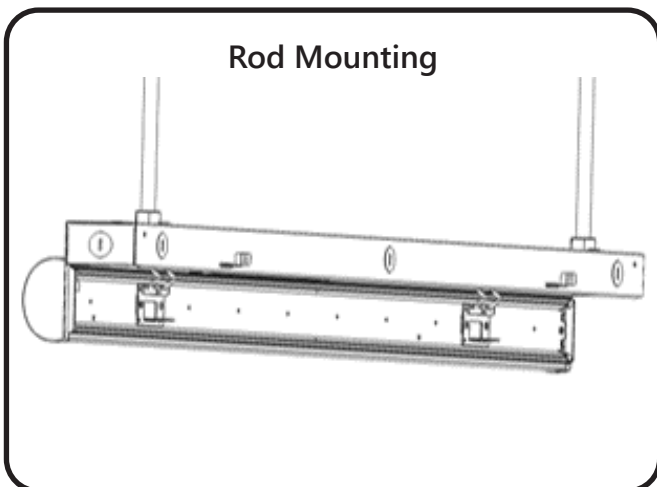
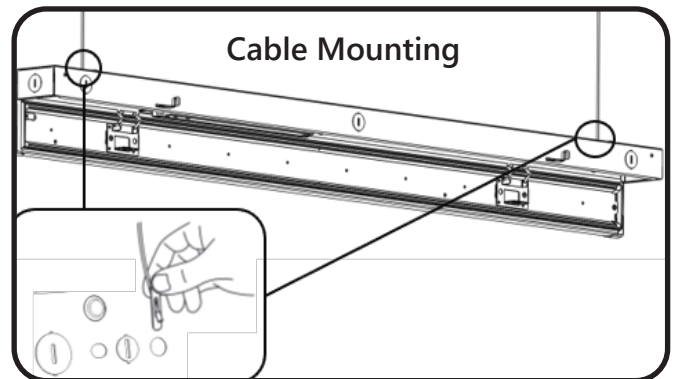

TOGGLE/CABLE (ORDER SEPARATELY)	DESCRIPTION	PRODUCT ORDER CODE
Toggle/Suspension Cable 5'	CABLE HANGER,GRIFFLE,XP2TG-5FT300MMPAIR	PRT0202
Toggle/Suspension Cable 10'	CABLE HANGER,GRIFFLE,XP2TG-10FT300MMPAIR	PRT0203
Toggle/Suspension Cable 15'	CABLE HANGER,GRIFFLE,XP2TG-15FT300MMPAIR	PRT0204

- 3** Hang fixture using cables(order separately), rods(not included) or mount directly to ceiling using appropriate hardware (not included).
Cable Mounting: Cable length shall not exceed 15ft, suitable for min. 20lbs load. Hang a pair of cables from the ceiling and pass both paddles through slots on top of fixture.
Rod Mounting: Rod length shall not exceed 15ft, suitable for min. 20lbs load.. Secure two 1/2" threaded rods into structural members in ceiling. Place a nut on each threaded rod where fixture should hang. Slide fixture onto threaded rods and tighten second nut onto rods to secure fixture.
Surface Mounting: Remove the rectangle knockout in the middle of housing, then install fixture to intended surface using mounting holes on both ends of fixture with appropriate mounting hardware. If mounting into a joist, use 2 wood screws and 2 washers to attach to joist. If joist is not available, use 2 toggle bolts and 2 washers to attach to plasterboard. Make sure the mounting surface can support the weight of the fixture.

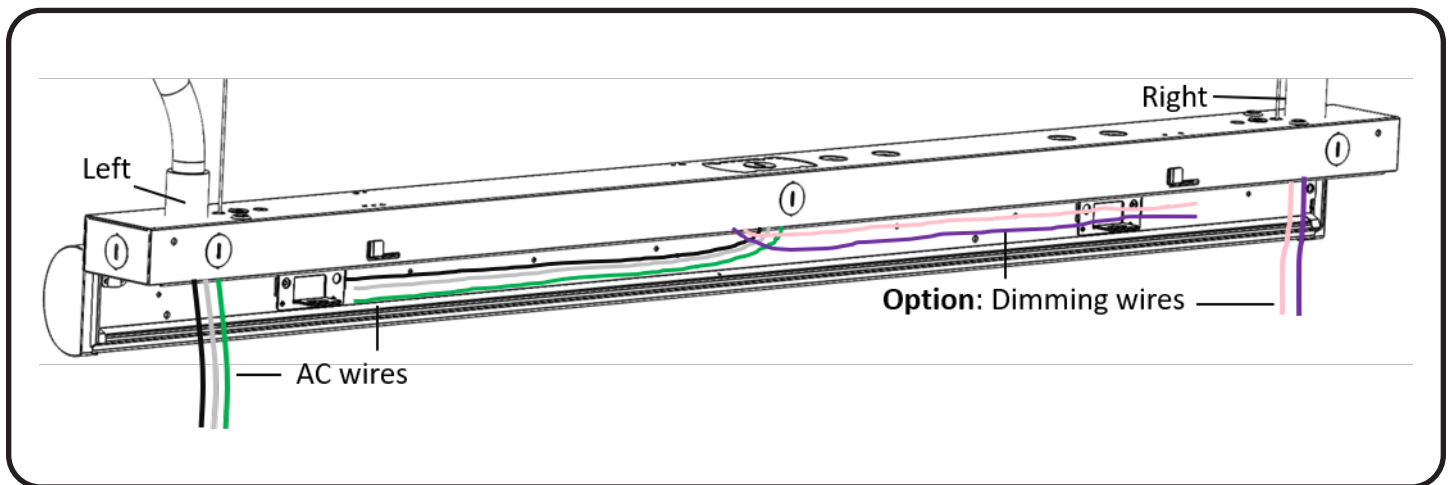

- 4-1 For Cable/Rod Mounting**
 Install conduit fitting on the knockout at left, or right, and feed the AC wires through the fitting.
Option: Install conduit fitting on the separate knockout against AC wires and feed the Dimming wires through the fitting.

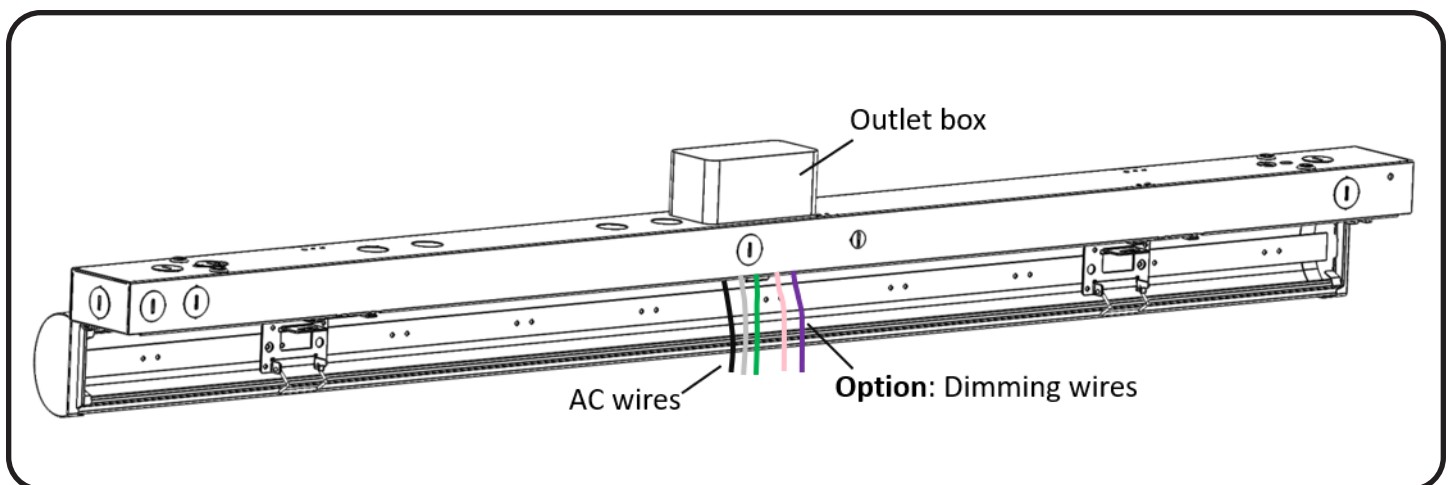

- 4-2 For Surface Mounting**
 Outlet box width shall not exceed 2in.
 Pull out AC wires, Dimming wires(Optional) to the fixture

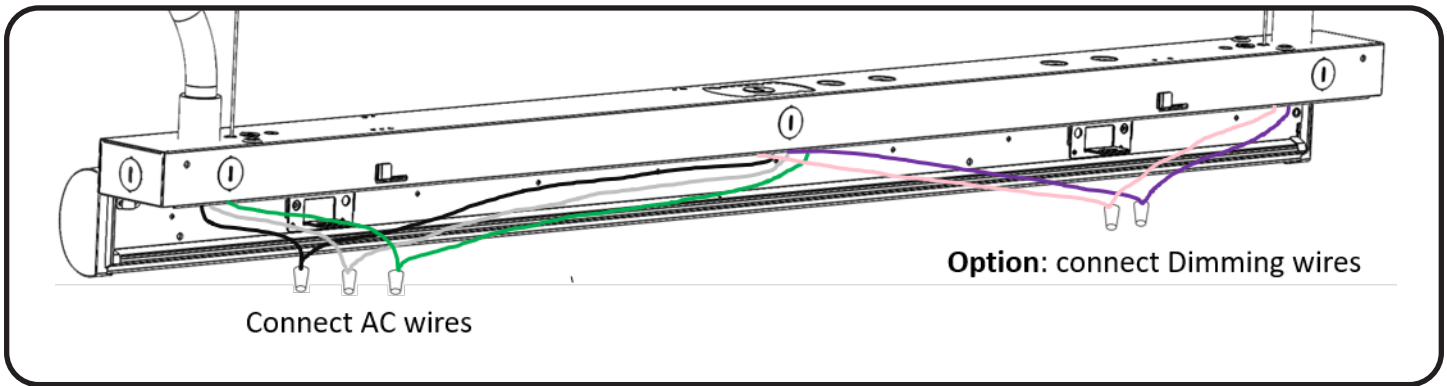

5-1 For Cable/Rod Mounting, refer to wiring diagram in final page.
 Connect the AC wires to the black (line) and white (neutral) input wires of the LED driver using UL listed wire connectors. Connect the ground wire to the green grounding wire
Option: Connect the Dimming wire (violet/pink) using UL listed wire connectors.

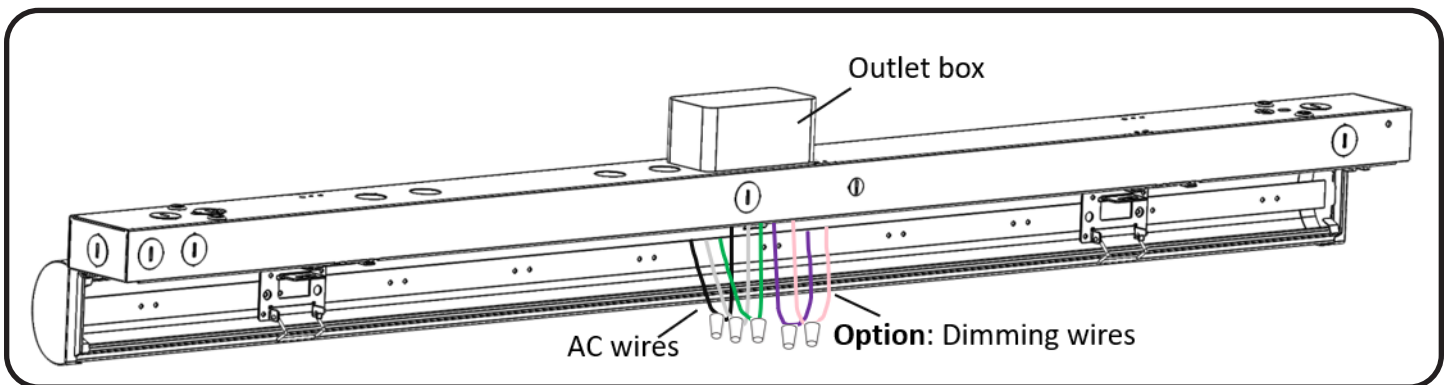

5-2 For Surface Mounting, refer to wiring diagram in final page.
 Connect the AC wires to the black (line) and white (neutral) input wires of the LED driver using UL listed wire connectors. Connect the ground wire to the green grounding wire.
Option: Connect the Dimming wire (violet/pink) using UL listed wire connectors.

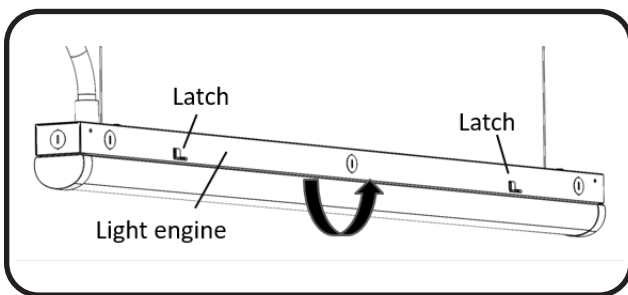

6 Rotate and replace the light engine and push back the latches.

Wiring diagram

