

This drawing is the property of Rev-A-Shelf (RAS) and is disclosed in confidence to the extent its subject matter is original to RAS. Any vendor receiving this drawing from RAS shall hold and use this drawing for the sole benefit of RAS and shall not disclose it to, or use or reproduce it for any third party, or perform any act adverse to the interest of RAS with respect to this drawing without the express written permission of RAS. Vendors shall not revise any physical, dimensional or performance characteristic unless authorized by Rev-A-Shelf Engineering.

REV.	DATE	BY	DESCRIPTION OF CHANGE
A	12/17/21	BKT	ECN21-062

INCH [MM]	AMERICAN PROJECTION 	BY	DATE	REV-A-SHELF, INC. SIZE B 10" BLUM 449 SIDE MOUNT FRAMELESS BASE PULLOUT	
		DRAWN	BKT 4/19/18		
TOLERANCES MAT. DEC. (WOOD) .XX ±.03 [.8mm] (OTHER) .XX ±.02 [.5mm] (ALL) .XXX ±.005 [.13 mm] FRACTIONS ±1/32 [.8 mm]		ANGLES ±1/2°	MATERIAL	DRAWING NO. 449-BCSC-10C_CUST	SCALE 0.188
		FINISH	PART NO. 449-BCSC-10C	SHEET OF 1 2	

CUSTOMER DRAWING

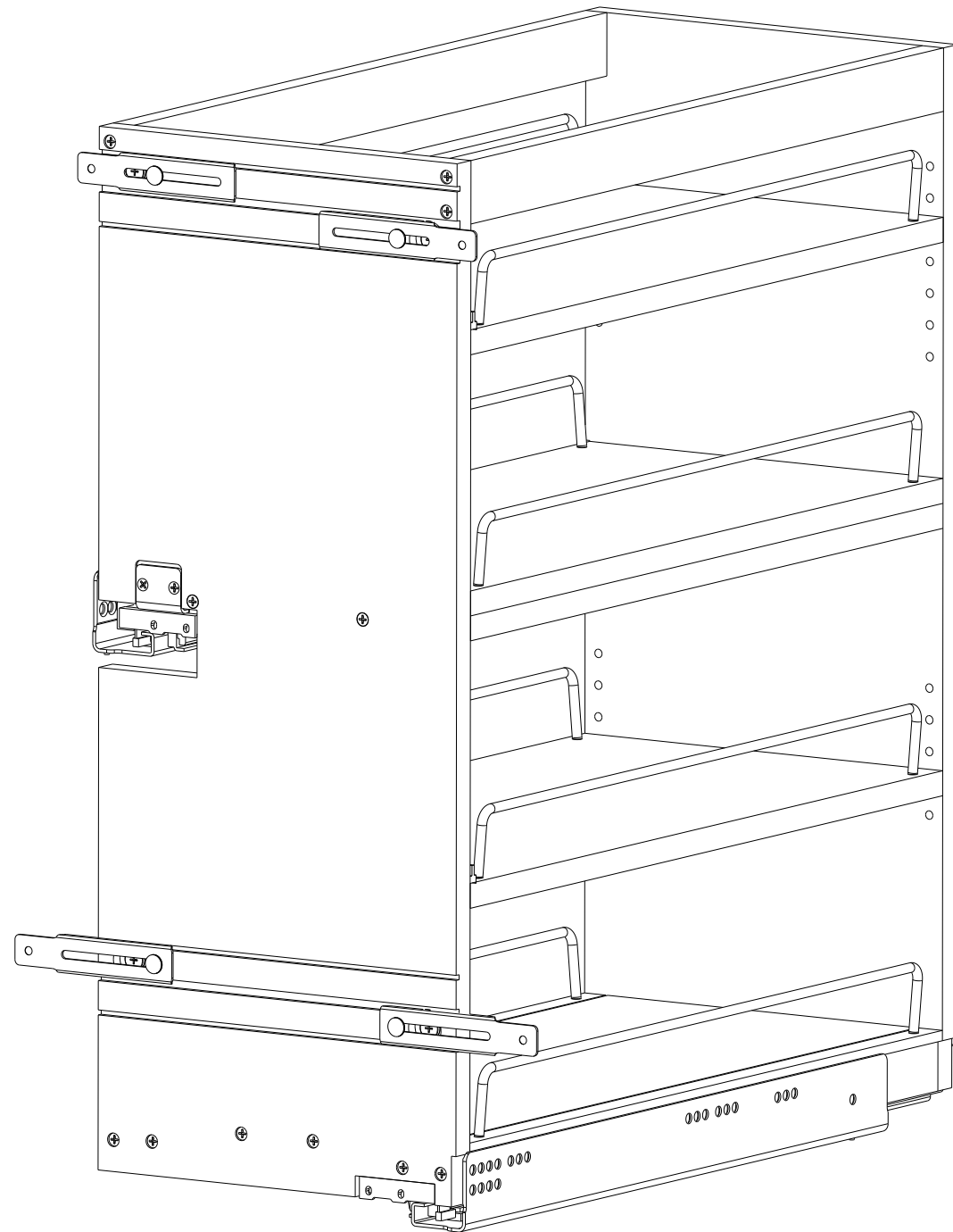

PART DIMENSIONS	
WIDTH	10.43 [265]
DEPTH	21.75 [552,5]
HEIGHT	25.25 [641,4]

MIN CABINET OPENING				
	FACE FRAME	FRAMELESS	INSET FACE FRAME	INSET FRAMELESS
WIDTH	10.50 [266,7]	10.50 [266,7]	10.50 [266,7]	10.50 [266,7]
DEPTH	21.75 [552,5]	21.75 [552,5]	22.50 [571,5]	22.50 [571,5]
HEIGHT	25.50 [647,7]	25.50 [647,7]	25.50 [647,7]	25.50 [647,7]

SLIDE SPECIFICATIONS				
SLIDE TYPE	BLUM UNDERMOUNT	SLIDE EXTENSION	FULL	MAX WEIGHT RATING
SLIDE CLOSING	SOFT CLOSE	SLIDE LENGTH	21.65 [550]	
SLIDE MOUNTING	SIDE	SLIDE FINISH	ZINC	150 LBS

CUSTOMER DRAWING

This drawing is the property of Rev-A-Shelf (RAS) and is disclosed in confidence to the extent its subject matter is original to RAS. Any vendor receiving this drawing from RAS shall hold and use this drawing for the sole benefit of RAS and shall not disclose it to, or use or reproduce it for any third party, or perform any act adverse to the interest of RAS with respect to this drawing without the express written permission of RAS. Vendors shall not revise any physical, dimensional or performance characteristic unless authorized by Rev-A-Shelf Engineering.

REV.	DATE	BY	DESCRIPTION OF CHANGE
A	12/17/21	BKT	ECN21-062

INCH [MM]	AMERICAN PROJECTION 	DRAWN	BY	DATE	REV-A-SHELF, Inc.
			BKT	4/19/18	
					SIZE
					B
					10" BLUM 449 SIDE MOUNT FRAMELESS BASE PULLOUT
					DRAWING NO.
					449-BCSC-10C_CUST
					SCALE
					0.250
					FINISH
					PART NO.
					449-BCSC-10C
					SHEET
					2 OF 2

TOLERANCES  
 MAT. DEC.  
 (WOOD) .XX ±.03 [.8mm]  
 (OTHER) .XX ±.02 [.5mm]  
 (ALL) .XXX ±.005 [.13 mm]  
 FRACTIONS ±1/32 [.8 mm]

ANGLES ±1/2°