

CUSTOMER DRAWING

This drawing is the property of Rev-A-Shelf (RAS) and is disclosed in confidence to the extent its subject matter is original to RAS. Any vendor receiving this drawing from RAS shall hold and use this drawing for the sole benefit of RAS and shall not disclose it to, or use or reproduce it for any third party, or perform any act adverse to the interest of RAS with respect to this drawing without the express written permission of RAS. Vendors shall not revise any physical, dimensional or performance characteristic unless authorized by Rev-A-Shelf Engineering.

REV.	DATE	BY	DESCRIPTION OF CHANGE

INCH [MM]	AMERICAN PROJECTION 	BY	DATE	REV-A-SHELF, Inc.	
		DRAWN	KRR 1-4-23		
TOLERANCES		MATERIAL	DRAWING NO.	SCALE	
MAT. DEC. (WOOD) .XX ±.03 [.8mm] (OTHER) .XX ±.02 [.5mm] (ALL) .XXX ±.005 [.13 mm] FRACTIONS ±1/32 [.8 mm]		FINISH	4WDB-12SC-1	0.250	
ANGLES ±1/2°			PART NO.	SHEET OF	
			4WDB-12SC-1	1 2	

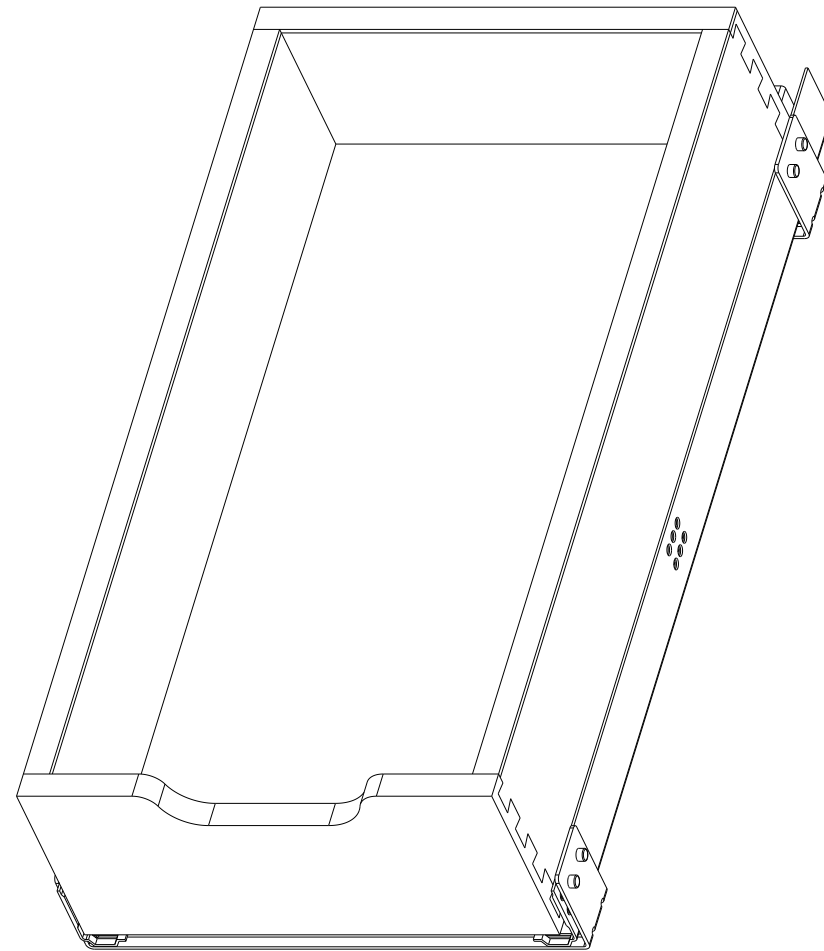

PART DIMENSIONS		
	MIN	MAX
WIDTH	11.71	
DEPTH	22.20	
HEIGHT	5.57	
CONTAINER CAPACITY		
CONTAINER UOM		

MIN CABINET OPENING				
	FACE FRAME	FRAMELESS	INSET FACE FRAME	INSET FRAMELESS
WIDTH	11.75	11.75	11.75	11.75
DEPTH	22.50	22.50	23.25	23.25
HEIGHT	5.75	5.75	5.75	5.75

SLIDE SPECIFICATIONS				
SLIDE MANUFACTURER	BLUM			
SLIDE PART NUMBER	554H5330B	RELEASE PART NUMBER	T51-1400	
SLIDE TYPE	UNDERMOUNT	SLIDE EXTENSION	7/8	MAX WEIGHT RATING
SLIDE CLOSING	SOFT	SLIDE LENGTH	22.05 [560]	
SLIDE MOUNTING	BOTTOM	SLIDE FINISH	ZINC	75 LB

CUSTOMER DRAWING

This drawing is the property of Rev-A-Shelf (RAS) and is disclosed in confidence to the extent its subject matter is original to RAS. Any vendor receiving this drawing from RAS shall hold and use this drawing for the sole benefit of RAS and shall not disclose it to, or use or reproduce it for any third party, or perform any act adverse to the interest of RAS with respect to this drawing without the express written permission of RAS. Vendors shall not revise any physical, dimensional or performance characteristic unless authorized by Rev-A-Shelf Engineering.

REV.	DATE	BY	DESCRIPTION OF CHANGE

INCH [MM]	AMERICAN PROJECTION	DRAWN	BY	DATE	REV-A-SHELF, INC.
			KRR	1-4-23	
			SIZE	WOOD PULL OUT DRAWER	
			MATERIAL	DRAWING NO.	SCALE
			FINISH	4WDB-12SC-1	0.250
				PART NO.	SHEET OF
				4WDB-12SC-1	2 OF 2

TOLERANCES
 MAT. DEC.
 (WOOD) .XX ±.03 [.8mm]
 (OTHER) .XX ±.02 [.5mm]
 (ALL) .XXX ±.005 [.13 mm]
 FRACTIONS ±1/32 [.8 mm]

ANGLES ±1/2°