

CUSTOMER DRAWING

This drawing is the property of Rev-A-Shelf (RAS) and is disclosed in confidence to the extent its subject matter is original to RAS. Any vendor receiving this drawing from RAS shall hold and use this drawing for the sole benefit of RAS and shall not disclose it to, or use or reproduce it for any third party, or perform any act adverse to the interest of RAS with respect to this drawing without the express written permission of RAS. Vendors shall not revise any physical, dimensional or performance characteristic unless authorized by Rev-A-Shelf Engineering.

REV.	DATE	BY	DESCRIPTION OF CHANGE

INCH [MM]	AMERICAN PROJECTION 	BY	DATE	REV-A-SHELF, INC.	
		DRAWN	LCS 6-07-22	SIZE	B
TOLERANCES		MATERIAL	DRAWING NO.	SCALE	0.188
MAT.	DEC.		4WCTM-1850DM2-419-FL	PART NO.	SHEET OF
(WOOD)	.XX ±.03 [8mm]	FINISH	4WCTM-1850DM2-419-FL		
(OTHER)	.XX ±.02 [5mm]				
(ALL)	.XXX ±.005 [13 mm]				
FRACTIONS ±1/32 [8 mm]					

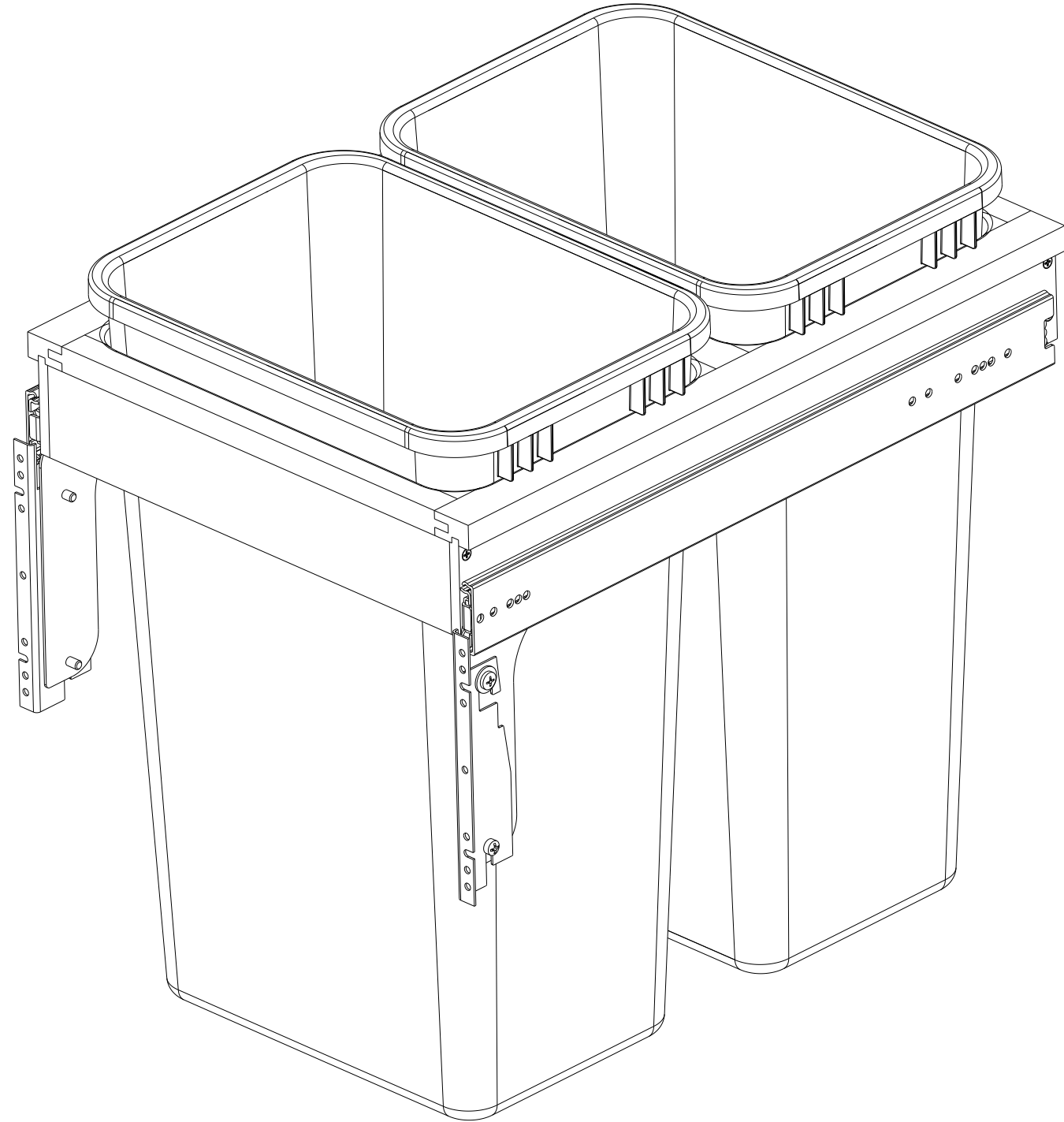

PART DIMENSIONS		
	MIN	MAX
WIDTH	16.50	
DEPTH	22.62	
HEIGHT	21.75	
CONTAINER CAPACITY	50	
CONTAINER UOM	QT	

MIN CABINET OPENING				
	FACE FRAME	FRAMELESS	INSET FACE FRAME	INSET FRAMELESS
WIDTH	16.50	16.50	16.50	16.50
DEPTH	23.00	23.00	23.75	23.75
HEIGHT	22.25	22.25	22.25	22.25

SLIDE SPECIFICATIONS				
SLIDE MANUFACTURER				
SLIDE PART NUMBER	FX8022	RELEASE PART NUMBER		
SLIDE TYPE	BALL BEARING	SLIDE EXTENSION	1-1/2" O.T.	MAX WEIGHT RATING
SLIDE CLOSING	NORMAL	SLIDE LENGTH	22.00" [560,0]	
SLIDE MOUNTING	SIDE	SLIDE FINISH	ZINC	150LB

CUSTOMER DRAWING

This drawing is the property of Rev-A-Shelf (RAS) and is disclosed in confidence to the extent its subject matter is original to RAS. Any vendor receiving this drawing from RAS shall hold and use this drawing for the sole benefit of RAS and shall not disclose it to, or use or reproduce it for any third party, or perform any act adverse to the interest of RAS with respect to this drawing without the express written permission of RAS. Vendors shall not revise any physical, dimensional or performance characteristic unless authorized by Rev-A-Shelf Engineering.

REV.	DATE	BY	DESCRIPTION OF CHANGE

INCH [MM]	AMERICAN PROJECTION	DRAWN	BY	DATE	REV-A-SHELF, INC.
			LCS	6-07-22	
			SIZE	FL DOUBLE 50QT TOP MOUNT	
			MATERIAL	DRAWING NO.	SCALE
			FINISH	4WCTM-1850DM2-419-FL	0.250
				4WCTM-1850DM2-419-FL	PART NO.
			TOLERANCES		
			MAT. DEC. (WOOD) .XX ±.03 [.8mm] (OTHER) .XX ±.02 [.5mm] (ALL) .XXX ±.005 [.13 mm] FRACTIONS ±1/32 [.8 mm]		
			ANGLES ±1/2°		