

# LED Tube Retrofit Solution

## Commercial Refrigeration Case

### Vertical Lighting

#### 60-INCH:

GELED14T8/5/835/RVA

GELED14T8/5/840/RVA

GELED14T8/5/850/RVA

#### 72-INCH:

GELED15T8/6/835/RVA

GELED15T8/6/840/RVA

GELED15T8/6/850/RVA



## BEFORE YOU BEGIN

Read these instructions completely and carefully.

### ⚠ CAUTION / ATTENTION

#### RISK OF INJURY

- Tube may fall down if not installed properly, follow installation instructions.
- While performing installations described, gloves, safety glasses or goggles should be worn.

#### RISK OF PRODUCT DAMAGE

- DO NOT INSTALL THIS LAMP IN A PRE-HEAT LUMINAIRE.
- Adequately IP rated lamp holders are required for applications requiring ingress protection ratings up to the IP65 rating of the lamp.
- This lamp may not be suitable for use in all applications where a traditional fluorescent lamp has been used. The temperature range of this lamp is more restricted. In cases of doubt regarding the suitability of the application the manufacturer of this lamp should be consulted.

### ⚠ WARNING / AVERTISSEMENT

#### RISK OF FIRE OR ELECTRICAL SHOCK

- LED Retrofit Kit installation requires knowledge of luminaires electrical systems. If not qualified, do not attempt installation. Contact a qualified electrician.
- Before installing, servicing or cleaning unit, switch power off at the service panel and follow appropriate lock out/tag out safety procedures.
- Install this kit only in luminaires used in refrigeration that have the construction features and dimensions shown in the photographs and/or drawings and where the input rating of the retrofit kit does not exceed the input rating of the luminaire.
- Do not alter, relocate, or remove wiring, lampholders, power supply, or any other electrical component.
- Do not make or alter any open holes in an enclosure of wiring or electrical components during kit installation.

## FOR YOUR SAFETY

Read and observe all **CAUTIONS** and **WARNINGS** shown throughout these instructions.

- GELED14T8/5/8xx/RVA is intended to replace a type 58W/60T8 fluorescent lamp and GELED15T8/6/8xx/RVA is intended to replace a type 70W/70T8 fluorescent lamp operating on an electronic ballast inside a commercial refrigeration case.
- This device is not intended for use with Emergency Exits.
- Use this unit only in the manner intended by the manufacturer. If you have any questions, contact the manufacturer.
- For packaged foods only.

### OPERATING TEMPERATURE

- Minimum is -20°C
- Maximum is 25°C
- Maximum TC point is 55°C

## Components

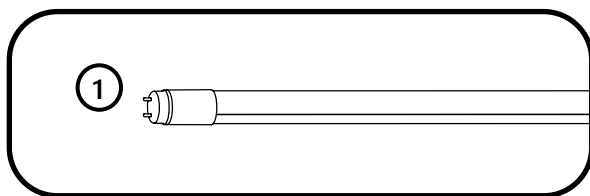

① LED Tube

## Components Installation

### ① Remove Existing Fluorescent Lamps

- Refer to manufacturing manual for refrigeration case to identify lighting control circuits. Ensure that power is switched off at the service panel for the lighting circuit. If a lighting power switch is not provided in the refrigeration case, power removal can be performed at the main breaker panel.
- Remove existing fluorescent lamps and dispose of them properly based on local regulations.
- Examine the existing lamp holders for signs of excessive wear, corrosion, or otherwise damaged. Replace any damaged parts with suitable new parts prior to installation of the retrofit LED tubes.

**⚠ WARNING**

To prevent wiring damage or abrasion, do not expose wiring to edges of sheet metal or other sharp objects.

### Fluorescent Component Location

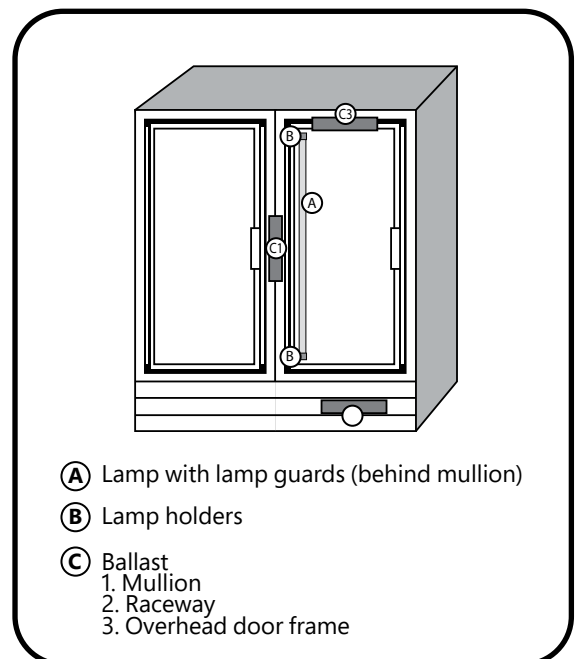

- Ⓐ Lamp with lamp guards (behind mullion)
- Ⓑ Lamp holders
- Ⓒ Ballast
  1. Mullion
  2. Raceway
  3. Overhead door frame

## 2 Select Installation Position

- Select installation position: Vertical.

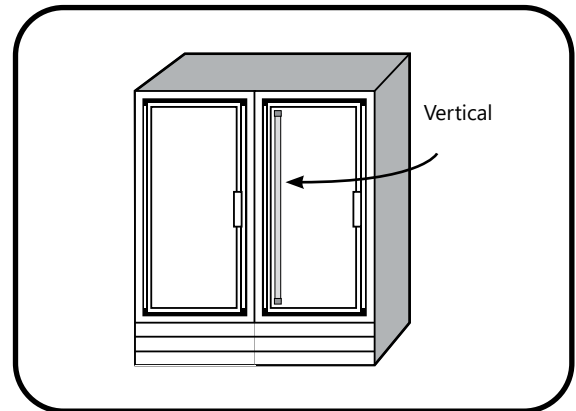

## 3 Install LED Tubes

- Rotate LED tube to the desired position, then insert the Immersion LED tube in the lampholders to a secured position. Make sure LEDs are facing to desired direction. Repeat for remaining tubes.
- Restore power and ensure lamps are operating correctly.

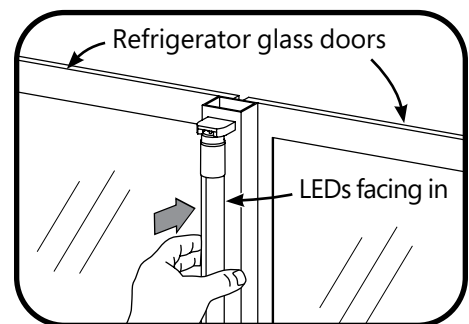

### ⚠ WARNING / AVERTISSEMENT

IF LAMP DOES NOT LIGHT WHEN THE LUMINAIRE IS ENERGIZED, REMOVE LAMP FROM THE LUMINAIRE AND CONTACT LAMP MANUFACTURER OR QUALIFIED ELECTRICIAN.

## 4 Cleaning Instructions

- The LED Light may be dusted as needed with a dry, clean, soft cloth.
- Do not use chemical cleaners on the system.
- Do not wipe with a soiled dishcloth or wet towel—these may leave a residue that can damage the finish.
- Do not use scouring pads, powdered cleaning products, bleach or cleaners containing bleach because these products can scratch and damage the finish.

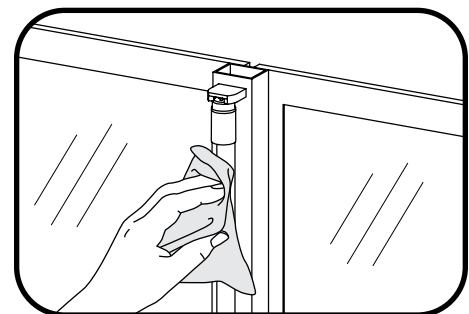

### ⚠ WARNING / AVERTISSEMENT

**Risk of electrical shock.** Disconnect power to LED Lights before any cleaning operation.

**Risque de choc électrique.** Débranchez l'alimentation des éclairages à LED avant toute opération de nettoyage.

## Product Specifications

Product	Output Watts
GELED14T8/5/835/RVA	13.2
GELED14T8/5/840/RVA	13.2
GELED14T8/5/850/RVA	13.2
GELED15T8/6/835/RVA	15.9
GELED15T8/6/840/RVA	15.9
GELED15T8/6/850/RVA	15.9

## LED Ballast Compatibility

- GELED14T8/5/8xx/RVA is intended to replace a type 58W/60T8 fluorescent lamp and GELED15T8/6/8xx/RVA is intended to replace a type 70W/70T8 fluorescent lamp operating on an electronic ballast inside a commercial refrigeration case.
- For a list of ballasts with known compatibility: <https://LED.com>

**NOTE:** Contact Current sales representatives if the ballast to be used to operate the lamp is not shown in the list.

This device complies with Part 18 of the FCC Rules. This product may cause interference to radio equipment and should not be installed near marine safety communications equipment or other critical navigation or communication equipment operating between 0.45-30 MHz.

This product is intended solely for the use of commercial refrigerated, display or case lighting and is not intended for use in any other application.

Conforms to the following:



Current Lighting Solutions LLC  
25825 Science Park Dr, Cleveland, OH 44122, United States