

4

3

2

1

B

B

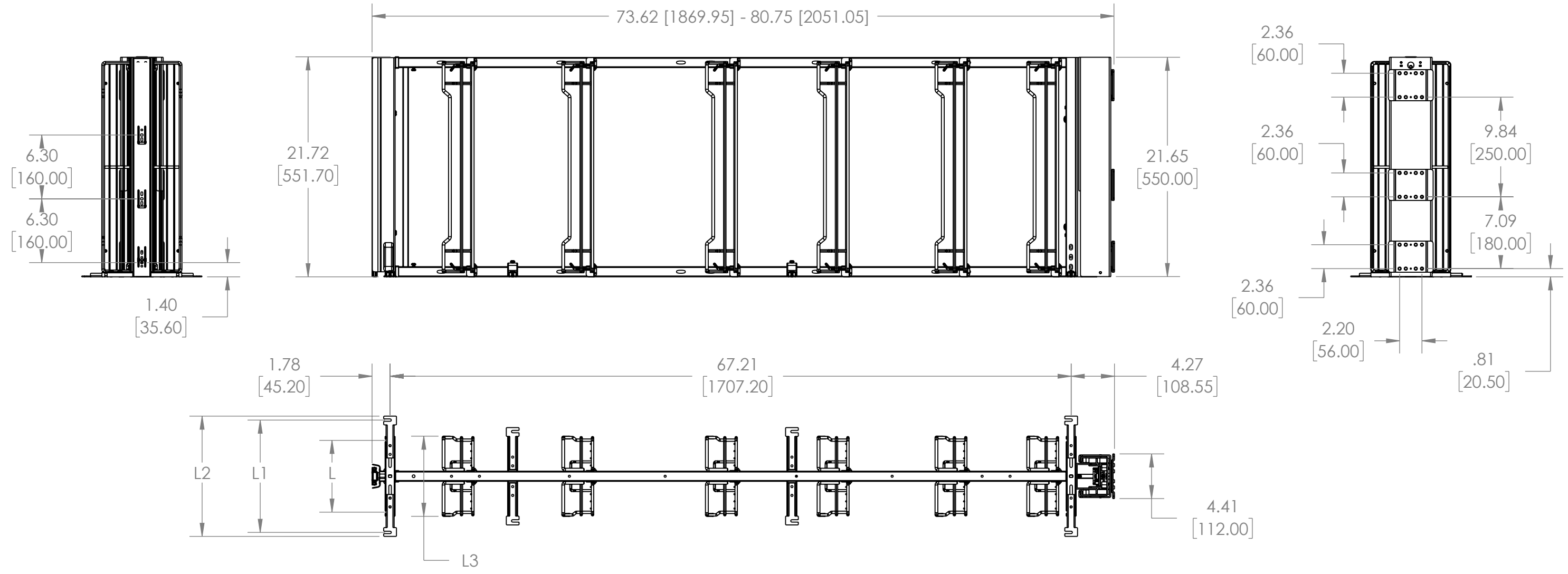

PART NO.	L	L1 MIN	L1 MAX	L2 MIN	L2 MAX	L3
5773-04-CR-1	3.15 [80]	6.06 [154]	7.25 [184]	6.85 [174]	8.04 [204]	4.02 [102]
5773-08-CR-1	7.09 [180]	8.75 [222]	11.09 [282]	9.54 [242]	11.87 [302]	7.91 [201]
5773-10-CR-1	9.06 [230]	10.75 [273]	13.03 [331]	11.54 [293]	13.82 [351]	9.92 [252]
5773-14-CR-1	13.07 [332]	14.75 [375]	17.07 [434]	15.54 [395]	17.86 [454]	13.94 [354]
5773-16-CR-1	15.08 [383]	16.75 [425]	19.08 [485]	17.54 [446]	19.87 [505]	15.91 [404]
5773-20-CR-1	19.09 [485]	20.75 [527]	23.09 [587]	21.54 [547]	23.88 [607]	19.92 [506]

CUSTOMER DRAWING

5773 SERIES WIRE PANTRY PULLOUT

PART NO. 5773-XX-CR-1

SIZE **B** DWG. NO. 5773-XX-CR-1_CUST REV

SCALE: 1:10 WEIGHT: SHEET 1 OF 2

UNLESS OTHERWISE SPECIFIED:		
TOLERANCES = INCH/(MM)		
MAT. DEC.		
(WOOD) .XX +/- .03 [.8mm]		
(OTHER) .XX +/- .02 [.5mm]		
(ALL) .XXX +/- .005 [.13 mm]		
FRACTIONS +/- 1/32 [.8 mm]		
ANGLES +/- 1/2°		
First Angle Projection		
MATERIAL	FINISH	
DO NOT SCALE DRAWING	NAME	DATE
DRAWN	LCS	6-7-23



PROPRIETARY AND CONFIDENTIAL
 This drawing is the property of Rev-A-Shelf LLC (RAS) and is disclosed in confidence to the extent its subject matter is original to RAS. Any vendor receiving this drawing from RAS shall hold and use this drawing for the sole benefit of RAS and shall not disclose it to, or use or reproduce it for any third party, or perform any act adverse to the interest of RAS with respect to this drawing without the express written permission of RAS. Vendors shall not revise any physical, dimensional or performance characteristic unless authorized by Rev-A-Shelf Engineering.

REV	DATE	BY	DESCRIPTION OF CHANGE
A	11-10-23	KRR	UPDATED MCO

4

3

2

1

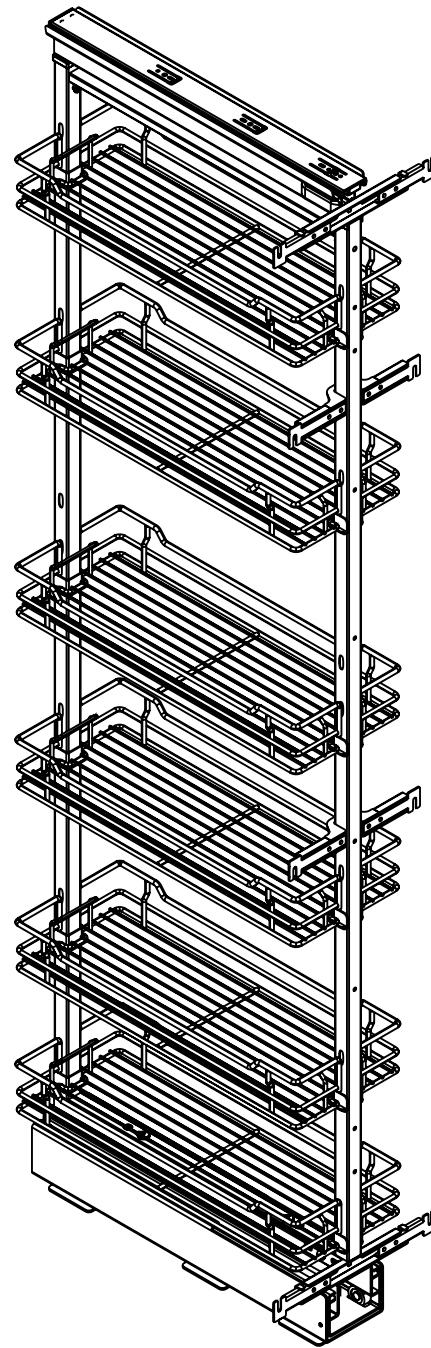

PART NO.	A	B	C
5773-04-CR-1	4.41 [112]	8.04 [204]	4.50 [114]
5773-08-CR-1	8.00 [203]	11.87 [302]	8.50 [216]
5773-10-CR-1	10.00 [254]	13.82 [351]	10.50 [267]
5773-14-CR-1	14.00 [356]	17.86 [454]	14.50 [368]
5773-16-CR-1	16.00 [406]	19.87 [505]	16.50 [419]
5773-20-CR-1	20.00 [508]	23.88 [607]	20.50 [521]

PART DIMENSIONS		
	MIN	MAX
WIDTH	A	B
DEPTH	21.72 [551.70]	
HEIGHT	73.62 [1869.95]	80.75 [2051.05]

MIN CABINET OPENING				
	FACE FRAME	FRAMELESS	INSET FACE FRAME	INSET FRAMELESS
WIDTH	C	C	C	C
DEPTH	21.75 [552.5]	21.75 [552.5]	22.50 [571.5]	22.50 [571.5]
HEIGHT	73.62 [1869.95]	73.62 [1869.95]	73.62 [1869.95]	73.62 [1869.95]

SLIDE SPECIFICATIONS				
SLIDE TYPE	HEAVY DUTY	SLIDE EXTENSION	20.87 [530]	MAX WEIGHT RATING
SLIDE CLOSING	SOFT CLOSE	SLIDE LENGTH	21.65 [550]	
SLIDE MOUNTING	FLOOR	SLIDE FINISH	ZINC	250 LB

CUSTOMER DRAWING



PROPRIETARY AND CONFIDENTIAL

This drawing is the property of Rev-A-Shelf LLC (RAS) and is disclosed in confidence to the extent its subject matter is original to RAS. Any vendor receiving this drawing from RAS shall hold and use this drawing for the sole benefit of RAS and shall not disclose it to, or use or reproduce it for any third party, or perform any act adverse to the interest of RAS with respect to this drawing without the express written permission of RAS. Vendors shall not revise any physical, dimensional or performance characteristic unless authorized by Rev-A-Shelf Engineering.

REV	DATE	BY	DESCRIPTION OF CHANGE
A	11-10-23	KRR	UPDATED MCO

UNLESS OTHERWISE SPECIFIED:

TOLERANCES = INCH/(MM)
 MAT. DEC.
 (WOOD) .XX +/- .03 [.8mm]
 (OTHER) .XX +/- .02 [.5mm]
 (ALL) .XXX +/- .005 [.13 mm]
 FRACTIONS +/- 1/32 [.8 mm]
 ANGLES +/- 1/2°

First Angle Projection



MATERIAL

FINISH

DO NOT SCALE DRAWING

NAME

DATE

DRAWN

LCS

6-7-23

Description:

**5773 SERIES
 WIRE PANTRY PULLOUT**

PART NO. 5773-XX-CR-1

SIZE

DWG. NO.

B

5773-XX-CR-1_CUST

REV

SCALE: 1:10 WEIGHT:

SHEET 2 OF 2

4

3

2

1

B

A