

# STRUCTURAL CEILING SYSTEM

Structural ceilings, designed to support heavy loads, are extensively used in data centres with Atkore Unistrut being preferred amongst MEP applications in data centres.

Our structural ceiling system allows you to continue with a proven method that is widely specified and accepted for successful completion of these project types. A key advantage of our system is that it not only supports ceiling tiles, but also allows you to install heavier elements to the structure.

## Ceiling Grid System

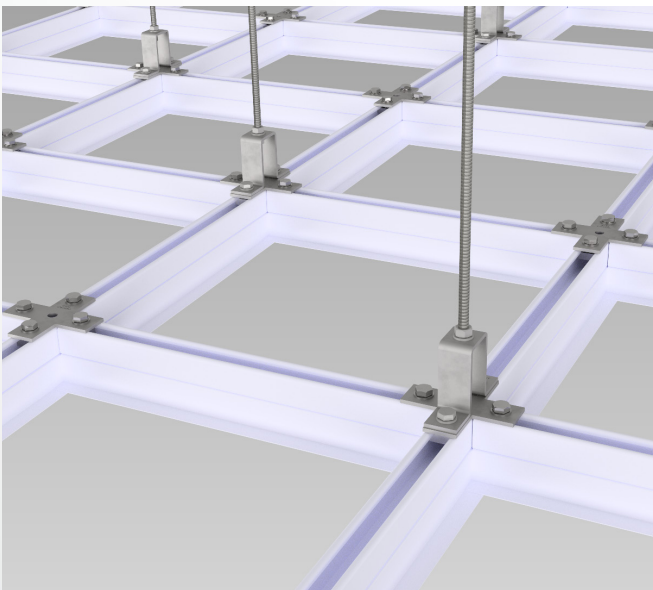

- ▲ Designed to support miscellaneous mechanical and electrical equipment, decorative panels, and lighting
- ▲ Versatile grid system allows attachments to be made anywhere along the channel opening
- ▲ An abundance of available fittings allows for significant time and labour cost savings
- ▲ With an infinitely adjustable nature of structures built with Atkore Unistrut, your new ceiling grid can easily adapt to changing needs

## Load Table

L (mm)	F <sub>max</sub> (kN)	$\sigma = 175 \text{ N/mm}^2$ F f	f <sub>max</sub> (mm)	F (kN) f = 1/200L	F (kN) f = 1/360L	F (kN) ↓ TTTTTTTT
250	-		-	-	-	28.253
500	-		-	-	-	28.096
750	16.383		1.21	-	-	27.792
1000	12.292		2.15	-	-	27.301
1250	9.830		3.36	-	-	26.438
1500	8.191		4.84	-	7.044	25.025
1750	7.024		6.59	-	5.170	23.220
2000	6.141		8.61	-	3.963	21.288
2250	5.454		10.89	-	3.129	19.394
2500	4.915		13.45	4.562	2.531	17.619
2750	4.464		16.27	3.767	2.090	15.990
3000	4.091		19.37	3.169	1.756	14.519

NB: Load data is for Mild Steel channels

### DEG - Data Edging Grid Channel

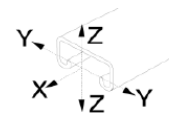
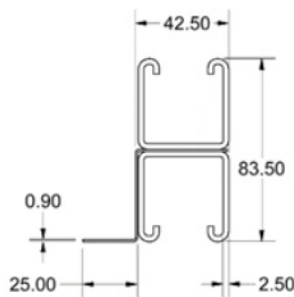
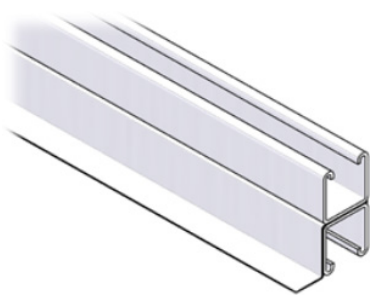

- A = 6.70 cm<sup>2</sup>
- W/m = 5.77 kg/m
- I<sub>y-y</sub> = 36.27 cm<sup>4</sup>
- Z<sub>y-y</sub> = 8.78 cm<sup>3</sup>
- r<sub>y-y</sub> = 2.32 cm
- I<sub>z-z</sub> = 18.46 cm<sup>4</sup>
- Z<sub>z-z</sub> = 8.94 cm<sup>3</sup>
- r<sub>z-z</sub> = 1.66 cm

### DSG - Data Service Grid Channel

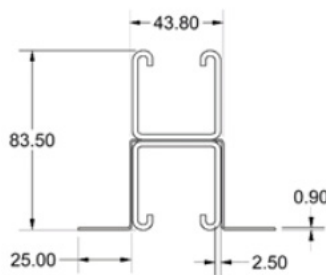
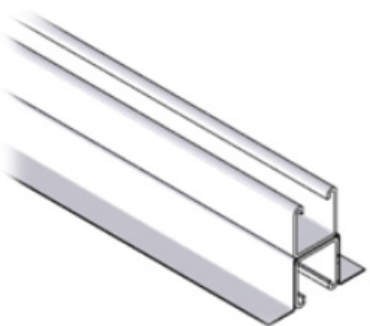

## Contact Us!

For further information, contact our sales team today.

Email [enquiries@atkore.com](mailto:enquiries@atkore.com)

Office 0121 580 6300

Web [unistrut.co.uk](http://unistrut.co.uk)

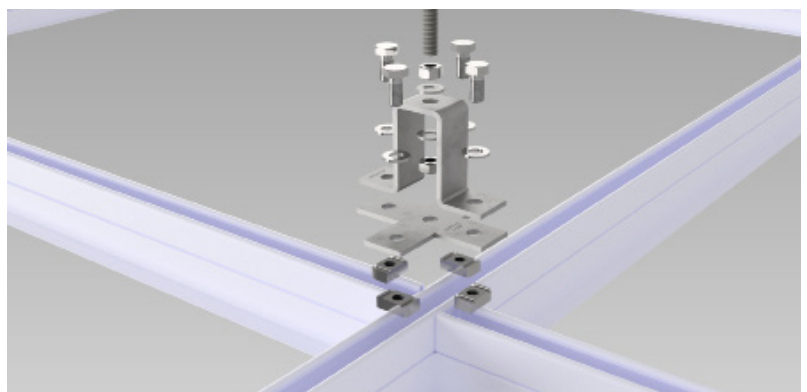

For more info visit [unistrut.co.uk](http://unistrut.co.uk)

©2024 Atkore All rights reserved. UK-SS-SCG-2403