

CUSTOMER DRAWING

This drawing is the property of Rev-A-Shelf (RAS) and is disclosed in confidence to the extent its subject matter is original to RAS. Any vendor receiving this drawing from RAS shall hold and use this drawing for the sole benefit of RAS and shall not disclose it to, or use or reproduce it for any third party, or perform any act adverse to the interest of RAS with respect to this drawing without the express written permission of RAS. Vendors shall not revise any physical, dimensional or performance characteristic unless authorized by Rev-A-Shelf Engineering.

REV.	DATE	BY	DESCRIPTION OF CHANGE

INCH [MM]	AMERICAN PROJECTION	BY	DATE	
		JAB	4/3/23	
TOLERANCES		MATERIAL	DRAWING NO.	SCALE
MAT.	DEC.	FINISH	5WU2-9N3-1	0.375
(WOOD) .XX ±.03 [8mm]	(OTHER) .XX ±.02 [5mm]		PART NO.	5WU2-9N3-1
(ALL) .XXX ±.005 [13 mm]	FRACTIONS ±1/32 [8 mm]			1 2

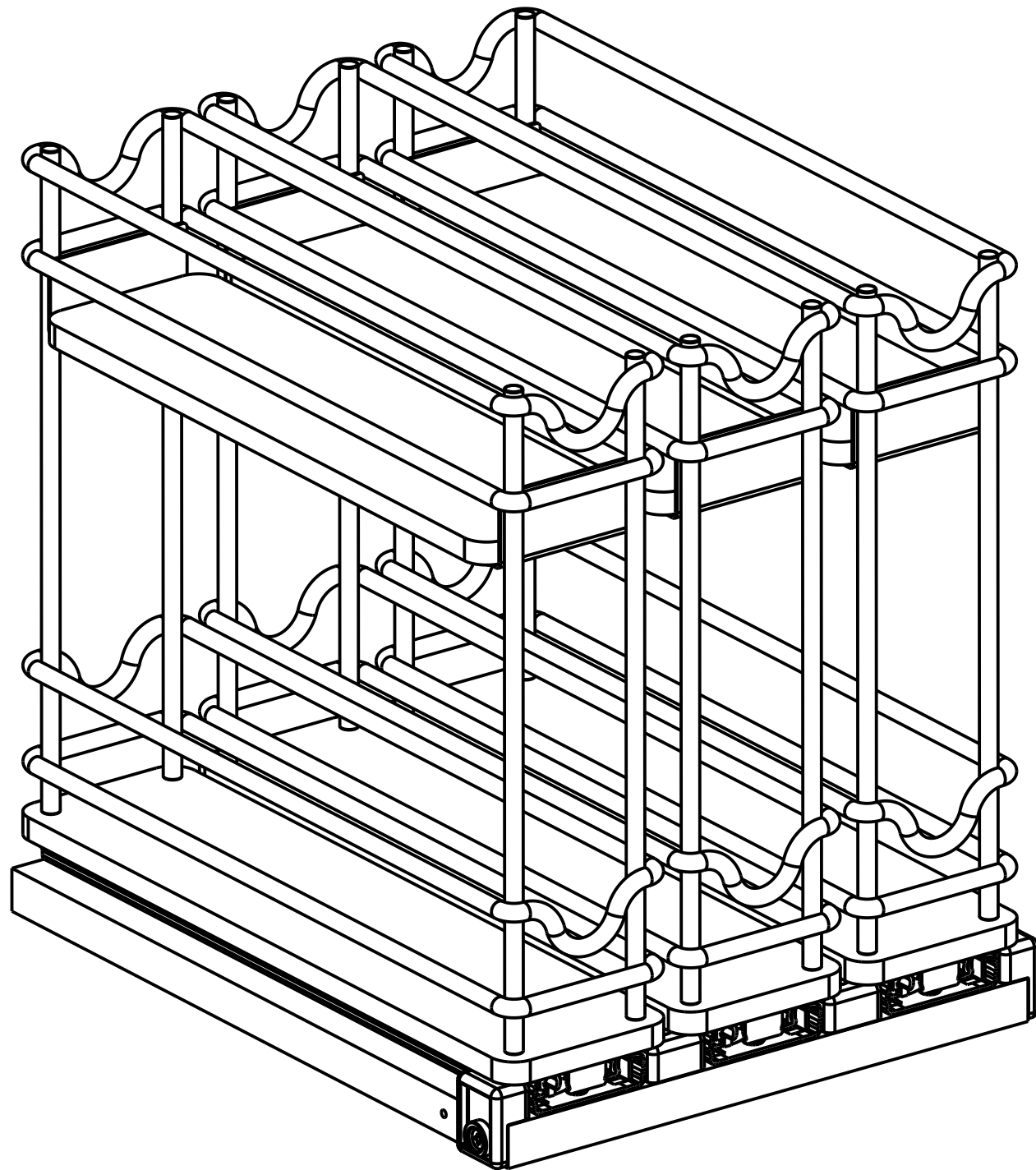

PART DIMENSIONS		
	MIN	MAX
WIDTH	8.59	
DEPTH	10.60	
HEIGHT	10.50	
WEIGHT		
DIAMETER		N/A
RADIUS		N/A
CONTAINER CAPACITY		N/A
CONTAINER UOM		N/A

MIN CABINET OPENING	
WIDTH	9.00
HEIGHT	12.00/14.00 DEPENDENT ON TOP-TIER JAR SIZE
DEPTH	10.75

PRODUCT WEIGHT RATING	
10 LBS/PULLOUT	

SLIDE SPECIFICATIONS			
SLIDE TYPE	BALL BEARING	SLIDE EXTENSION	7/8
SLIDE CLOSING	NORMAL	SLIDE LENGTH	10.50
SLIDE MOUNTING	BOTTOM	SLIDE FINISH	ZINC

This drawing is the property of Rev-A-Shelf (RAS) and is disclosed in confidence to the extent its subject matter is original to RAS. Any vendor receiving this drawing from RAS shall hold and use this drawing for the sole benefit of RAS and shall not disclose it to, or use or reproduce it for any third party, or perform any act adverse to the interest of RAS with respect to this drawing without the express written permission of RAS. Vendors shall not revise any physical, dimensional or performance characteristic unless authorized by Rev-A-Shelf Engineering.

REV.	DATE	BY	DESCRIPTION OF CHANGE

INCH [MM]	AMERICAN PROJECTION	BY	DATE		
		JAB	4/3/23		
TOLERANCES		MATERIAL	DRAWING NO.		
MAT. DEC. (WOOD) .XX ±.03 [.8mm] (OTHER) .XX ±.02 [.5mm] (ALL) .XXX ±.005 [.13 mm] FRACTIONS ±1/32 [.8 mm]		FINISH	5WU2-9N3-1		SCALE
ANGLES ±1/2°		PART NO.		SHEET OF	
		5WU2-9N3-1		2 2	

CUSTOMER DRAWING

REV-A-SHELF, INC.

SIZE B 9" TWO-TIER WALL TRIPLE NARROW UPRIGHT STORAGE PULLOUT

DRAWING NO. 5WU2-9N3-1 SCALE 0.500

PART NO. 5WU2-9N3-1 SHEET OF 2 2