

- NOTES:
 1. FINISH: MAPLE
 2. HOLDS (2) 50 QT WASTE CONTAINERS
 3. HOLDS (2) 8 L WASTE CONTAINERS

CUSTOMER DRAWING

This drawing is the property of Rev-A-Shelf (RAS) and is disclosed in confidence to the extent its subject matter is original to RAS. Any vendor receiving this drawing from RAS shall hold and use this drawing for the sole benefit of RAS and shall not disclose it to, or use or reproduce it for any third party, or perform any act adverse to the interest of RAS with respect to this drawing without the express written permission of RAS. Vendors shall not revise any physical, dimensional or performance characteristic unless authorized by Rev-A-Shelf Engineering.

REV.	DATE	BY	DESCRIPTION OF CHANGE

INCH [MM]	AMERICAN PROJECTION	BY	DATE	REV-A-SHELF, INC.
		JAB	10/10/23	
DRAWN				SIZE
TOLERANCES				DRAWING NO.
MAT.	DEC.	ANGLES ±1/2°	MATERIAL	4WCWM-2450DMSC-4
(WOOD) .XX ±.03 [.8mm]	(OTHER) .XX ±.02 [.5mm]		FINISH	SCALE
(ALL) .XXX ±.005 [.13 mm]	FRACTIONS ±1/32 [.8 mm]		PART NO.	4WCWM-2450DMSC-4
			SHEET OF	1 2

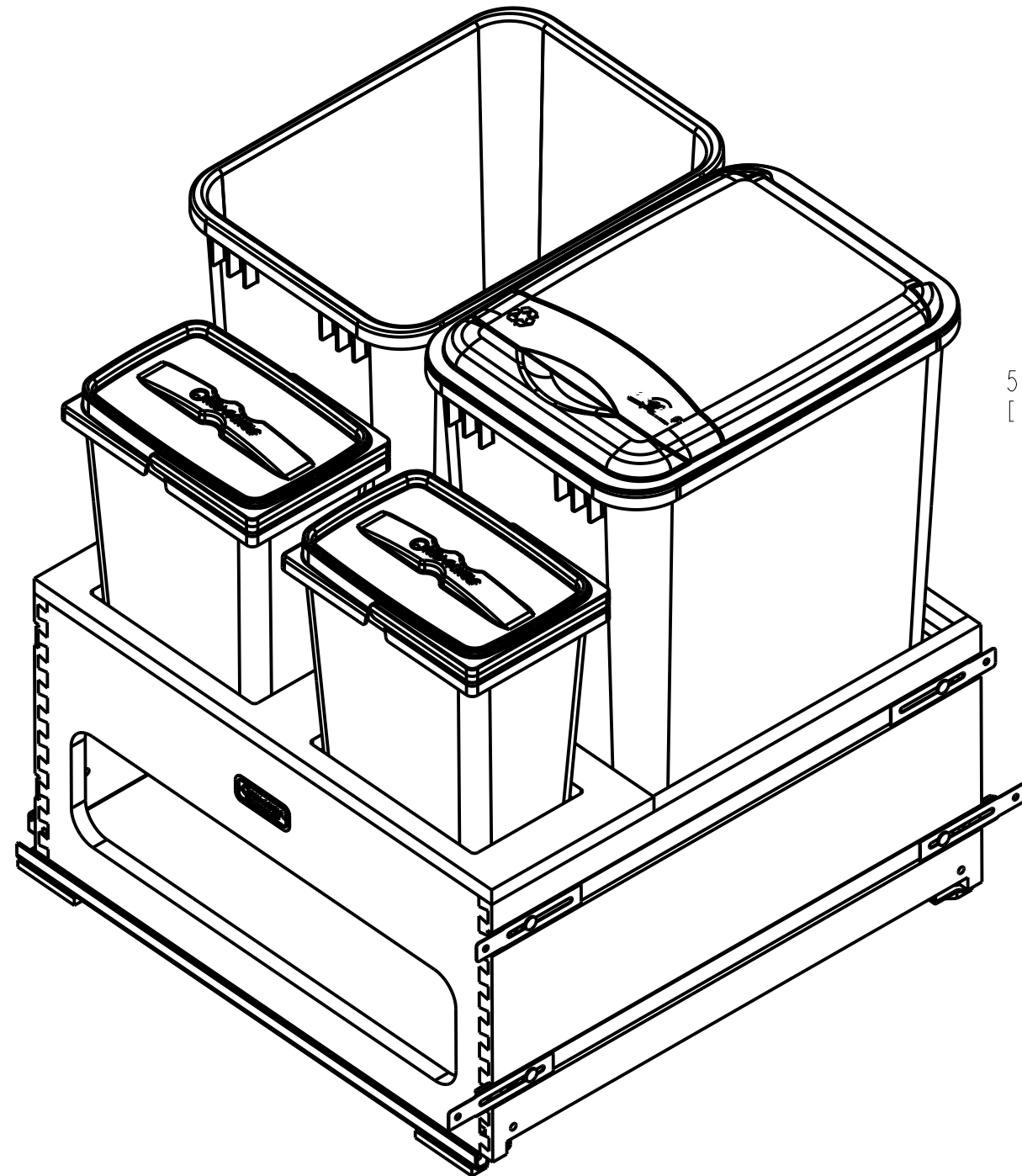

5.63
[143]

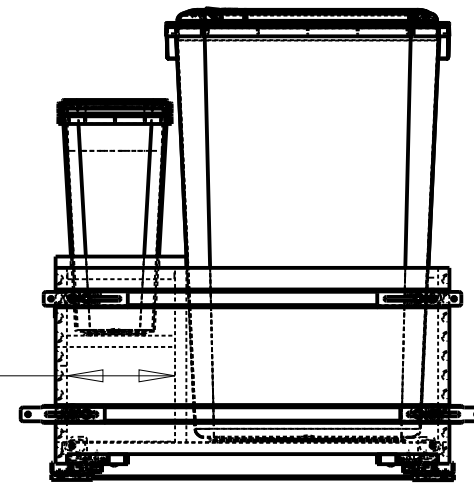

SCALE 0.100

PART DIMENSIONS

	MIN	MAX
WIDTH	20.97	
DEPTH	22.04	
HEIGHT	24.57	
CONTAINER CAPACITY	50/8	
CONTAINER UOM	QUART/LITER	

MIN CABINET OPENING

	FACE FRAME	FRAMELESS	INSET FACE FRAME	INSET FRAMELESS
WIDTH	21	21	21	21
DEPTH	22.13	22.13	22.88	22.88
HEIGHT	25	25	25	25

SLIDE SPECIFICATIONS

SLIDE MANUFACTURER	BLUM	RELEASE PART NUMBER	T51.7601	MAX WEIGHT RATING
SLIDE PART NUMBER	769R5330M	SLIDE EXTENSION	OVER-TRAVEL	
SLIDE TYPE	UNDERMOUNT	SLIDE LENGTH	21	155 LBS
SLIDE CLOSING	SOFT CLOSE	SLIDE FINISH	ZINC	
SLIDE MOUNTING	BOTTOM			

CUSTOMER DRAWING

This drawing is the property of Rev-A-Shelf (RAS) and is disclosed in confidence to the extent its subject matter is original to RAS. Any vendor receiving this drawing from RAS shall hold and use this drawing for the sole benefit of RAS and shall not disclose it to, or use or reproduce it for any third party, or perform any act adverse to the interest of RAS with respect to this drawing without the express written permission of RAS. Vendors shall not revise any physical, dimensional or performance characteristic unless authorized by Rev-A-Shelf Engineering.

REV.	DATE	BY	DESCRIPTION OF CHANGE

INCH [MM]	AMERICAN PROJECTION	DRAWN	BY	DATE	
		JAB		10/10/23	
TOLERANCES		MATERIAL		DRAWING NO.	SCALE
MAT.	DEC.	FINISH		4WCWM-2450DMSC-4	0.200
(WOOD) .XX ±.03 [.8mm]				PART NO.	SHEET OF
(OTHER) .XX ±.02 [.5mm]	ANGLES ±1/2°			4WCWM-2450DMSC-4	2 OF 2
(ALL) .XXX ±.005 [.13 mm]					
FRACTIONS ±1/32 [.8 mm]					