

4

3

2

1

B

B

A

A

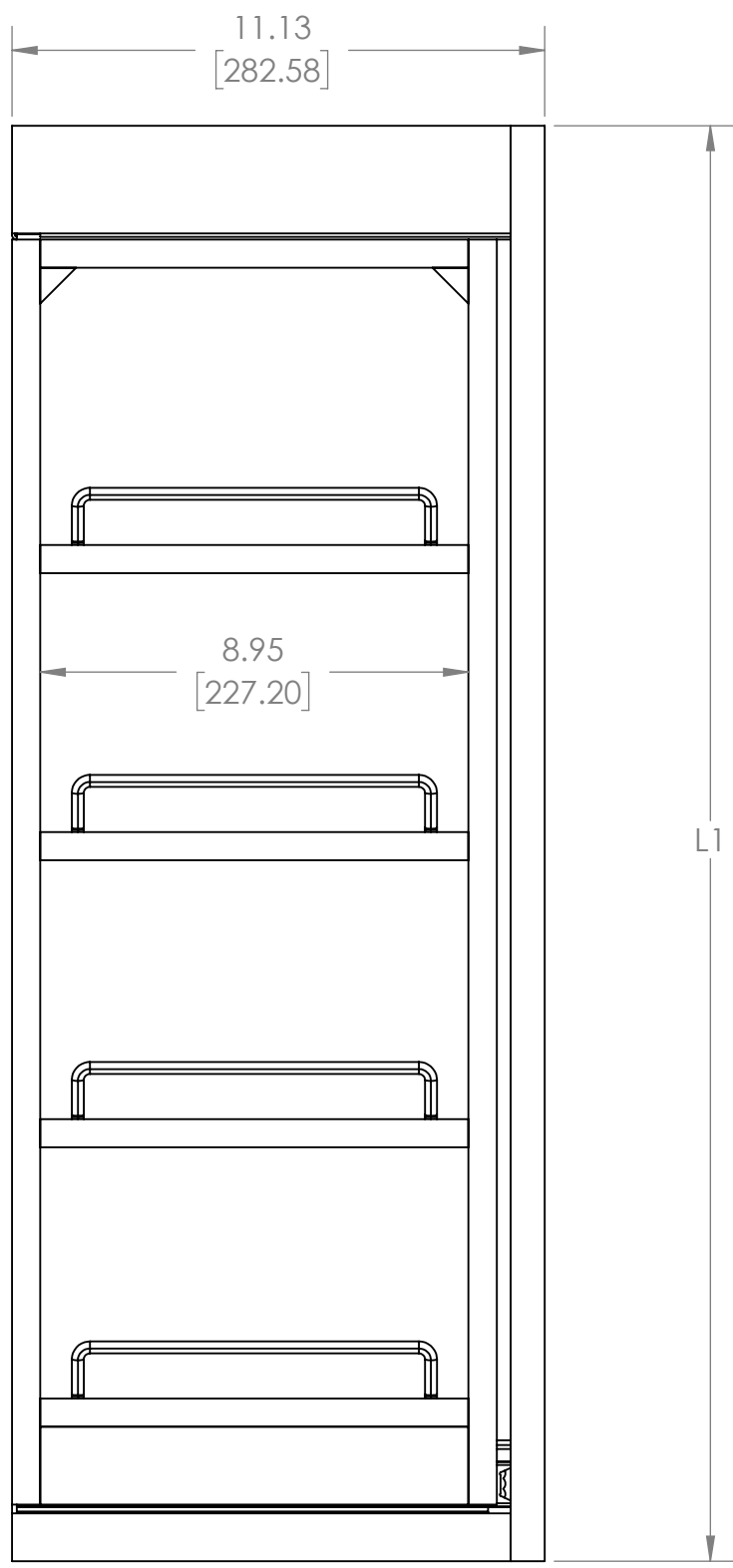
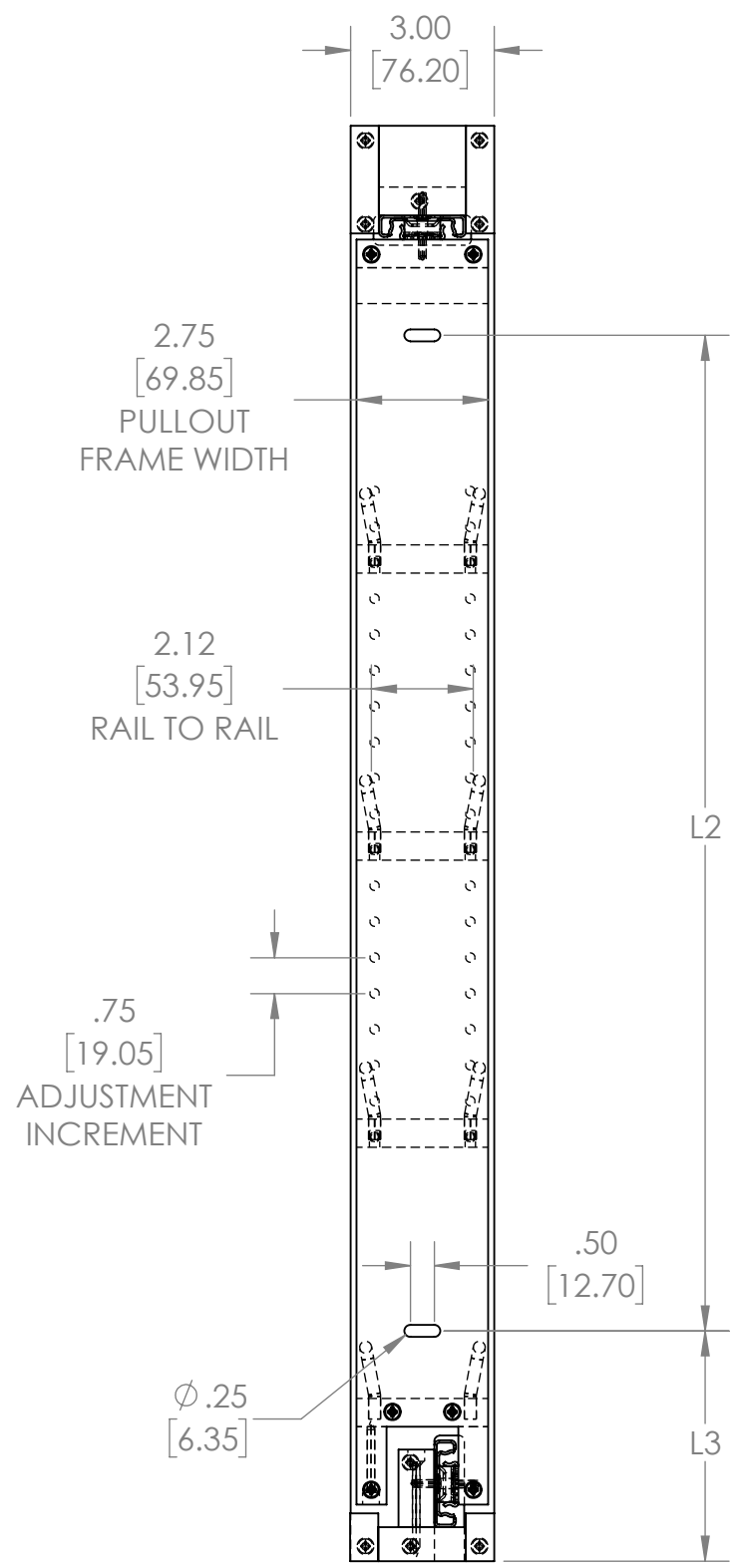

PART NO.	L1	L2	L3
432-WF-3C	30.00 [762]	20.81 [528.6]	4.82 [122.3]
432-WF33-3C	33.00 [838.2]	23.31 [592]	5.31 [134.9]
432-WF36-3C	36.00 [914.4]	26.81 [680.9]	5.31 [134.9]
432-WF39-3C	39.00 [990.6]	29.31 [744.5]	5.31 [134.9]
432-WF42-3C	42.00 [1066.8]	32.31 [820.7]	5.31 [134.9]

REV-A-SHELF

PROPRIETARY AND CONFIDENTIAL

This drawing is the property of Rev-A-Shelf LLC (RAS) and is disclosed in confidence to the extent its subject matter is original to RAS. Any vendor receiving this drawing from RAS shall hold and use this drawing for the sole benefit of RAS and shall not disclose it to, or use or reproduce it for any third party, or perform any act adverse to the interest of RAS with respect to this drawing without the express written permission of RAS. Vendors shall not revise any physical, dimensional or performance characteristic unless authorized by Rev-A-Shelf Engineering.

REV	DATE	BY	DESCRIPTION OF CHANGE

UNLESS OTHERWISE SPECIFIED:

TOLERANCES = INCH/(MM)
 MAT. DEC.
 (WOOD) .XX +/--.03 [.8mm]
 (OTHER) .XX +/--.02 [.5mm]
 (ALL) .XXX +/--.005 [.13 mm]
 FRACTIONS +/-1/32 [.8 mm]
 ANGLES +/-1/2°

First Angle Projection

MATERIAL FINISH

DO NOT SCALE DRAWING NAME DATE

DRAWN LCS 6-9-23

Description:
3" 432 WALL FILLER

PART NO. 432-WFXX-3C

SIZE **B** DWG. NO. 432-WFXX-3C_CUST REV

SCALE: 1:4 WEIGHT: SHEET 1 OF 2

4

3

2

1

4

3

2

1

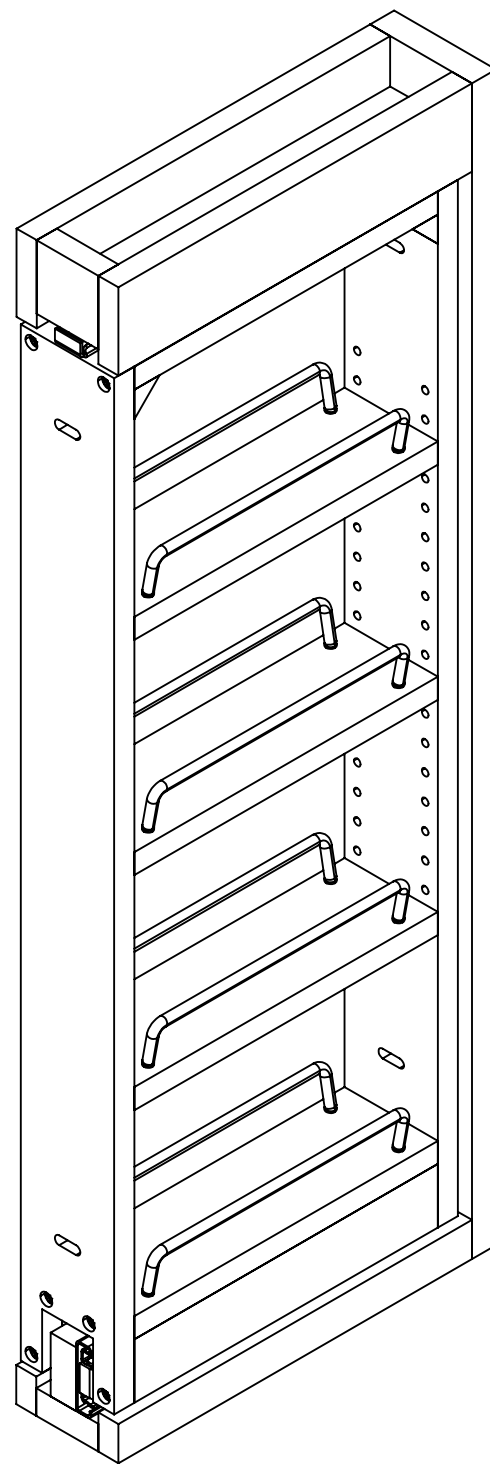

PART NO.	A	NO. SHELVES
432-WF-3C	30.00 [762]	4 (3 ADJUSTABLE)
432-WF33-3C	33.00 [838.2]	5 (4 ADJUSTABLE)
432-WF36-3C	36.00 [914.4]	5 (4 ADJUSTABLE)
432-WF39-3C	39.00 [990.6]	6 (5 ADJUSTABLE)
432-WF42-3C	42.00 [1066.8]	6 (5 ADJUSTABLE)

PART DIMENSIONS	
WIDTH	3.00 [76.2]
DEPTH	11.13 [282.6]
HEIGHT	A

MCO: N/A (PRODUCT INSTALLS BETWEEN TWO CABINETS)

PRODUCT MAX WEIGHT RATING
BMHA STANDARDS

SLIDE SPECIFICATIONS				
SLIDE TYPE	BALL BEARING	SLIDE EXTENSION	FULL	MAX WEIGHT RATING
SLIDE CLOSING	N/A	SLIDE LENGTH	267 MM	
SLIDE MOUNTING	N/A	SLIDE FINISH	ZINC	100 LB

UNLESS OTHERWISE SPECIFIED:		Description:	
TOLERANCES = INCH/(MM) MAT. DEC. (WOOD) .XX +/--.03 [.8mm] (OTHER) .XX +/--.02 [.5mm] (ALL) .XXX +/--.005 [.13 mm] FRACTIONS +/-1/32 [.8 mm] ANGLES +/-1/2°		3" 432 WALL FILLER	
First Angle Projection		PART NO. 432-WFXX-3C	
MATERIAL	FINISH	SIZE	DWG. NO.
		B	432-WFXX-3C_CUST
DO NOT SCALE DRAWING	NAME	DATE	REV
DRAWN	LCS	6-9-23	
SCALE: 1:4		WEIGHT:	SHEET 2 OF 2



PROPRIETARY AND CONFIDENTIAL
This drawing is the property of Rev-A-Shelf LLC (RAS) and is disclosed in confidence to the extent its subject matter is original to RAS. Any vendor receiving this drawing from RAS shall hold and use this drawing for the sole benefit of RAS and shall not disclose it to, or use or reproduce it for any third party, or perform any act adverse to the interest of RAS with respect to this drawing without the express written permission of RAS. Vendors shall not revise any physical, dimensional or performance characteristic unless authorized by Rev-A-Shelf Engineering.

REV	DATE	BY	DESCRIPTION OF CHANGE

4

3

2

1

B

B

A

A