

STC0325

High Torque Servo Tool Changer

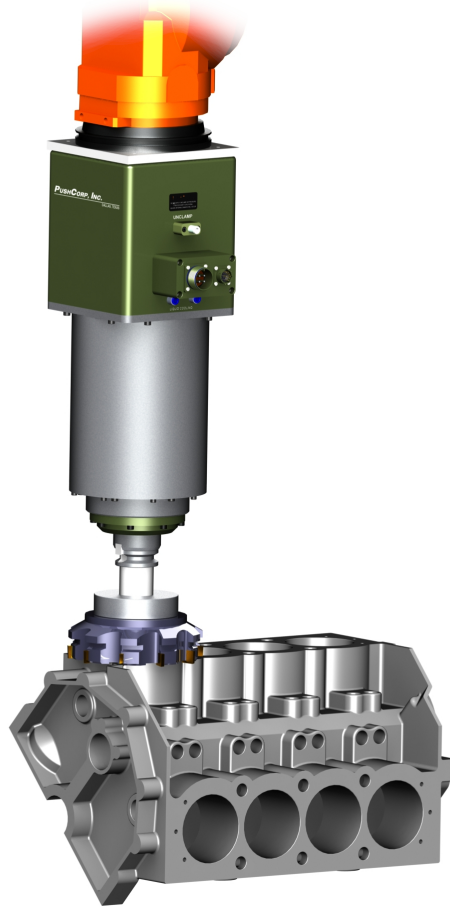

PUSHCORP, INC.

Dallas, Texas

May, 2017

! CAUTION !

Do **NOT** apply air pressure to release the Collet while the servo motor is rotating. The servo motor spindle must be ***FULLY STOPPED*** before actuating the Collet.

Do **NOT** overheat the servo motor. Supply the motor cooling water to maintain a temperature below 176 °F (80 °C).

Do **NOT** start or stop the servo motor instantaneously. Doing so will damage the motor and power amplifier.

All *PushCorp, Inc.* electrical cables are rated for high twist and flex robotic applications with a minimum cable bending radius specification of 125mm (5 in). Cable damage resulting from failure to abide by this specification will not be covered under warranty.

1.0 LIMITED WARRANTY	1
2.0 GENERAL OVERVIEW	3
3.0 INSTALLATION	4
3.1 Mounting the STC0325.....	4
3.1.1 Mounting to an AFD1200/90.....	4
3.1.2 Mounting Directly to a Robot.....	5
3.2 Toolholder Specification.....	6
3.3 Pneumatic Connection.....	7
3.4 Electrical Connections.....	9
3.5 Motor Cooling.....	10
3.7 Monitoring Motor Temperature.....	12
3.8 Motor Acceleration/Deceleration.....	12
3.8 Positioning Motor Shaft for Tool Change.....	12
4.0 TECHNICAL SPECIFICATIONS	13
5.0 PREVENTATIVE MAINTENANCE SCHEDULE	14

1.0 Limited Warranty

Duration:

One year from date of delivery to the original purchaser.

Who gives this warranty (warrantor):

PushCorp, Inc.

Telephone: (972) 840-0208

Corporate Address:

P. O. Box 181915

Dallas, Texas 75218

Shipping Address:

3001 W Kingsley Rd

Garland, Texas 75041

Who receives this warranty (purchaser):

The original purchaser (other than for purposes of resale) of the *PushCorp, Inc.* product

What products are covered by this warranty:

Any *PushCorp, Inc.* industrial equipment or accessory supplied or manufactured by the Warrantor.

What is covered under this warranty:

Defects in material and/or workmanship which occur within the duration of the warranty period.

What is NOT covered in this warranty:

- A. IMPLIED WARRANTIES, INCLUDING THOSE OF MERCHANTABILITY AND FITNESS FOR A PARTICULAR PURPOSE ARE LIMITED TO ONE YEAR FROM THE DATE OF ORIGINAL PURCHASE. Some states do not allow limitations on how long an implied warranty lasts, so the above limitations may not apply to you.
- B. ANY INCIDENTAL, INDIRECT, OR CONSEQUENTIAL LOSS, DAMAGE or EXPENSE THAT MAY RESULT FROM ANY DEFECT, FAILURE, MALFUNCTION OF THE *PUSHCORP, INC.* PRODUCT. Some states do not allow the exclusion or limitation of incidental or consequential damages so the above limitation or exclusion may not apply to you.
- C. Any failure that results from an accident, purchaser's abuse, neglect, unauthorized repair or failure to operate the products in accordance with the instructions provided in the owner's manual(s) supplied with the product.

Responsibilities of the Warrantor under this warranty:

Repair or replace, at Warrantor's option, products or components which have failed within the duration of the warranty period.

Responsibilities of the purchaser under this warranty:

- A. Deliver or ship the *PushCorp, Inc.* product or component to PushCorp, Inc. Service Center, Dallas, TX. Freight and insurance costs, if any, must be borne by the purchaser.
- B. Use reasonable care in the operation and maintenance of the product as described in the owner's manual(s).

When warrantor will perform repair or replacement under this warranty:

Repair or replacement will be scheduled and serviced according to the normal work flow at the service center, and depending on the availability of replacement parts. Purchasers requiring quicker repair may receive such with payment of a *PushCorp, Inc.* predetermined expediting fee.

This Limited Warranty gives you specific legal rights and you may also have other rights which vary from state to state.

2.0 General Overview

The *PushCorp, Inc.* STC0325 High Torque Servo Tool Changer provides a convenient and effective means to spin and change many different media types. The unit incorporates a 25.0 horsepower (18.6 kW) Servo Motor to provide high torque and precise speed control from 0 to 3,000 RPM. The pneumatically clamped BT40 toolholder allows a quick change of media or tooling to support a fully automated workcell.

The STC0325 is comprised of five primary components: a high-torque Servo Motor, a 40 tapered & keyed shaft, a pneumatic actuator, high force Bellville springs, and a retention knob gripper assembly. The motor shaft is designed to accept a standard BT40 toolholder. Since the motor shaft is keyed and the toolholder has corresponding slots, they must be indexed to a known position before a tool change can occur. High force Bellville springs located at the back of the Motor Housing tension a draw bar, which pulls the gripper and locks the toolholder in the shaft. Energizing the large pneumatic actuator, located in the Clamping Housing opens the gripper assembly and releases the toolholder.

The STC0325 has several clever design features, which make it unique. First it is fail-safe in that no air pressure is required to secure the toolholder. Therefore the toolholder will remain held in the motor shaft even when the air pressure is unexpectedly lost. Likewise, applying air pressure to a single input port via a simple manual or electrically operated valve opens the retention knob gripper and releases the toolholder from the motor shaft. Finally, this mechanical design isolates the bearings from the drawbar tension. This greatly improves reliability by allowing the motor shaft to never be subjected to any clamping forces. The STC0325 has sealed duplex spindle bearings to insure a long life and very low runout. The front bearings have additional contamination protection from a PushCorp proprietary shaft seal. This special contact seal eliminates the need for constant purge air.

During operation the STC0325 generates considerable heat due to the high torque capability and compact size. Excessive operating temperatures will significantly reduce the life of the motor. The motor should never be allowed to exceed a temperature of 176 °F (80 °C). Continuously operating the unit above this value will cause the rotor to de-magnetize and the bearings to fail. High temperatures will also cause the O-rings that seal the cooling water to fail. PushCorp has provided flow through cooling on the motor to allow high duty cycles without overheating.

Simple reliable construction combined with high torque and precision speed controlled servo technology make the *PushCorp* STC0325 Servo Tool Changer a rugged, state-of-the-art technology capable of providing flexible, cost-effective tool changing operations.

3.0 Installation

3.1 Mounting the STC0325

3.1.1 Mounting to an AFD1200/90

The STC0325 Servo Tool Changer is designed to attach directly to the Carriage of a *PushCorp* AFD1200/90 Force Device in a Perpendicular-Axis configuration. The motor must mount as shown on the AFD carriage or rotated 180° to use the standard mounting holes.

To attach the STC0325 to an AFD in a Perpendicular-Axis configuration, position the Clamping Housing over the Carriage as shown in Figure 1. Then secure the unit using four (4), M8x1.25x250mm, Socket Head Cap Screws. Tighten the fasteners to the torque specified in Section 4.0.

CAUTION: Make sure that the M8x1.25 fasteners do not exceed a depth of 0.52" (13.3 mm) into the AFD Carriage Helicoils or damage will occur.

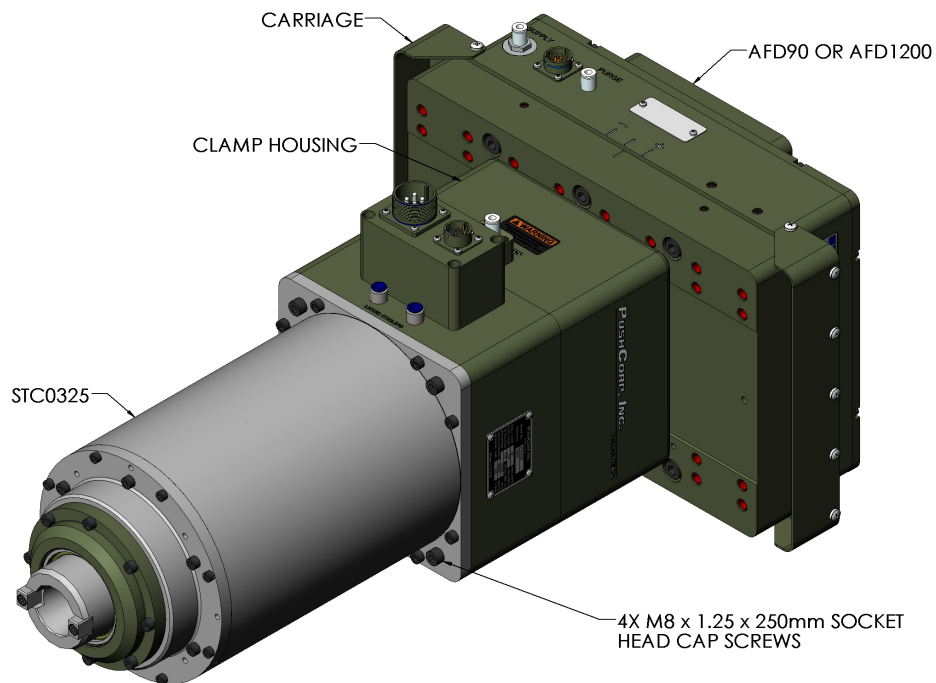

Figure 1. STC0325 Perpendicular-Axis Configuration

3.1.2 Mounting Directly to a Robot

For some processes compliance and force control are not required. The STC0325 can be mounted directly to the robot and the system can be operated in position mode. This robotic system is equivalent to a 5-axis machining center with a very large work volume and lower positional accuracy. Certain product types and processes are well suited for a Robotic Machining Center (RMC).

The STC0325 can be attached to the robot mounting flange using a mounting plate. For direct mounting it is recommended that a breakaway clutch be installed. The breakaway clutch will help protect the motor in the event of a robot crash. Loads on the motor shaft of over 5100 lb. (22700 N) radially and 2500 lb. (11120 N) axially will damage the spindle bearings.

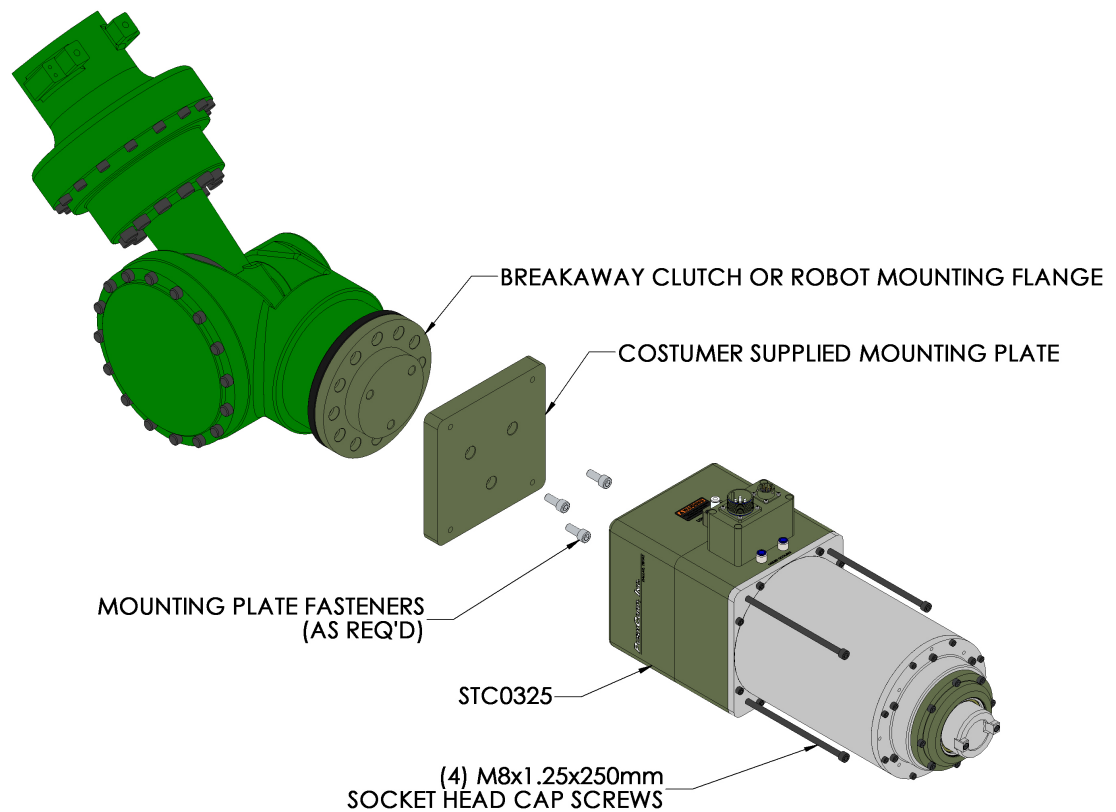

Figure 2. STC0325 Direct Mounting

To mount the STC0325, first attach the Mounting Plate to the Robot Mounting Flange or to the Breakaway Clutch, per the manufacturer's specifications. Once the Mounting Plate is secured, place the STC0325 against the Mounting Plate and install (4) four, M8x1.25X250mm, Socket Head Cap Screws. (See Figure 2.) Tighten the fasteners to the torque specified in Section 4.0.

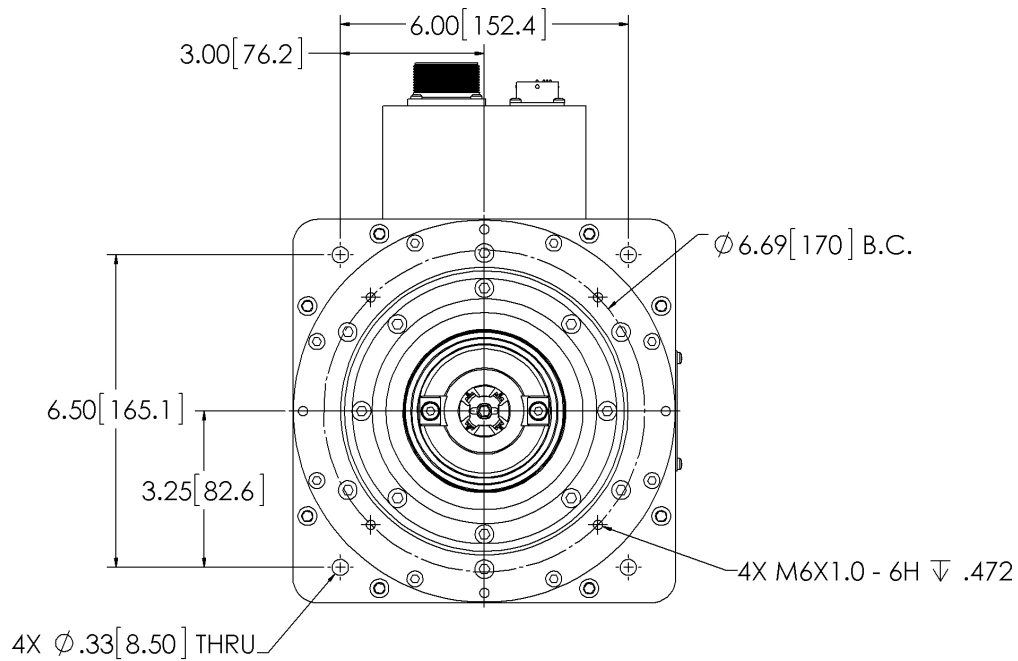

Figure 3. STC0325 Mounting Dimensions

3.2 Toolholder Specification

The STC0325 is designed to grip a BT40 toolholder. The BT40 toolholder is a standard machine tool style and may be purchased from several sources including, MSC (www.msc.com), and J & L Industrial Supply (www.jlindustrial.com). The Customer can also make their own BT40 toolholder to handle special media (See Figure 4 for toolholder dimensions). The toolholder must be equipped with a Parlec (www.parlec.com) retention knob, part number 4020TRK, or equivalent. Figure 5 shows the Parlec retention knob with the required dimensions.

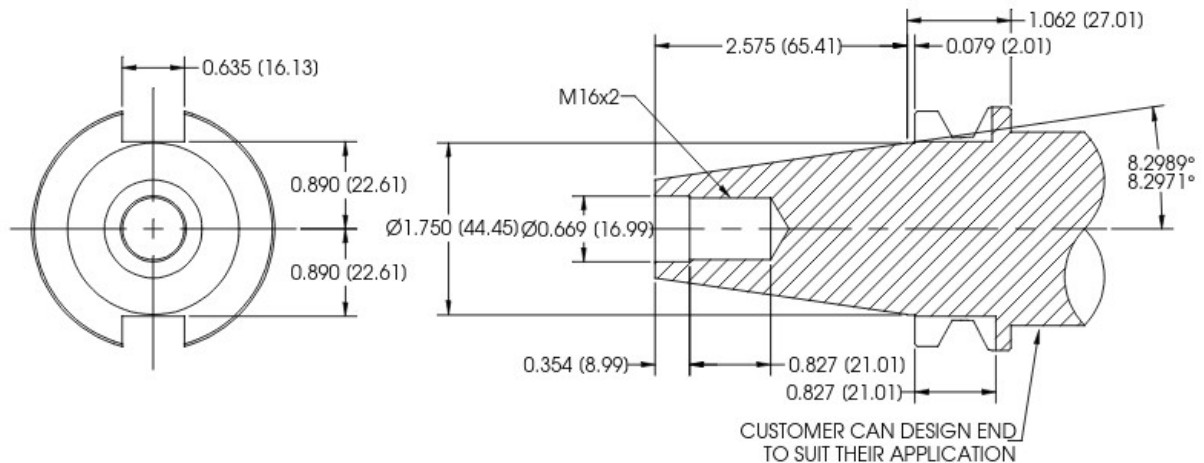

Figure 4. Toolholder Dimensions

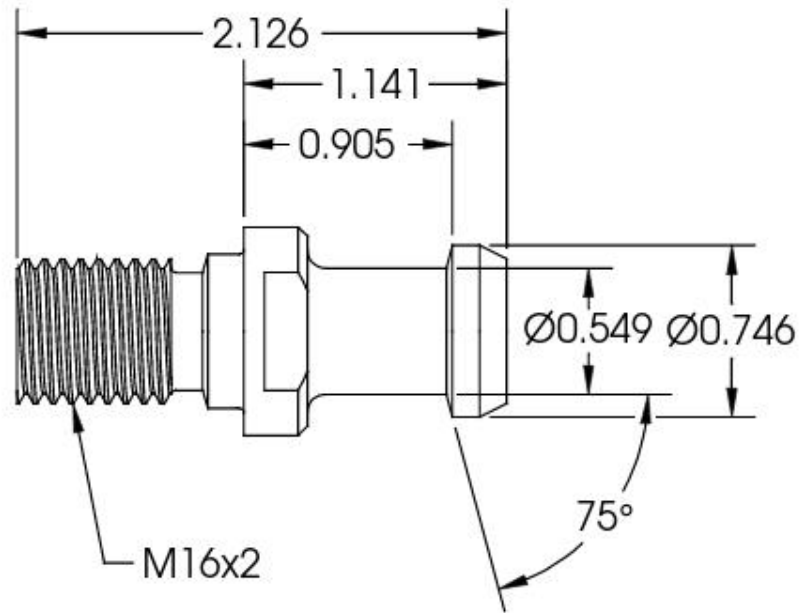

Figure 5. STC0325 Retention Knob

3.3 Pneumatic Connection

The STC0325 Servo Tool Changer requires a dry, non-lubricated, filtered air supply, with a minimum pressure of 90 psi (6.2 bar) and a maximum pressure of 100 psi (6.9 bar). Failure to provide supply air to these specifications can degrade performance and will void any warranty repairs concerning pneumatic components. If the supply air pressure is too low then the STC0325 will be unable to open the retention knob gripper fully. Not opening the retention knob gripper fully will not allow a toolholder to be clamped or released. Exceeding the maximum air pressure could result in permanent damage to the STC.

The pneumatic supply system should be configured as shown in Figure 6. A manual or electrically operated valve may be used to energize the STC0325 for toolholder release, but the valve must exhaust **ALL** line pressure when unenergized. An electrically operated pneumatic valve is normally used in an automated workcell. PushCorp highly recommends the installation of a Pressure Switch in the Supply Line to the STC0325. This switch should not allow the STC0325 to start if there is any pressure in the Supply Line. Pressure in the line will cause internal components to come into contact. This will either cause the motor not to spin, or cause very high internal friction, eventually friction welding components together.

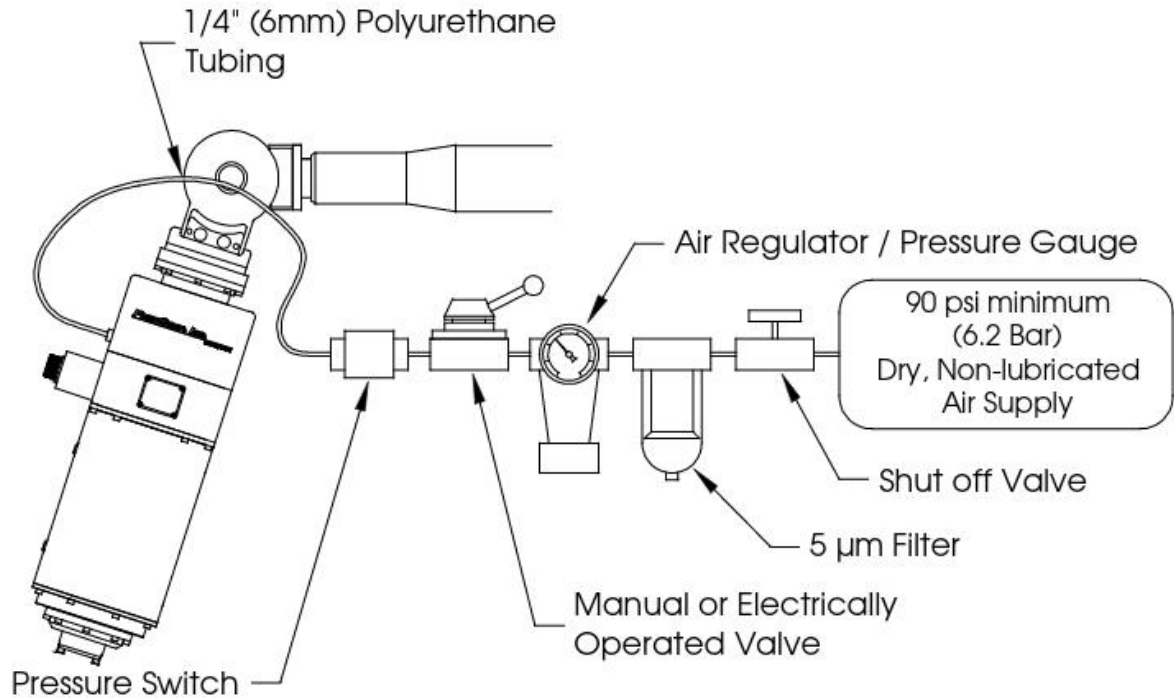

Figure 6. Pneumatic Connections

The STC0325 is provided with ¼ inch and 6 mm diameter tubing push-lock fittings for installation in the R 1/8 (Metric) Unclamp Port located on the top of the Clamping Housing (See Figure 8). Remove the shipping plug and install the desired size push-lock fitting. If another type of fitting is desired, unscrew the existing fitting and replace it with any fitting having an R 1/8 (Metric) thread. Be sure to use a thread seal product and do not over tighten the fitting.

The Supply Line to the device should be 1/4 inch or 6 mm diameter flexible polyurethane tubing. The tubing should be routed to the device such that there are no kinks and that there is plenty of slack to allow for manipulator motion. Before inserting the tubing into the STC0325 air fitting, open the Shut-Off Valve to blow out any contaminants which may be in the Supply Line. The tubing can now be pushed into the self-locking fitting located on the Clamping Housing as shown in Figure 8. Charge the Supply Line with compressed air and verify that there are no air leaks and that there is a minimum of 90 PSI (6.2 bar) at the STC0325. If a minimum air pressure cannot be achieved, then an auxiliary air compressor or booster pump must be installed.

NOTE: PushCorp highly recommends the use of flexible polyurethane tubing as opposed to nylon tubing. This is because nylon tubing tends to crimp shut when it is bent.

To remove the Supply Line for service, first discharge air pressure in the STC0325, then while pushing inward on the fitting's plastic ring, simultaneously pull the tubing out. Cover or plug the self-locking fitting any time the Supply Line is not connected. This will keep contaminants from entering the STC0325.

3.4 Electrical Connections

The STC0325 has two electrical connections, the Motor Power and Motor Feedback (See Figure 8). If PushCorp supplies the cables and amplifier the tool should be easily connected to the amplifier. If the customer wishes to use their own cables and/or amplifier the pin-outs for the Motor Power and Motor Feedback connectors are shown below in Figure 7. The release mechanism of the STC0325 relies solely on air pressure to operate; it requires no electrical connections.

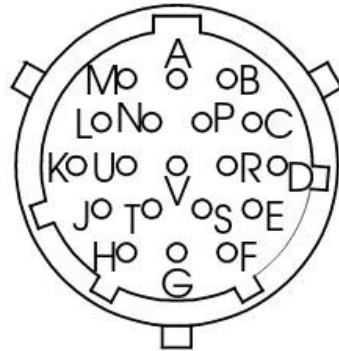

FEEDBACK CONNECTOR

FEEDBACK PIN-OUTS

PIN	SIGNAL
A	EXCITATION R1
B	EXCITATION R2
C	COSINE S1
D	SINE S2
E	COSINE S3
F	SINE S4
T	THERMAL SWITCH
U	THERMAL SWITCH
V	SHIELD

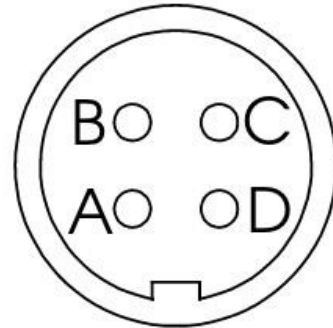

POWER CONNECTOR

POWER PIN-OUTS

PIN	SIGNAL
A	PHASE U
B	PHASE V
C	PHASE W
D	GROUND/SHIELD

Figure 7. Electrical Connector Pin-outs

CAUTION: Do not run the Motor Power Cable together with any feedback or control cables because of possible noise problems.

3.5 Motor Cooling

The STC0325 has a compact, high torque, 25.0 Hp (18.6 kW) Servo Motor which requires water cooling. The motor is designed to operate below a temperature of 176 °F (80 °C). The optimal motor temperature range is 122 – 140 °F (50 – 60 °C). The STC0325 contains cooling channels in the Inter Housing that connect to the stator. These channels allow efficient removal of the heat. The coolant enters and exits the Inter Housing through two Motor Cooling Ports as shown in Figure 8. Either of these Motor Cooling Ports can be used as an input, the other would then become an output.

A closed-loop water cooling system must be used and requires a separate cooling unit that circulates water through the Motor Housing to remove the heat. All of the coolant is recirculated in the system, and no continuous supply or discharge is required. A mixture of pure distilled water and a corrosion inhibitor is required such as DowTherm SR-1, or equivalent. Typical cooling units are comprised of a pump, water to air heat exchanger, and fan. These units are commercially available from several manufacturers (eg Miller Coolmate 3, www.millerwelds.com). The cooling unit should be sized based on the motor power output of 25 Hp (18.6 kW) with an overall motor efficiency of 90% and the motor load conditions. Again it is recommended to closely monitor the motor temperature during actual production operation to ensure that it does not overheat.

NOTE: The life of the STC0325 motor is directly related to the operational temperature, so proper cooling is critical.

The STC0325 is supplied with two 5/16” and 8 mm diameter tube push-lock fittings for installation in the Motor Cooling Ports. Remove the shipping plugs and install the desired size push-lock fittings. If another type of fitting is desired, replace the existing fitting with a fitting having an R 1/4 (Metric) thread (STC0325’s previous to SN62005 have an R 1/8 (Metric) thread). Be sure to use a thread seal product and do not over tighten the fitting.

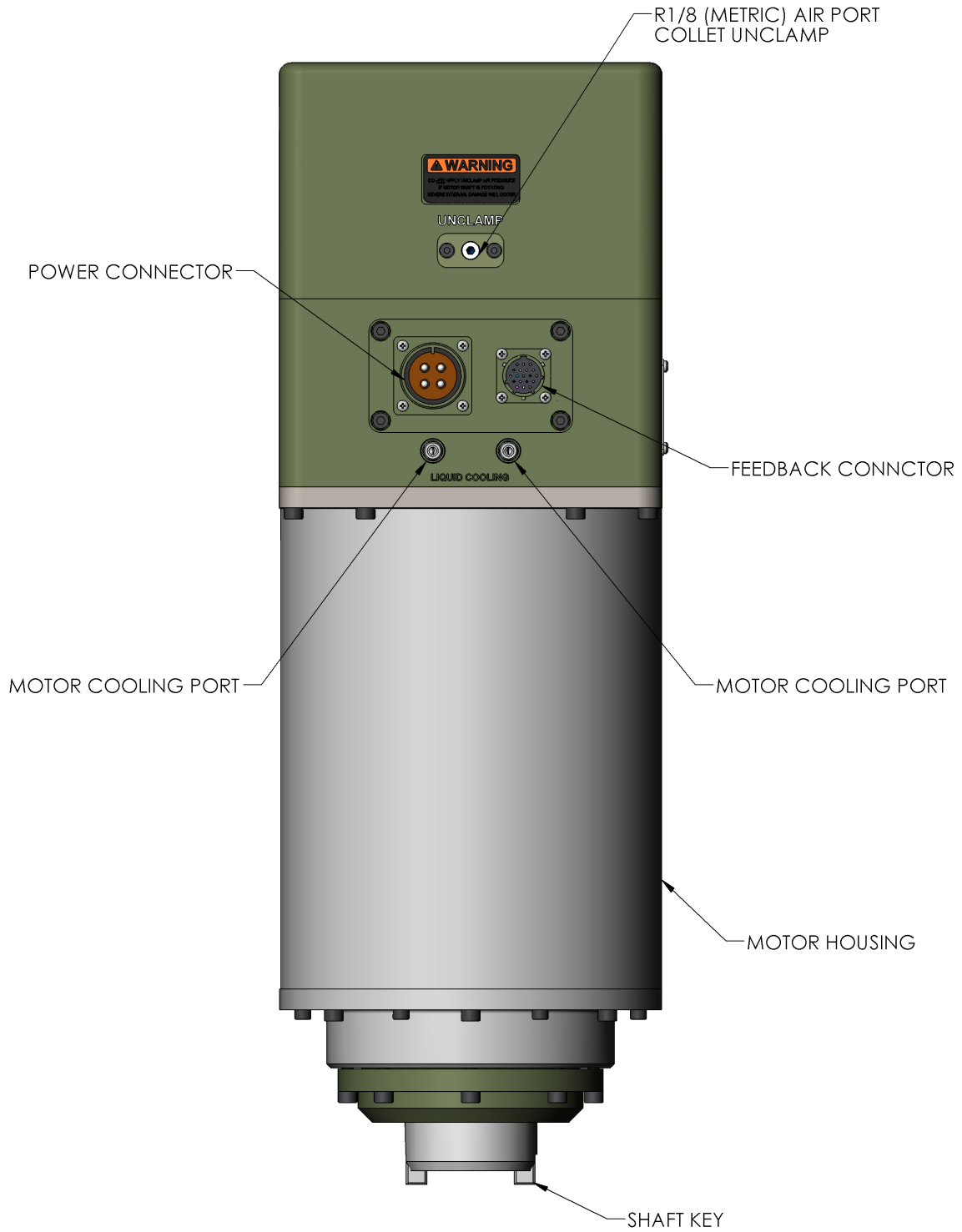

Figure 8. STC0325 External Connections

3.7 Monitoring Motor Temperature

The STC0325 is designed to operate below a temperature of 176 °F (80 °C) and within an optimal range of 122-140 °F (50-60 °C). The motor contains a thermal cutoff switch. If the temperature exceeds 212 °F (100 °C) the motor will stop running until it has cooled off. This feature should not be used to control the motor temperature. The thermal cutoff is designed to operate only when all other precautions have failed.

3.8 Motor Acceleration/Deceleration

Servo Motors have the ability to start and stop very quickly. As long as the motor does not overheat or the amplifier exceed the allowable current input, the motor will continue to operate. The problem is that the motor and amplifier can experience excessive current spikes with rapid acceleration and deceleration. Media or tooling with a large mass or large diameter (i.e., high moment of inertia) only increases the current surge. The amount of time allowed to reach the desired speed or stop will directly effect the life of the motor. PushCorp recommends a smooth, linear velocity ramp with a *minimum* period of one second be used to accelerate to full speed or to decelerate to zero speed. The minimum one-second-acceleration period must be increased if larger, higher inertia tools are used to prevent servo amplifier faults and avoid long-term damage.

3.8 Positioning Motor Shaft for Tool Change

When performing a tool change the motor shaft must be clocked in the same position for drop-off and pick-up. The servo motor shaft has two keys (See Figure 8) that are spaced 180° apart and the BT40 toolholder has two corresponding key slots. The Parvex amplifier provides an input to clock the motor shaft in the proper position.

4.0 Technical Specifications

MOTOR SPECIFICATIONS:

Power: 25.0 hp (18.6 kW)
 Continuous Stall Torque: 36.9 lb.-ft. (50 N·m)
 Maximum Speed: 3000 RPM, Reversible
 Speed Regulation: $\pm 2\%$
 Weight: 180 lb. (82 kg) Dry
 Operating Temperature: Optimal: 122 – 140 °F (50 – 60 °C)
 Maximum: 176 °F (80 °C)
 Thermal Cutoff: 212 °F (100 °C)
 Max. Coolant Pressure: 60 psi (4.1 Bar)

TOOLHOLDER SPECIFICATIONS:

Toolholder: BT40 standard

Retention Knob: Parlec #4020TRK, or equivalent

Clamping Supply Air:

Dry, Non-lubricated, 90 psi (6.2 bar) Min., 100 psi (6.9 bar) Max.
 Requires power amplifier and cables.
 For specific dimensions see www.pushcorp.com for detail drawings.

Specifications subject to change without notice.

Fastener Tightening Torque Specs					
Fastener Size	Torque			Minimum Depth	
	in.-lbs.	ft.-lbs.	N·m	in.	mm
M4 x .7	50	4.2	5.6	0.17	4.3
M5 x .8	85	7.1	9.6	0.21	5.3
M6 x 1	140	11.7	15.8	0.25	6.3
M8 x 1.25	348	29.0	39.3	0.33	8.4
M10 x 1.5	600	50.0	67.8	0.41	10.5

5.0 Preventative Maintenance Schedule

It is highly recommended to adhere to the preventative maintenance schedule in order help extend the longevity of the specified PushCorp, Inc. equipment. Failing to do so could cause a loss in functionality as well as a decrease in product life.

PUSHCORP, INC. SPINDLES			
Maintenance	Weekly	Monthly	3 Months
Remove chips from the ID of the shaft	X		
Remove debris from spindle/spindle housing	X		
Check that the connectors are not bent/damaged	X		
Check for flow in the motor cooling and unclamp ports		X	

Agency/Organization: _____

Date Completed: _____