

**NICOR<sup>®</sup>**



**USL** LED String Light



# USL

## LED String Light

The NICOR USL LED string light offers bright, reliable illumination for construction sites, workshops, temporary setups, and outdoor use. Replacing traditional incandescent lights, it provides efficient, even light, reducing power costs. Its rugged, impact- and UV-resistant housing with hanging hooks allows quick, flexible installation in tough environments. Weather-resistant and suitable for indoor or outdoor use, multiple strands can be linked for larger areas. Long-lasting LEDs cut maintenance and downtime. Easy to set up with plug-and-play operation, it is ideal for temporary and utility lighting.

### Dimensions

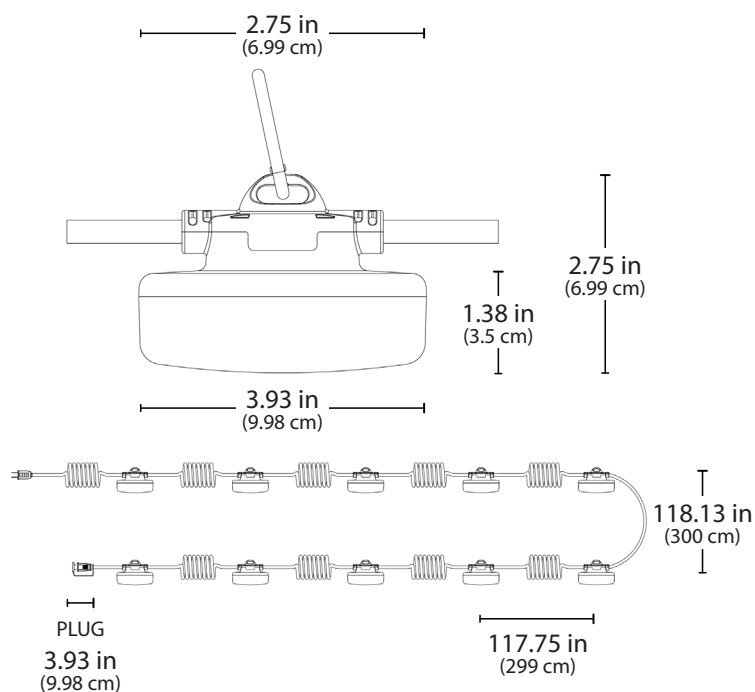

## FEATURES



### Linkable Design

- Connect up to 3 units for a 300 ft of coverage



### Easy Installation

Includes snap-lock carabiner at each head that allows a secure, toolless installation.

### Industrial-grade Construction

Built to withstand dust and moisture, suitable for both indoor and outdoor use.



**CRI**  
>80



**Lumens**  
15,295



**Lifetime**  
>18,000 hrs



**Beam Angle**  
130°

| Ordering Information |         |             |            |               |         |           | Example: USL110018212085YL |  |
|----------------------|---------|-------------|------------|---------------|---------|-----------|----------------------------|--|
| Series               | Version | Length (ft) | Wire Type  | Input Voltage | CRI     | CCT       | Finish Color               |  |
| USL                  | 1       | 100         | 182 (18/2) | 120 (120VAC)  | 8 (80+) | 5 (5000K) | YL (Yellow)                |  |

Specifications and dimensions subject to change without notice. Please refer to the website for the most up-to-date information.



NICOR Lighting  
2200 Midtown Place NE  
Albuquerque, NM 87107 USA

20251220  
©2026 NICOR® | ALL RIGHTS RESERVED

**Warehouse Locations**  
Albuquerque, NM  
Buford, GA  
Roseville, CA

**T. 800-821-6283**  
F. 800-892-8393  
[www.nicorlighting.com](http://www.nicorlighting.com)

