

Thank you for choosing this quality product. Be sure to check all packaging materials carefully for small parts that may have become loose during shipment and place all parts on a non-abrasive surface.

IMPORTANT : These parts can be cumbersome and heavy to some people, therefore the assistance of two or more people is recommended in order to prevent personal injury and ensure the furniture is not damaged during the assembly Process.

CARE INSTRUCTIONS

1. Dust often using a clean, soft, dry and lint-free cloth.
2. Blot spills immediately and wipe with a clean, damp, cloth.
3. We do not recommend the use of chemical cleansers, abrasives or furniture polish on our lacquered finish.





PART LIST

A [1] TABLETOP

B [1] TABLEBASE (LARGE)

C [1] TABLEBASE (SMALL)

HARDWARE LIST

NO	DESCRIPTION	QTY
1	 ALLEN HEAD BOLT M8X40MM	8
2	 LOCK WASHER	8
3	 PLAIN WASHER	8
4	 ALLEN WRENCH	1

INSTRUCTIONS

1. Preset the both of table bases (B/ C) on your desired location. Distance between the top panels of the bases should be 134mm. See FIGURE 01.
2. Bring the table top (A) and set it on the assembled base. Align the fixed nuts at the bottom of the top to the holes on top of the base. Insert Allen bolts (1) together with Lock washers (2) and Flat washers (3) into each fixed nuts through the holes on top of the base, then tighten them by using Allen key (4). DO NOT OVERTIGHTEN. See FIGURE 02.
3. Assembly is complete.

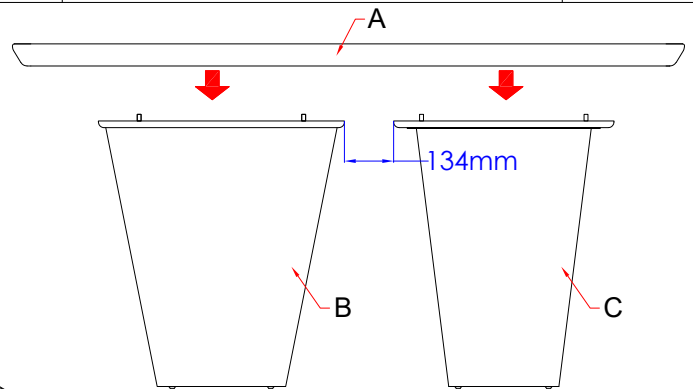

FIGURE 01

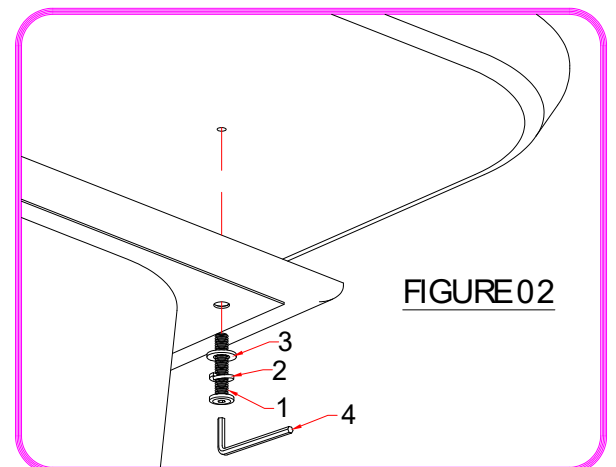
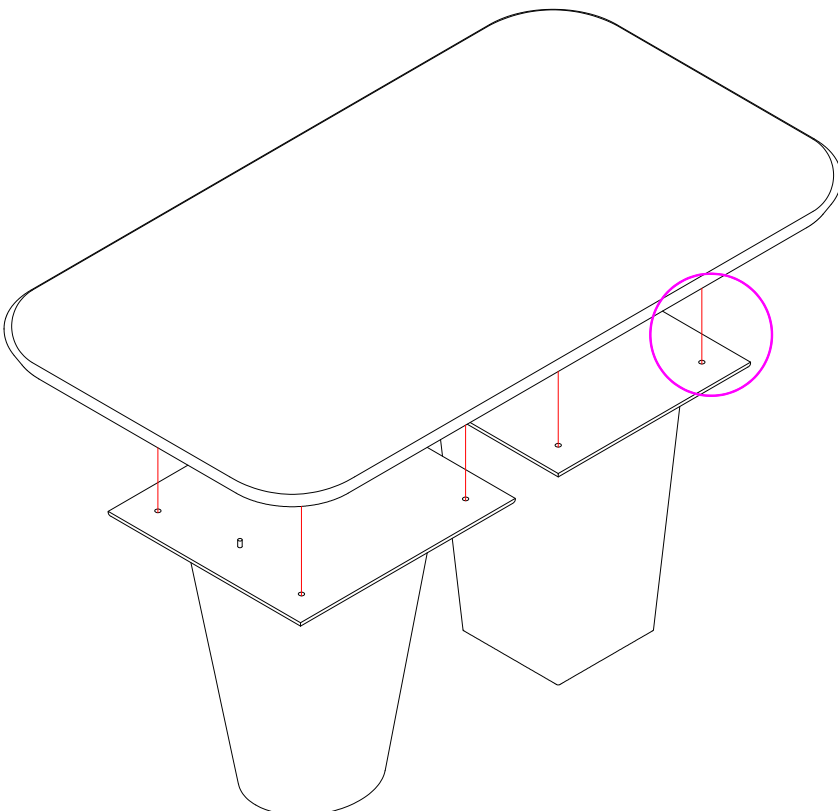

FIGURE 02