

NOTES:
 1. MATERIAL: TPE
 2. COLOR: GRAY

CUSTOMER DRAWING

This drawing is the property of Rev-A-Shelf (RAS) and is disclosed in confidence to the extent its subject matter is original to RAS. Any vendor receiving this drawing from RAS shall hold and use this drawing for the sole benefit of RAS and shall not disclose it to, or use or reproduce it for any third party, or perform any act adverse to the interest of RAS with respect to this drawing without the express written permission of RAS. Vendors shall not revise any physical, dimensional or performance characteristic unless authorized by Rev-A-Shelf Engineering.

SECTION A-A

REV.	DATE	BY	DESCRIPTION OF CHANGE

INCH [MM]	AMERICAN PROJECTION	DRAWN	BY	DATE	REV-A-SHELF, INC.
			KRR	1-9-23	
TOLERANCES			MATERIAL	DRAWING NO.	SCALE
MAT.	DEC.	ANGLES		SBVDTF-2730-14-1	0.250
(WOOD) .XX ±.03 [8mm]	(OTHER) .XX ±.02 [5mm]	±1/2°	FINISH	PART NO.	SHEET OF
(ALL) .XXX ±.005 [13 mm]	FRACTIONS ±1/32 [8 mm]			SBVDTF-2730-14-1	1 2

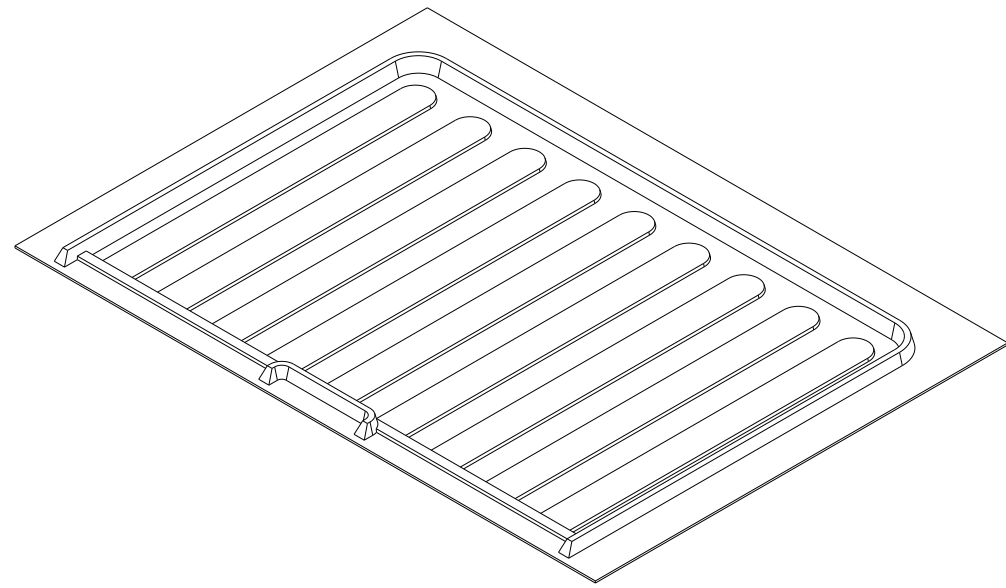

PART DIMENSIONS		
	MIN	MAX
WIDTH	25.50	28.50
DEPTH	18.50	20.25
HEIGHT	.72	.72
WEIGHT		
DIAMETER		
RADIUS		
CONTAINER CAPACITY	1.23	
CONTAINER UOM	QUARTS	

MIN CABINET OPENING	
WIDTH	-
DEPTH	-
HEIGHT	-

CUSTOMER DRAWING

This drawing is the property of Rev-A-Shelf (RAS) and is disclosed in confidence to the extent its subject matter is original to RAS. Any vendor receiving this drawing from RAS shall hold and use this drawing for the sole benefit of RAS and shall not disclose it to, or use or reproduce it for any third party, or perform any act adverse to the interest of RAS with respect to this drawing without the express written permission of RAS. Vendors shall not revise any physical, dimensional or performance characteristic unless authorized by Rev-A-Shelf Engineering.

REV.	DATE	BY	DESCRIPTION OF CHANGE

INCH [MM]	AMERICAN PROJECTION 	DRAWN	BY	DATE	REV-A-SHELF, INC.
		KRR	KRR	10-18-11	
TOLERANCES		ANGLES ±1/2°	MATERIAL	DRAWING NO.	SCALE
MAT.	DEC.		FINISH	SBVDTF-2730-14-1-CUST	0.150
(WOOD) .XX ±.03 [.8mm]	(OTHER) .XX ±.02 [.5mm]		PART NO.	SEE SHT. 1	SHEET OF
(ALL) .XXX ±.005 [.13 mm]	FRACTIONS ±1/32 [.8 mm]				2 OF 2