

CUSTOMER DRAWING

This drawing is the property of Rev-A-Shelf (RAS) and is disclosed in confidence to the extent its subject matter is original to RAS. Any vendor receiving this drawing from RAS shall hold and use this drawing for the sole benefit of RAS and shall not disclose it to, or use or reproduce it for any third party, or perform any act adverse to the interest of RAS with respect to this drawing without the express written permission of RAS. Vendors shall not revise any physical, dimensional or performance characteristic unless authorized by Rev-A-Shelf Engineering.

| REV. | DATE | BY | DESCRIPTION OF CHANGE |
|------|------|----|-----------------------|
| | | | |
| | | | |
| | | | |

| | | | | | | |
|--------------------------------|----------------------------|---------------------------|----------|------------------|-------------------|----------------------|
| INCH [MM] | AMERICAN PROJECTION | DRAWN | BY | DATE | REV-A-SHELF, INC. | |
| | | | KRR | 1-2-23 | SIZE B | DOUBLE 27QT PULL OUT |
| TOLERANCES | | ANGLES $\pm 1/2^\circ$ | MATERIAL | DRAWING NO. | SCALE | |
| MAT. | DEC. | | FINISH | 4VLWCSC-1527DM-2 | 0.200 | |
| (WOOD) .XX \pm .03 [.8mm] | | | | PART NO. | SHEET OF | |
| (OTHER) .XX \pm .02 [.5mm] | | | | 4VLWCSC-1527DM-2 | 1 | 2 |
| (ALL) .XXX \pm .005 [.13 mm] | | | | | | |
| FRACTIONS $\pm 1/32$ [.8 mm] | | | | | | |

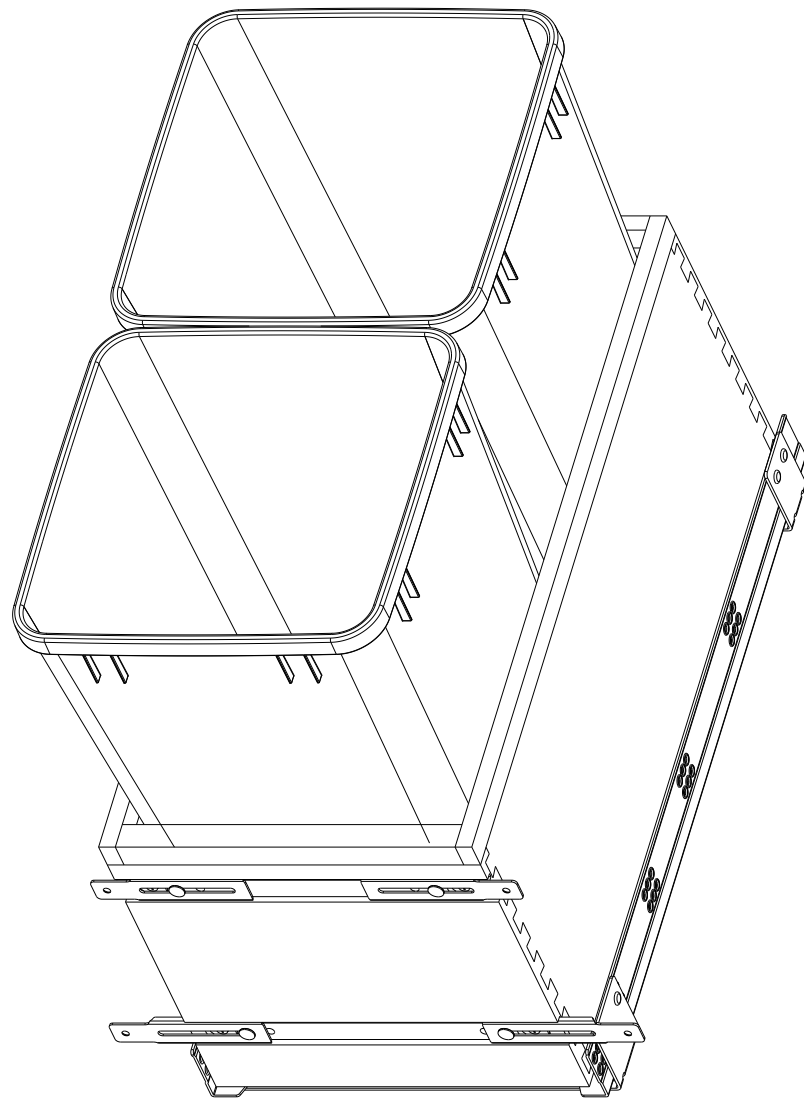

| PART DIMENSIONS | | |
|--------------------|-------|-----|
| | MIN | MAX |
| WIDTH | 11.50 | |
| DEPTH | 21.50 | |
| HEIGHT | 19.54 | |
| CONTAINER CAPACITY | 27 | |
| CONTAINER UOM | QUART | |

| MIN CABINET OPENING | | | | |
|---------------------|------------|-----------|------------------|-----------------|
| | FACE FRAME | FRAMELESS | INSET FACE FRAME | INSET FRAMELESS |
| WIDTH | 11.50 | 11.50 | 11.50 | 11.50 |
| DEPTH | 21.75 | 21.75 | 22.50 | 22.50 |
| HEIGHT | 20.00 | 20.00 | 20.00 | 20.00 |

| SLIDE SPECIFICATIONS | | | | |
|----------------------|-------------|---------------------|---------------|-------------------|
| SLIDE MANUFACTURER | BTL | | | |
| SLIDE PART NUMBER | BC1A-16-533 | RELEASE PART NUMBER | | |
| SLIDE TYPE | UNDERMOUNT | SLIDE EXTENSION | FULL | MAX WEIGHT RATING |
| SLIDE CLOSING | SOFT/SELF | SLIDE LENGTH | 21.00 [533MM] | |
| SLIDE MOUNTING | BOTTOM | SLIDE FINISH | ZINC | 75 |

CUSTOMER DRAWING

This drawing is the property of Rev-A-Shelf (RAS) and is disclosed in confidence to the extent its subject matter is original to RAS. Any vendor receiving this drawing from RAS shall hold and use this drawing for the sole benefit of RAS and shall not disclose it to, or use or reproduce it for any third party, or perform any act adverse to the interest of RAS with respect to this drawing without the express written permission of RAS. Vendors shall not revise any physical, dimensional or performance characteristic unless authorized by Rev-A-Shelf Engineering.

| REV. | DATE | BY | DESCRIPTION OF CHANGE |
|------|------|----|-----------------------|
| | | | |
| | | | |
| | | | |

| | | | | | |
|-----------|---------------------|-------|----------|----------------------|-------------------|
| INCH [MM] | AMERICAN PROJECTION | DRAWN | BY | DATE | REV-A-SHELF, INC. |
| | | | KRR | 1-2-23 | |
| | | | SIZE | DOUBLE 27QT PULL OUT | |
| | | | MATERIAL | DRAWING NO. | SCALE |
| | | | FINISH | 4VLWCSC-1527DM-2 | 0.200 |
| | | | | 4VLWCSC-1527DM-2 | PART NO. |
| | | | | 4VLWCSC-1527DM-2 | 2 OF 2 |

TOLERANCES
 MAT. DEC.
 (WOOD) .XX ±.03 [.8mm]
 (OTHER) .XX ±.02 [.5mm]
 (ALL) .XXX ±.005 [.13 mm]
 FRACTIONS ±1/32 [.8 mm]

ANGLES ±1/2°