

INSTALLATION INSTRUCTIONS

5322 SERIES BASE ORGANIZER

TOOLS REQUIRED:

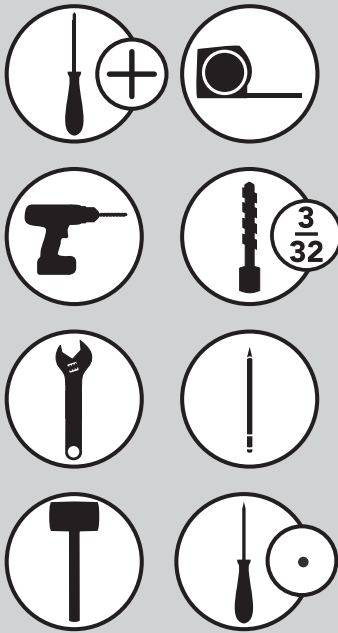

ESTIMATED ASSEMBLY TIME:

15 MIN

CARE AND MAINTENANCE:

Clean with a damp cloth and wipe parts dry.



Parts List

No.	Description	Qty
1	Chassis	1
2	Slide Set	2
3	Shelf Support	2
4	Side Mount Brackets	2
5	Template	1
6	Double-Sided Tape	4
7	M4 x 10MM Screws	6
8	#6 x 1/2" Screws	6
9	#8 x 1/2" Screws	6
10	Euro Screws	6

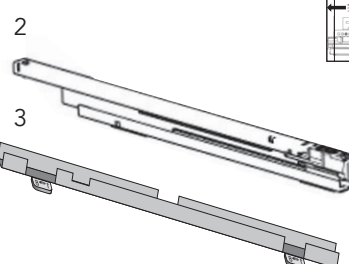
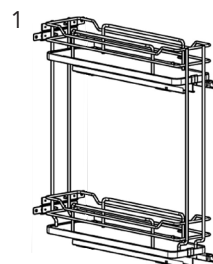
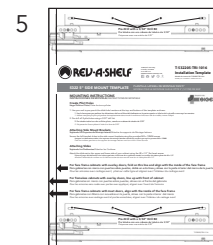
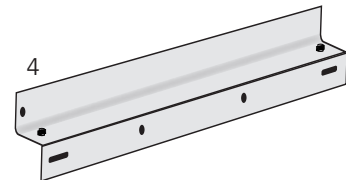

STEP 1

Install the slides to the wall of the cabinet using the template provided (See Figure 1).

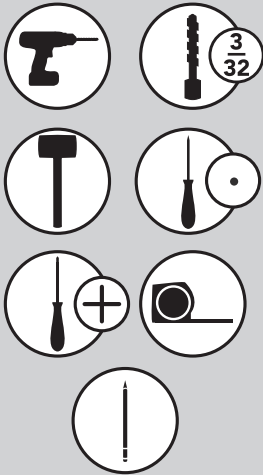
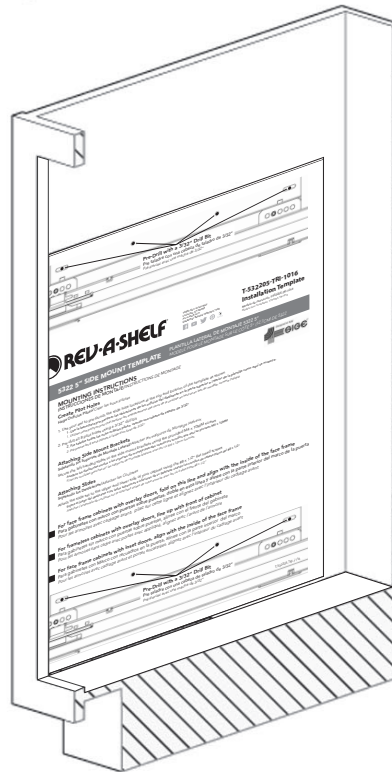

FIGURE 1



STEP 2

Attach the plastic clips onto the shelf supports and install them to the underside of each shelf using the provided Euro screws, as shown in Figure 2.1.

NOTE: the plastic clips must be attached as shown in Figure 2.2; The orientation of the number "18" is critical.



FIGURE 2.1

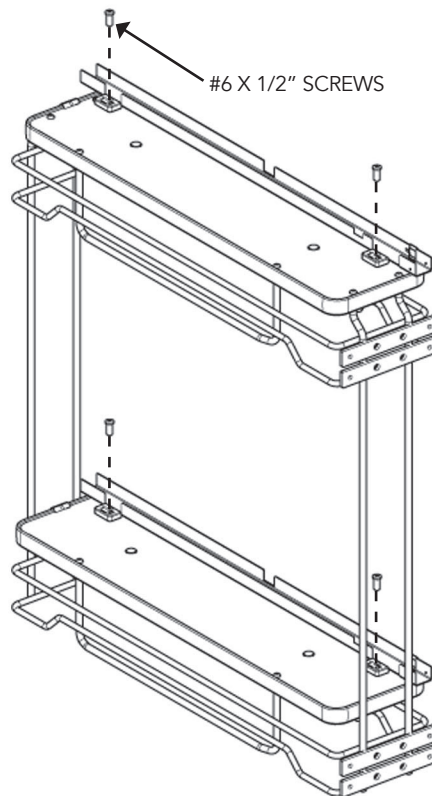
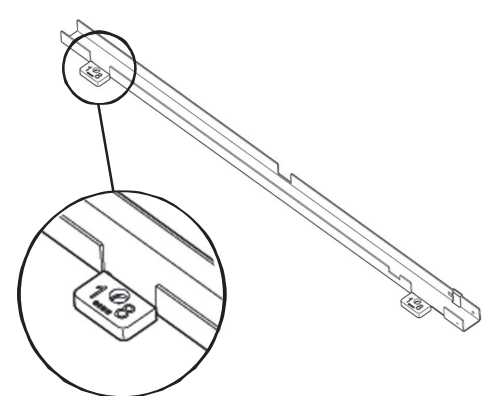

FIGURE 2.2



STEP 3

Ensure that the slides are fully extended. Install the basket assembly on both sides at the same time, starting with the rear first, then clicking the front of the slides into place (See Figure 3).

FIGURE 3

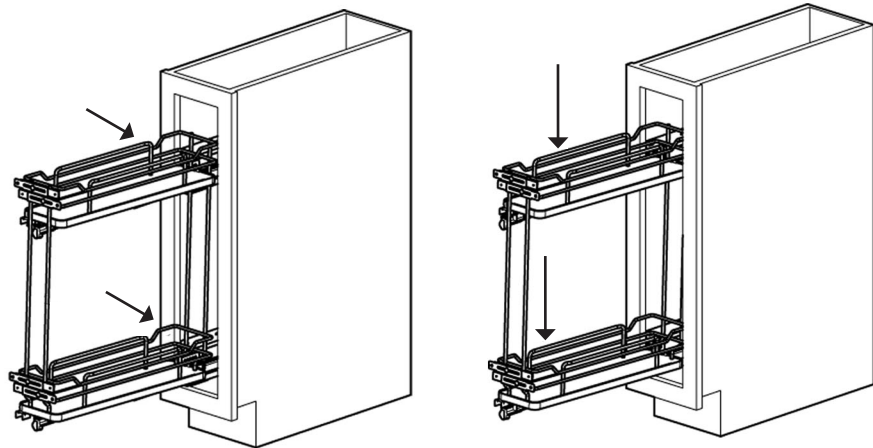

STEP 4

Setting up the Brackets

Ensure that all holes pre-drilled for door mounting are done at the center of the thick part of your door. (See Figure 4.1)

Finding Hole Locations

Refer to Figure 4.2 to determine door mounting hole locations. Transfer these dimensions to your door from the bottom and mark where the holes should be. Pre-drill these hole locations with a 3/32 drill bit. Be sure to not drill all the way through the door.

Securing the Brackets

Align the door mount bracket with the pre-drilled holes in your door. Secure your door to the door mount bracket and door mount support brackets with the #6x1/2" screws. Use the adjustable door mount bracket extension pieces to align horizontally.

NOTE: Refer to Step 5 for an alternate method

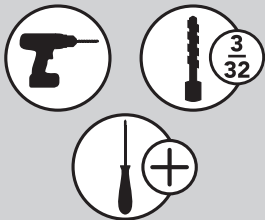

FIGURE 4.1

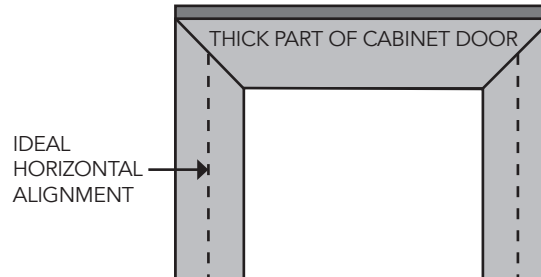

FIGURE 4.2

<p>Top Bracket</p> <p>1. Measure from cabinet opening to top bracket slot _____</p> <p>Measure from cabinet opening to bottom bracket slot _____</p>	<p>Bottom Bracket</p> <p>Measure from cabinet opening to top bracket slot _____</p> <p>Measure from cabinet opening to bottom bracket slot _____</p>						
<p>(a) (b)</p>							
<p>2. Measure Cabinet Opening Height (a) _____</p> <p>Measure Door Height (b) _____</p> <p>Height Difference _____</p> <p>Divide Difference by 2 _____</p>	<p>3. If your door is larger than cabinet opening, add the divided difference you found in step 2 to the measurements in step 1. If your door is smaller, subtract the divided difference from the measurements in step 1.</p> <table border="0"> <tr> <td>Top Bracket</td> <td>Bottom Bracket</td> </tr> <tr> <td>Top Measurement _____</td> <td>Top Measurement _____</td> </tr> <tr> <td>Bottom Measurement _____</td> <td>Bottom Measurement _____</td> </tr> </table>	Top Bracket	Bottom Bracket	Top Measurement _____	Top Measurement _____	Bottom Measurement _____	Bottom Measurement _____
Top Bracket	Bottom Bracket						
Top Measurement _____	Top Measurement _____						
Bottom Measurement _____	Bottom Measurement _____						

STEP 5

Apply double stick tape to the door mount brackets as shown in Figure 5.1. Attach cabinet door to the brackets while trying to keep door level. Double stick tape will hold the door in place while you screw the brackets to the cabinet door. (See Figure 5.2)

NOTE: Although this method is the quickest and easiest method to attach the door, it does limit adjustability since the door will become adhered to the brackets

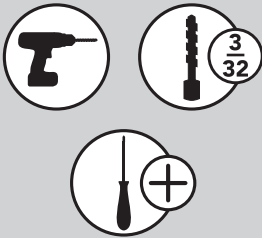

FIGURE 5.1

PLACE DOUBLE-SIDED TAPE TO OVER DOOR MOUNT BRACKETS

NOTE: AT THIS TIME, ENSURE YOUR DOOR IS VERTICALLY ALIGNED AS DESIRED

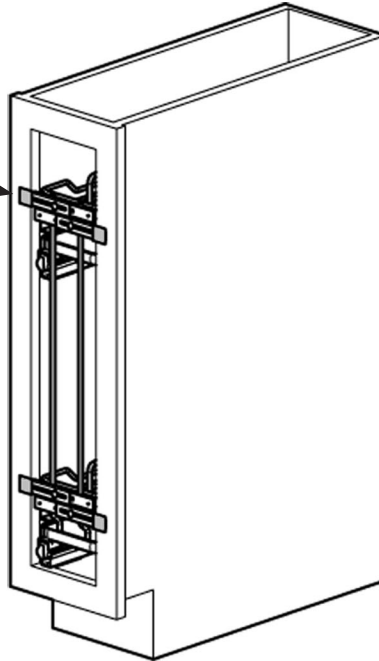
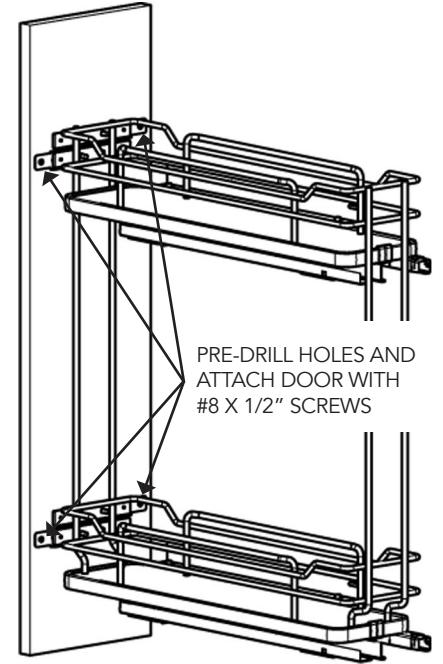

FIGURE 5.2

PRE-DRILL HOLES AND ATTACH DOOR WITH #8 X 1/2" SCREWS



STEP 5

Loosen the two nuts on both door mount locations as shown in Figures 6.1 and 6.2 ((4) nuts total) to adjust unit horizontally. Once your door is correctly adjusted, re-tighten the nuts on both door mount locations.



FIGURE 6.1

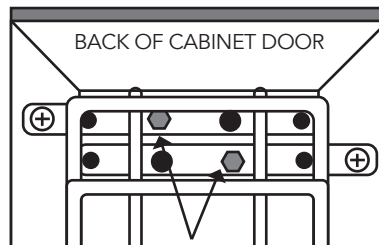

BACK OF CABINET DOOR
LOOSEN THE 2 NUTS ON BOTH DOOR MOUNT LOCATIONS (4 NUTS TOTAL) TO ADJUST HORIZONTALLY

FIGURE 6.2



NUT LOCATIONS



12400 Earl Jones Way
Louisville, KY 40299
rev-a-shelf.com
Customer Service: 800-626-1126