

# ***S724 with EIP***

## **Servo Control Cabinet**

### **Model**

### **SMFBCON5-EIP**



***PUSHCORP, INC.***

---

**Dallas, Texas**

## **Table of Contents**

<b>1.0 LIMITED WARRANTY.....</b>	<b>2</b>
<b>2.0 GENERAL OVERVIEW.....</b>	<b>4</b>
<b>3.0 INSTALLATION.....</b>	<b>4</b>
3.1 Cabinet Mounting.....	4
3.2 Electrical Connections.....	5
<b>4.0 PROGRAMMING PORT.....</b>	<b>7</b>
<b>5.0 IP ADDRESS ASSIGNMENT.....</b>	<b>7</b>
5.1 Changing IP Addresses.....	8
5.1.1 Software-based Configuration.....	8
5.1.2 Web-based Configuration.....	8
5.2 Ethernet IP EDS File Information.....	8
5.2.1 Axio Coupler Configuration.....	8
5.2.2 FCUFLEX Anybus Configuration.....	8
5.3 – Component I/O Mapping.....	9
5.3.1 Axio Coupler I/O Map.....	9
5.3.1 FCUFLEX I/O Map.....	15
<b>6.0 TECHNICAL SPECIFICATIONS AND SCHEMATICS.....</b>	<b>18</b>
<b>7.0 SPARE REPLACEMENT PARTS.....</b>	<b>19</b>

## 1.0 Limited Warranty

### Duration:

One year from date of delivery to the original purchaser.

### Who gives this warranty (warrantor):

*PushCorp, Inc.*

Telephone: (972) 840-0208

Corporate Address:

P. O. Box 181915

Dallas, Texas 75218

Shipping Address:

3001 W. Kingsley Rd.

Garland, Texas 75041

### Who receives this warranty (purchaser):

The original purchaser (other than for purposes of resale) of the *PushCorp, Inc.* product

### What products are covered by this warranty:

Any *PushCorp, Inc.* Adjustable Force Device or Adjustable Force Device accessory supplied or manufactured by the Warrantor.

### What is covered under this warranty:

Defects in material and/or workmanship which occur within the duration of the warranty period.

### What is NOT covered in this warranty:

- A. IMPLIED WARRANTIES, INCLUDING THOSE OF MERCHANT-ABILITY AND FITNESS FOR A PARTICULAR PURPOSE ARE LIMITED TO ONE YEAR FROM THE DATE OF ORIGINAL PURCHASE. Some states do not allow limitations on how long an implied warranty lasts, so the above limitations may not apply to you.
- B. ANY INCIDENTAL, INDIRECT, OR CONSEQUENTIAL LOSS, DAMAGE or EXPENSE THAT MAY RESULT FROM ANY DEFECT, FAILURE, MALFUNCTION OF THE *PUSHCORP, INC.* PRODUCT. Some states do not allow the exclusion or limitation of incidental or consequential damages so the above limitation or exclusion may not apply to you.
- C. Any failure that results from an accident, purchaser's abuse, neglect, unauthorized repair or failure to operate the products in accordance with the instructions provided in the owner's manual(s) supplied with the product.

### Responsibilities of the Warrantor under this warranty:

Repair or replace, at Warrantor's option, products or components which have failed within the duration of the warranty period.

**Responsibilities of the purchaser under this warranty:**

- A. Deliver or ship the *PushCorp, Inc.* product or component to PushCorp, Inc. Service Center, Dallas, TX. Freight and insurance costs, if any, must be borne by the purchaser.
- B. Use reasonable care in the operation and maintenance of the product as described in the owner's manual(s).

**When warrantor will perform repair or replacement under this warranty:**

Repair or replacement will be scheduled and serviced according to the normal work flow at the service center, and depending on the availability of replacement parts. Purchasers requiring quicker repair may receive such with payment of a *PushCorp, Inc.* predetermined expediting fee.

This Limited Warranty gives you specific legal rights and you may also have other rights which vary from state to state.

## 2.0 General Overview

The *PushCorp* S724 control cabinets provide a highly integrated, easy to use solution to controlling *PushCorp* servomotor and compliance equipment. Installation is simply a matter of mounting the cabinet and connecting 3-phase, 480VAC, electrical power, connecting the safety inputs/outputs and a single ethernet connection. The S724 Control Console allows the equipment to be controlled via a remote PLC or robot controller using an Ethernet IP fieldbus connection.

## 3.0 Installation

### 3.1 Cabinet Mounting

The cabinet is designed to be wall mounted outside the robot work area in a relatively clean environment. Figure 1 shows the mounting dimensions of the electrical enclosure.

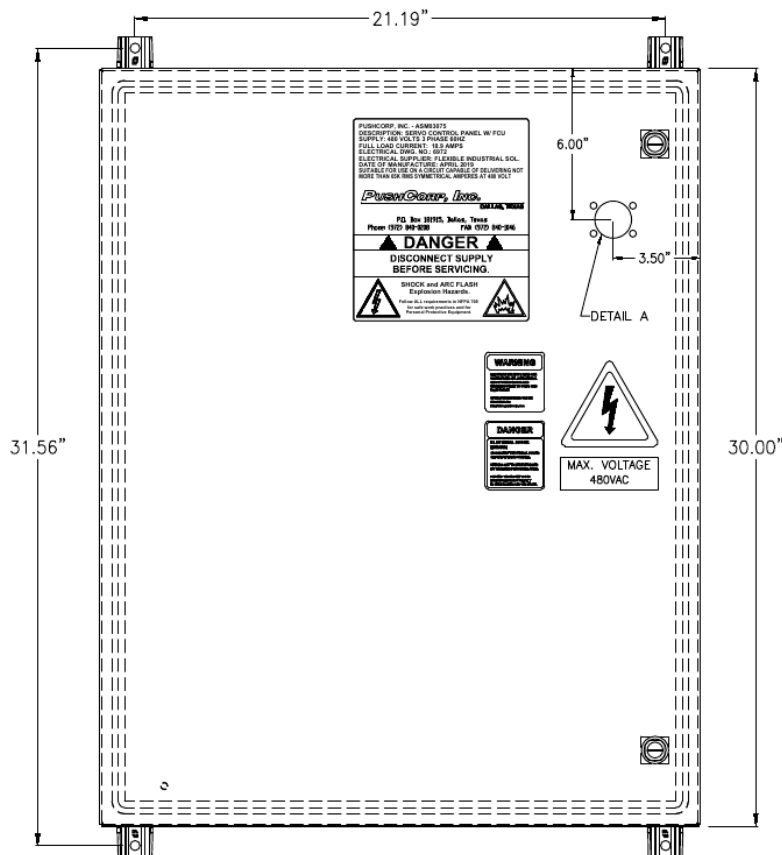

Figure 1. Cabinet Mounting

The overall measurements of the enclosure are 16" x 24" x 30" (DxWxH).

It is the responsibility of the installer to connect conduit, cord grips and/or cords as required for the electrical supply power wiring and low-voltage control signals.

### 3.2 Electrical Connections

The cabinet requires 480 VAC, 3-Phase, 50-60 Hz. power to operate. This should be supplied via conduit connection to the cabinet as shown in Figure 2 Top View. The control signal connections are made to the External Interface Blocks as shown in Figure 2 Bottom View and Figure 3 Safety Interface.

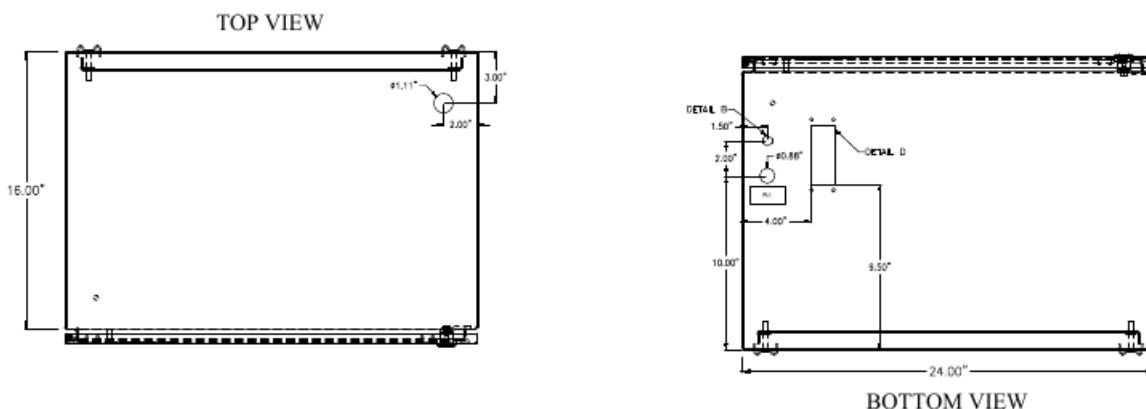

Figure 2. Panel entry locations

The circuit diagram in Figure 3 shows the safety connections required to make the control panel function. This connector is provided to allow safety rated connections to the SMFBCON5 panel.

**STO1-RETURN** is internally powered with 24V. **STO1-ENABLE** and **STO2-ENABLE** are configured to be either connected through a pair of dry contacts with **STO1-RETURN**. Or the **STO1-ENABLE** and **STO2-ENABLE** can be energized through an external 24V digital signal. These two connections shall satisfy the dual channel required in most robotic applications.

**SERVO SAFETY CONTACTOR 1 AND SERVO SAFETY CONTACTOR 2** will need to be connected to a 24V signal, preferably from a safety rated I/O point. This will in turn actuate the contactors and supply 480V to the servo amplifier on the panel.

**SERVO SAFETY CONTACTOR COMMON** will need to be connected to an external 0V.

Both **SERVO SAFETY CONTACTOR FEEDBACK** connections are connected to a normally closed contact. These contacts will open when the contactors are actuated, the STOs are enabled, and the RTO signal from the drive is on. The RTO signal indicates that the drive has power and there are no faults. The feedback signal is also connected to the internal IO module in the panel. If you choose to monitor these through the fieldbus connection, the signal designation can be found in section 4.3.1.

**It is the responsibility of the System Integrator and/or End-user to follow all applicable electrical codes and OSHA safety standards when wiring the control cabinet. This includes the proper and judicious use of ground termination, fuses, contactors, cut-off switches, lock-out switches, and Emergency Stop circuits. PushCorp, Inc. assumes no responsibility or liability for the electrical system**

design and implementation of the control cabinet in the End-user application. Refer to OSHA rules and regulations, as well as the CE Machinery Regulations (IEC 204-1), when designing systems that include motors and drives to ensure that the user is protected.

PushCorp will provide answers to any questions regarding the servo drive system and will be responsible for any warranty issues.

**NOTE: Please contact PushCorp, Inc. (Tel 1.972.840.0208) directly for any technical support.**

The SMFBCON5 panel is outfitted with a standard “Harting Style” connector. The 10 pin female connector which interfaces with SMFBCON5 panel is PN 09 33 010 2701 with a matching hood PN 09 30 010 1421. One of each of these is included with the panel from the factory.

Suitable cross references are:

TE – Insert - T2040102201-000 (HE-010-F) Hood - T1220100116-000 (H10B-TG-PG16)

Phoenix Contact – Insert – 1648186 Hood - 1412622

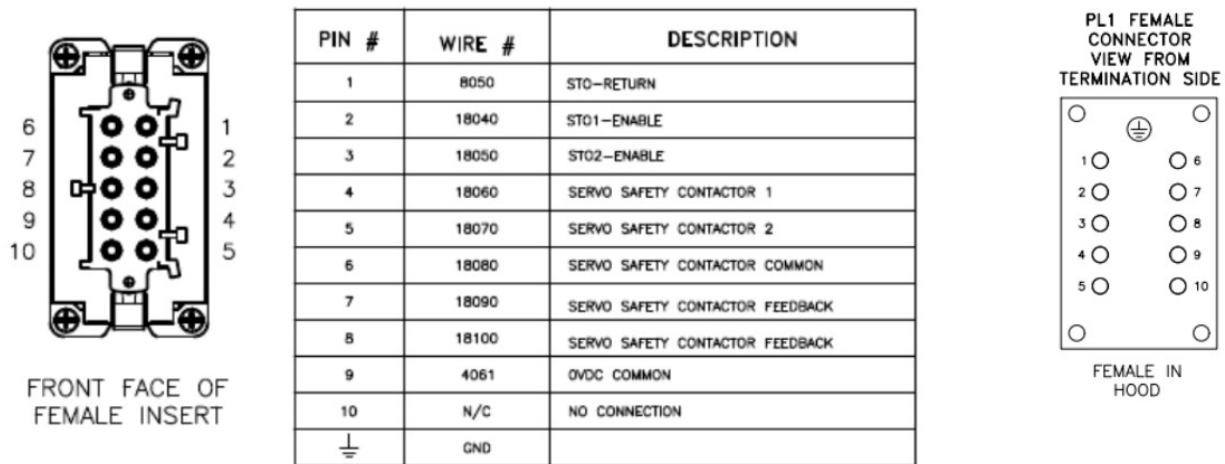

Figure 3. External Safety Interface Schematic

## 4.0 Programming Port

The SMFBCON5 panel comes with a programming port to allow access to the internal devices. This programming port is comprised of an RJ45, DB-9 RS-232 and a USB-B connections. The inter connection diagram for the programming may be seen in Figure 4. A computer can be connected to the RS-232 connection via a standard 9-pin male serial cable.

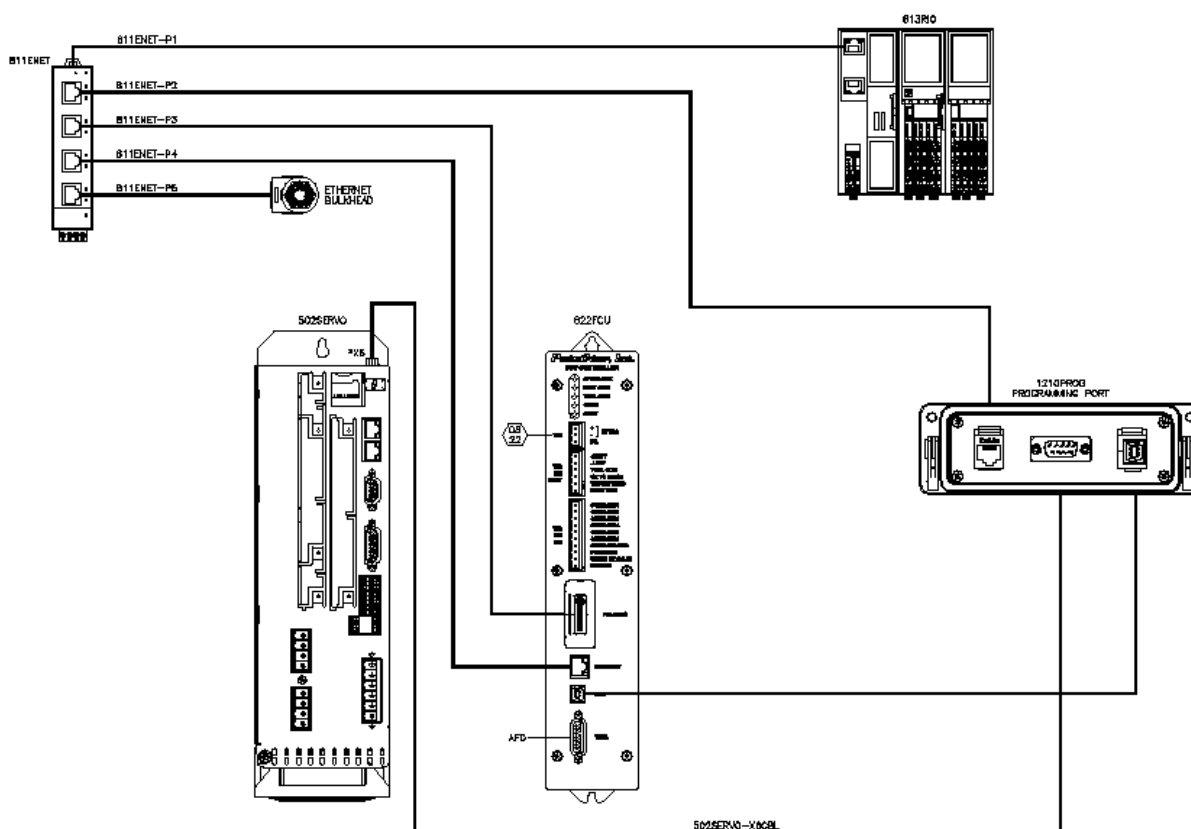

Figure 4. Programming Port Interface Schematic

## 5.0 IP Address Assignment

The PushCorp Control Panel has two devices which will have three IP addresses assigned to it, the Phoenix Contact Axio Coupler and the PushCorp FCUFLEX. These devices leave the factory with the following IP addresses assigned.

FCUFLEX – Programming Port – 192.168.1.12

FCUFLEX – Anybus I/O module – 192.168.1.11

Phoenix Contact – Axio Coupler – 192.168.1.10

Both the Phoenix Contact Axio Coupler and the PushCorp FCUFLEX Anybus module will be configured as “Generic Devices” with the following settings.



## 5.1 Changing IP Addresses

Each IP address will be managed either through web based interface or a dedicated software for the device. The links below will take you to landing pages to download the appropriate software.

### 5.1.1 Software-based Configuration

FCUFLEX – Anybus IO module -

<https://cloud.pushcorp.com/webdata/software/hms-IPConfigTool.zip>

FCUFLEX – Programming Port - AFD Dashboard -

<http://www.pushcorp.com/pages/software/afddashboard.msi>

### 5.1.2 Web-based Configuration

The Phoenix Contact Axio Coupler and the FCUFLEX Anybus Module can be configured through a web browser by simply putting the device's IP address in the address bar. This will bring up an interface where you can change the devices IP address and save the configuration.

For the Phoenix Contact unit you will need to enter the password "private" into the three password fields before the changes will take effect.

## 5.2 Ethernet IP EDS File Information

### 5.2.1 Axio Coupler Configuration

VendCode = 562;

ProdType = 12;

ProdCode = 8169;

MajRev = 1\*\*

MinRev = 2\*\*

Connection Instance: 0

Producing Connection: 110

Consuming Connection: 100

Input Scanner Size: 9 Words

Output Scanner Size: 9 Words

\*\*NOTE: If your connection requires the major and minor revision be input to the configuration and the above configuration did not work, use the last digit for each HW/FW on the side of the Phoenix Contact AXIO module. Example: HW/FW 00/111 Major Rev – 0 Min Rev – 1.

### 5.2.2 FCUFLEX Anybus Configuration

VendCode = 1444;

ProdType = 43;

ProdCode = 55;

MajRev = 1;

MinRev = 1;

Connection Instance: 1

Producing Connection: 100

Consuming Connection: 150

Input Scanner Size: 10 Words

Output Scanner Size: 5 Words

### 5.3 – Component I/O Mapping

#### 5.3.1 Axio Coupler I/O Map

The Axio Coupler will have three words of inputs and three words of outputs as viewed from the scanner.

#### 1503 / 0605 / 0612 Spindle IO Map

S724 Flex I/O Map

PxC IO Module Bit Map – 1503/0605/0612 Spindle

Inputs	DESCRIPTION	Outputs	DESCRIPTION
I 0001	Digital In – 1 – Contactor 1 On	O 0001	Digital Out – 1 – Servo Enable
I 0002	Digital In – 2 – Contactor 2 On	O 0002	Digital Out – 2 – Reset Fault
I 0003	Digital In – 3 – Drive Error Present	O 0003	Digital Out – 3 – Spare
I 0004	Digital In – 4 – RPM < 5	O 0004	Digital Out – 4 – Spare
I 0005	Digital In – 5 – Spare	O 0005	Digital Out – 5 – Spare
I 0006	Digital In – 6 – Spare	O 0006	Digital Out – 6 – Spare
I 0007	Digital In – 7 – Spare	O 0007	Digital Out – 7 – Spare
I 0008	Digital In – 8 – Spare	O 0008	Digital Out – 8 – Spare
I 0009	Reserved	O 0009	Reserved
I 0010	Reserved	O 0010	Reserved
I 0011	Reserved	O 0011	Reserved
I 0012	Reserved	O 0012	Reserved
I 0013	Reserved	O 0013	Reserved
I 0014	Reserved	O 0014	Reserved
I 0015	Reserved	O 0015	Reserved
I 0016	Reserved	O 0016	Reserved
I 0017	Analog In – 1 – Spindle Velocity/RPM	O 0017	Analog In – Reserved
I 0018	Analog In – 1 – Spindle Velocity/RPM	O 0018	Analog In – Reserved
I 0019	Analog In – 1 – Spindle Velocity/RPM	O 0019	Analog In – Reserved
I 0020	Analog In – 1 – Spindle Velocity/RPM	O 0020	Analog In – Reserved
I 0021	Analog In – 1 – Spindle Velocity/RPM	O 0021	Analog In – Reserved
I 0022	Analog In – 1 – Spindle Velocity/RPM	O 0022	Analog In – Reserved
I 0023	Analog In – 1 – Spindle Velocity/RPM	O 0023	Analog In – Reserved
I 0024	Analog In – 1 – Spindle Velocity/RPM	O 0024	Analog In – Reserved
I 0025	Analog In – 1 – Spindle Velocity/RPM	O 0025	Analog In – Reserved
I 0026	Analog In – 1 – Spindle Velocity/RPM	O 0026	Analog In – Reserved
I 0027	Analog In – 1 – Spindle Velocity/RPM	O 0027	Analog In – Reserved
I 0028	Analog In – 1 – Spindle Velocity/RPM	O 0028	Analog In – Reserved
I 0029	Analog In – 1 – Spindle Velocity/RPM	O 0029	Analog In – Reserved
I 0030	Analog In – 1 – Spindle Velocity/RPM	O 0030	Analog In – Reserved
I 0031	Analog In – 1 – Spindle Velocity/RPM	O 0031	Analog In – Reserved
I 0032	Analog In – 1 – Spindle Velocity/RPM	O 0032	Analog In – Reserved

Inputs	DESCRIPTION	Outputs	DESCRIPTION
I 0033	Analog In – 2 – Motor Load	O 0033	Analog In – Reserved
I 0034	Analog In – 2 – Motor Load	O 0034	Analog In – Reserved
I 0035	Analog In – 2 – Motor Load	O 0035	Analog In – Reserved
I 0036	Analog In – 2 – Motor Load	O 0036	Analog In – Reserved
I 0037	Analog In – 2 – Motor Load	O 0037	Analog In – Reserved
I 0038	Analog In – 2 – Motor Load	O 0038	Analog In – Reserved
I 0039	Analog In – 2 – Motor Load	O 0039	Analog In – Reserved
I 0040	Analog In – 2 – Motor Load	O 0040	Analog In – Reserved
I 0041	Analog In – 2 – Motor Load	O 0041	Analog In – Reserved
I 0042	Analog In – 2 – Motor Load	O 0042	Analog In – Reserved
I 0043	Analog In – 2 – Motor Load	O 0043	Analog In – Reserved
I 0044	Analog In – 2 – Motor Load	O 0044	Analog In – Reserved
I 0045	Analog In – 2 – Motor Load	O 0045	Analog In – Reserved
I 0046	Analog In – 2 – Motor Load	O 0046	Analog In – Reserved
I 0047	Analog In – 2 – Motor Load	O 0047	Analog In – Reserved
I 0048	Analog In – 2 – Motor Load	O 0048	Analog In – Reserved
I 0049	Analog In – 3 – Spare	O 0049	Analog In – Reserved
I 0050	Analog In – 3 – Spare	O 0050	Analog In – Reserved
I 0051	Analog In – 3 – Spare	O 0051	Analog In – Reserved
I 0052	Analog In – 3 – Spare	O 0052	Analog In – Reserved
I 0053	Analog In – 3 – Spare	O 0053	Analog In – Reserved
I 0054	Analog In – 3 – Spare	O 0054	Analog In – Reserved
I 0055	Analog In – 3 – Spare	O 0055	Analog In – Reserved
I 0056	Analog In – 3 – Spare	O 0056	Analog In – Reserved
I 0057	Analog In – 3 – Spare	O 0057	Analog In – Reserved
I 0058	Analog In – 3 – Spare	O 0058	Analog In – Reserved
I 0059	Analog In – 3 – Spare	O 0059	Analog In – Reserved
I 0060	Analog In – 3 – Spare	O 0060	Analog In – Reserved
I 0061	Analog In – 3 – Spare	O 0061	Analog In – Reserved
I 0062	Analog In – 3 – Spare	O 0062	Analog In – Reserved
I 0063	Analog In – 3 – Spare	O 0063	Analog In – Reserved
I 0064	Analog In – 3 – Spare	O 0064	Analog In – Reserved

Inputs	DESCRIPTION	Outputs	DESCRIPTION
I 0065	Analog In – 4 – Spare	O 0065	Analog In – Reserved
I 0066	Analog In – 4 – Spare	O 0066	Analog In – Reserved
I 0067	Analog In – 4 – Spare	O 0067	Analog In – Reserved
I 0068	Analog In – 4 – Spare	O 0068	Analog In – Reserved
I 0069	Analog In – 4 – Spare	O 0069	Analog In – Reserved
I 0070	Analog In – 4 – Spare	O 0070	Analog In – Reserved
I 0071	Analog In – 4 – Spare	O 0071	Analog In – Reserved
I 0072	Analog In – 4 – Spare	O 0072	Analog In – Reserved
I 0073	Analog In – 4 – Spare	O 0073	Analog In – Reserved
I 0074	Analog In – 4 – Spare	O 0074	Analog In – Reserved
I 0075	Analog In – 4 – Spare	O 0075	Analog In – Reserved
I 0076	Analog In – 4 – Spare	O 0076	Analog In – Reserved
I 0077	Analog In – 4 – Spare	O 0077	Analog In – Reserved
I 0078	Analog In – 4 – Spare	O 0078	Analog In – Reserved
I 0079	Analog In – 4 – Spare	O 0079	Analog In – Reserved
I 0080	Analog In – 4 – Spare	O 0080	Analog In – Reserved
I 0081	Analog In – Reserved	O 0081	Analog Out – 1 – Spindle Speed
I 0082	Analog In – Reserved	O 0082	Analog Out – 1 – Spindle Speed
I 0083	Analog In – Reserved	O 0083	Analog Out – 1 – Spindle Speed
I 0084	Analog In – Reserved	O 0084	Analog Out – 1 – Spindle Speed
I 0085	Analog In – Reserved	O 0085	Analog Out – 1 – Spindle Speed
I 0086	Analog In – Reserved	O 0086	Analog Out – 1 – Spindle Speed
I 0087	Analog In – Reserved	O 0087	Analog Out – 1 – Spindle Speed
I 0088	Analog In – Reserved	O 0088	Analog Out – 1 – Spindle Speed
I 0089	Analog In – Reserved	O 0089	Analog Out – 1 – Spindle Speed
I 0090	Analog In – Reserved	O 0090	Analog Out – 1 – Spindle Speed
I 0091	Analog In – Reserved	O 0091	Analog Out – 1 – Spindle Speed
I 0092	Analog In – Reserved	O 0092	Analog Out – 1 – Spindle Speed
I 0093	Analog In – Reserved	O 0093	Analog Out – 1 – Spindle Speed
I 0094	Analog In – Reserved	O 0094	Analog Out – 1 – Spindle Speed
I 0095	Analog In – Reserved	O 0095	Analog Out – 1 – Spindle Speed
I 0096	Analog In – Reserved	O 0096	Analog Out – 1 – Spindle Speed

Inputs	DESCRIPTION	Outputs	DESCRIPTION
I 0097	Analog In – Reserved	O 0097	Analog Out – 2 – Spare
I 0098	Analog In – Reserved	O 0098	Analog Out – 2 – Spare
I 0099	Analog In – Reserved	O 0099	Analog Out – 2 – Spare
I 0100	Analog In – Reserved	O 0100	Analog Out – 2 – Spare
I 0101	Analog In – Reserved	O 0101	Analog Out – 2 – Spare
I 0102	Analog In – Reserved	O 0102	Analog Out – 2 – Spare
I 0103	Analog In – Reserved	O 0103	Analog Out – 2 – Spare
I 0104	Analog In – Reserved	O 0104	Analog Out – 2 – Spare
I 0105	Analog In – Reserved	O 0105	Analog Out – 2 – Spare
I 0106	Analog In – Reserved	O 0106	Analog Out – 2 – Spare
I 0107	Analog In – Reserved	O 0107	Analog Out – 2 – Spare
I 0108	Analog In – Reserved	O 0108	Analog Out – 2 – Spare
I 0109	Analog In – Reserved	O 0109	Analog Out – 2 – Spare
I 0110	Analog In – Reserved	O 0110	Analog Out – 2 – Spare
I 0111	Analog In – Reserved	O 0111	Analog Out – 2 – Spare
I 0112	Analog In – Reserved	O 0112	Analog Out – 2 – Spare
I 0113	Analog In – Reserved	O 0113	Analog Out – 3 – Spare
I 0114	Analog In – Reserved	O 0114	Analog Out – 3 – Spare
I 0115	Analog In – Reserved	O 0115	Analog Out – 3 – Spare
I 0116	Analog In – Reserved	O 0116	Analog Out – 3 – Spare
I 0117	Analog In – Reserved	O 0117	Analog Out – 3 – Spare
I 0118	Analog In – Reserved	O 0118	Analog Out – 3 – Spare
I 0119	Analog In – Reserved	O 0119	Analog Out – 3 – Spare
I 0120	Analog In – Reserved	O 0120	Analog Out – 3 – Spare
I 0121	Analog In – Reserved	O 0121	Analog Out – 3 – Spare
I 0122	Analog In – Reserved	O 0122	Analog Out – 3 – Spare
I 0123	Analog In – Reserved	O 0123	Analog Out – 3 – Spare
I 0124	Analog In – Reserved	O 0124	Analog Out – 3 – Spare
I 0125	Analog In – Reserved	O 0125	Analog Out – 3 – Spare
I 0126	Analog In – Reserved	O 0126	Analog Out – 3 – Spare
I 0127	Analog In – Reserved	O 0127	Analog Out – 3 – Spare
I 0128	Analog In – Reserved	O 0128	Analog Out – 3 – Spare

Inputs	DESCRIPTION	Outputs	DESCRIPTION
I 0129	Analog In – Reserved	O 0129	Analog Out – 4 – Spare
I 0130	Analog In – Reserved	O 0130	Analog Out – 4 – Spare
I 0131	Analog In – Reserved	O 0131	Analog Out – 4 – Spare
I 0132	Analog In – Reserved	O 0132	Analog Out – 4 – Spare
I 0133	Analog In – Reserved	O 0133	Analog Out – 4 – Spare
I 0134	Analog In – Reserved	O 0134	Analog Out – 4 – Spare
I 0135	Analog In – Reserved	O 0135	Analog Out – 4 – Spare
I 0136	Analog In – Reserved	O 0136	Analog Out – 4 – Spare
I 0137	Analog In – Reserved	O 0137	Analog Out – 4 – Spare
I 0138	Analog In – Reserved	O 0138	Analog Out – 4 – Spare
I 0139	Analog In – Reserved	O 0139	Analog Out – 4 – Spare
I 0140	Analog In – Reserved	O 0140	Analog Out – 4 – Spare
I 0141	Analog In – Reserved	O 0141	Analog Out – 4 – Spare
I 0142	Analog In – Reserved	O 0142	Analog Out – 4 – Spare
I 0143	Analog In – Reserved	O 0143	Analog Out – 4 – Spare
I 0144	Analog In – Reserved	O 0144	Analog Out – 4 – Spare

### 1015 / 1515 Spindle IO Map

S724 Flex I/O Map

PxC IO Module Bit Map – 1015/1515 Spindle

Inputs	DESCRIPTION	Outputs	DESCRIPTION
I 0001	Digital In – 1 – Contactor 1 On	O 0001	Digital Out – 1 – Servo Enable
I 0002	Digital In – 2 – Contactor 2 On	O 0002	Digital Out – 2 – Spindle On
I 0003	Digital In – 3 – At Tool Change Position	O 0003	Digital Out – 3 – Reset Fault
I 0004	Digital In – 4 – RPM < 5	O 0004	Digital Out – 4 – Move to TC Position
I 0005	Digital In – 5 – Spare	O 0005	Digital Out – 5 – Spare
I 0006	Digital In – 6 – Spare	O 0006	Digital Out – 6 – Spare
I 0007	Digital In – 7 – Spare	O 0007	Digital Out – 7 – Spare
I 0008	Digital In – 8 – Spare	O 0008	Digital Out – 8 – Spare
I 0009	Reserved	O 0009	Reserved
I 0010	Reserved	O 0010	Reserved
I 0011	Reserved	O 0011	Reserved
I 0012	Reserved	O 0012	Reserved
I 0013	Reserved	O 0013	Reserved
I 0014	Reserved	O 0014	Reserved
I 0015	Reserved	O 0015	Reserved
I 0016	Reserved	O 0016	Reserved
I 0017	Analog In – 1 – Spindle Velocity/RPM	O 0017	Analog In – Reserved
I 0018	Analog In – 1 – Spindle Velocity/RPM	O 0018	Analog In – Reserved
I 0019	Analog In – 1 – Spindle Velocity/RPM	O 0019	Analog In – Reserved
I 0020	Analog In – 1 – Spindle Velocity/RPM	O 0020	Analog In – Reserved
I 0021	Analog In – 1 – Spindle Velocity/RPM	O 0021	Analog In – Reserved
I 0022	Analog In – 1 – Spindle Velocity/RPM	O 0022	Analog In – Reserved
I 0023	Analog In – 1 – Spindle Velocity/RPM	O 0023	Analog In – Reserved
I 0024	Analog In – 1 – Spindle Velocity/RPM	O 0024	Analog In – Reserved
I 0025	Analog In – 1 – Spindle Velocity/RPM	O 0025	Analog In – Reserved
I 0026	Analog In – 1 – Spindle Velocity/RPM	O 0026	Analog In – Reserved
I 0027	Analog In – 1 – Spindle Velocity/RPM	O 0027	Analog In – Reserved
I 0028	Analog In – 1 – Spindle Velocity/RPM	O 0028	Analog In – Reserved
I 0029	Analog In – 1 – Spindle Velocity/RPM	O 0029	Analog In – Reserved
I 0030	Analog In – 1 – Spindle Velocity/RPM	O 0030	Analog In – Reserved
I 0031	Analog In – 1 – Spindle Velocity/RPM	O 0031	Analog In – Reserved
I 0032	Analog In – 1 – Spindle Velocity/RPM	O 0032	Analog In – Reserved

Inputs	DESCRIPTION	Outputs	DESCRIPTION
I 0033	Analog In – 2 – Motor Load	O 0033	Analog In – Reserved
I 0034	Analog In – 2 – Motor Load	O 0034	Analog In – Reserved
I 0035	Analog In – 2 – Motor Load	O 0035	Analog In – Reserved
I 0036	Analog In – 2 – Motor Load	O 0036	Analog In – Reserved
I 0037	Analog In – 2 – Motor Load	O 0037	Analog In – Reserved
I 0038	Analog In – 2 – Motor Load	O 0038	Analog In – Reserved
I 0039	Analog In – 2 – Motor Load	O 0039	Analog In – Reserved
I 0040	Analog In – 2 – Motor Load	O 0040	Analog In – Reserved
I 0041	Analog In – 2 – Motor Load	O 0041	Analog In – Reserved
I 0042	Analog In – 2 – Motor Load	O 0042	Analog In – Reserved
I 0043	Analog In – 2 – Motor Load	O 0043	Analog In – Reserved
I 0044	Analog In – 2 – Motor Load	O 0044	Analog In – Reserved
I 0045	Analog In – 2 – Motor Load	O 0045	Analog In – Reserved
I 0046	Analog In – 2 – Motor Load	O 0046	Analog In – Reserved
I 0047	Analog In – 2 – Motor Load	O 0047	Analog In – Reserved
I 0048	Analog In – 2 – Motor Load	O 0048	Analog In – Reserved
I 0049	Analog In – 3 – Spare	O 0049	Analog In – Reserved
I 0050	Analog In – 3 – Spare	O 0050	Analog In – Reserved
I 0051	Analog In – 3 – Spare	O 0051	Analog In – Reserved
I 0052	Analog In – 3 – Spare	O 0052	Analog In – Reserved
I 0053	Analog In – 3 – Spare	O 0053	Analog In – Reserved
I 0054	Analog In – 3 – Spare	O 0054	Analog In – Reserved
I 0055	Analog In – 3 – Spare	O 0055	Analog In – Reserved
I 0056	Analog In – 3 – Spare	O 0056	Analog In – Reserved
I 0057	Analog In – 3 – Spare	O 0057	Analog In – Reserved
I 0058	Analog In – 3 – Spare	O 0058	Analog In – Reserved
I 0059	Analog In – 3 – Spare	O 0059	Analog In – Reserved
I 0060	Analog In – 3 – Spare	O 0060	Analog In – Reserved
I 0061	Analog In – 3 – Spare	O 0061	Analog In – Reserved
I 0062	Analog In – 3 – Spare	O 0062	Analog In – Reserved
I 0063	Analog In – 3 – Spare	O 0063	Analog In – Reserved
I 0064	Analog In – 3 – Spare	O 0064	Analog In – Reserved

Inputs	DESCRIPTION
I 0065	Analog In - 4 - Spare
I 0066	Analog In - 4 - Spare
I 0067	Analog In - 4 - Spare
I 0068	Analog In - 4 - Spare
I 0069	Analog In - 4 - Spare
I 0070	Analog In - 4 - Spare
I 0071	Analog In - 4 - Spare
I 0072	Analog In - 4 - Spare
I 0073	Analog In - 4 - Spare
I 0074	Analog In - 4 - Spare
I 0075	Analog In - 4 - Spare
I 0076	Analog In - 4 - Spare
I 0077	Analog In - 4 - Spare
I 0078	Analog In - 4 - Spare
I 0079	Analog In - 4 - Spare
I 0080	Analog In - 4 - Spare
I 0081	Analog In - Reserved
I 0082	Analog In - Reserved
I 0083	Analog In - Reserved
I 0084	Analog In - Reserved
I 0085	Analog In - Reserved
I 0086	Analog In - Reserved
I 0087	Analog In - Reserved
I 0088	Analog In - Reserved
I 0089	Analog In - Reserved
I 0090	Analog In - Reserved
I 0091	Analog In - Reserved
I 0092	Analog In - Reserved
I 0093	Analog In - Reserved
I 0094	Analog In - Reserved
I 0095	Analog In - Reserved
I 0096	Analog In - Reserved

Outputs	DESCRIPTION
O 0065	Analog In - Reserved
O 0066	Analog In - Reserved
O 0067	Analog In - Reserved
O 0068	Analog In - Reserved
O 0069	Analog In - Reserved
O 0070	Analog In - Reserved
O 0071	Analog In - Reserved
O 0072	Analog In - Reserved
O 0073	Analog In - Reserved
O 0074	Analog In - Reserved
O 0075	Analog In - Reserved
O 0076	Analog In - Reserved
O 0077	Analog In - Reserved
O 0078	Analog In - Reserved
O 0079	Analog In - Reserved
O 0080	Analog In - Reserved
O 0081	Analog Out - 1 - Spindle Speed
O 0082	Analog Out - 1 - Spindle Speed
O 0083	Analog Out - 1 - Spindle Speed
O 0084	Analog Out - 1 - Spindle Speed
O 0085	Analog Out - 1 - Spindle Speed
O 0086	Analog Out - 1 - Spindle Speed
O 0087	Analog Out - 1 - Spindle Speed
O 0088	Analog Out - 1 - Spindle Speed
O 0089	Analog Out - 1 - Spindle Speed
O 0090	Analog Out - 1 - Spindle Speed
O 0091	Analog Out - 1 - Spindle Speed
O 0092	Analog Out - 1 - Spindle Speed
O 0093	Analog Out - 1 - Spindle Speed
O 0094	Analog Out - 1 - Spindle Speed
O 0095	Analog Out - 1 - Spindle Speed
O 0096	Analog Out - 1 - Spindle Speed

Inputs	DESCRIPTION
I 0097	Analog In - Reserved
I 0098	Analog In - Reserved
I 0099	Analog In - Reserved
I 0100	Analog In - Reserved
I 0101	Analog In - Reserved
I 0102	Analog In - Reserved
I 0103	Analog In - Reserved
I 0104	Analog In - Reserved
I 0105	Analog In - Reserved
I 0106	Analog In - Reserved
I 0107	Analog In - Reserved
I 0108	Analog In - Reserved
I 0109	Analog In - Reserved
I 0110	Analog In - Reserved
I 0111	Analog In - Reserved
I 0112	Analog In - Reserved
I 0113	Analog In - Reserved
I 0114	Analog In - Reserved
I 0115	Analog In - Reserved
I 0116	Analog In - Reserved
I 0117	Analog In - Reserved
I 0118	Analog In - Reserved
I 0119	Analog In - Reserved
I 0120	Analog In - Reserved
I 0121	Analog In - Reserved
I 0122	Analog In - Reserved
I 0123	Analog In - Reserved
I 0124	Analog In - Reserved
I 0125	Analog In - Reserved
I 0126	Analog In - Reserved
I 0127	Analog In - Reserved
I 0128	Analog In - Reserved

Outputs	DESCRIPTION
O 0097	Analog Out - 2 - Spare
O 0098	Analog Out - 2 - Spare
O 0099	Analog Out - 2 - Spare
O 0100	Analog Out - 2 - Spare
O 0101	Analog Out - 2 - Spare
O 0102	Analog Out - 2 - Spare
O 0103	Analog Out - 2 - Spare
O 0104	Analog Out - 2 - Spare
O 0105	Analog Out - 2 - Spare
O 0106	Analog Out - 2 - Spare
O 0107	Analog Out - 2 - Spare
O 0108	Analog Out - 2 - Spare
O 0109	Analog Out - 2 - Spare
O 0110	Analog Out - 2 - Spare
O 0111	Analog Out - 2 - Spare
O 0112	Analog Out - 2 - Spare
O 0113	Analog Out - 3 - Spare
O 0114	Analog Out - 3 - Spare
O 0115	Analog Out - 3 - Spare
O 0116	Analog Out - 3 - Spare
O 0117	Analog Out - 3 - Spare
O 0118	Analog Out - 3 - Spare
O 0119	Analog Out - 3 - Spare
O 0120	Analog Out - 3 - Spare
O 0121	Analog Out - 3 - Spare
O 0122	Analog Out - 3 - Spare
O 0123	Analog Out - 3 - Spare
O 0124	Analog Out - 3 - Spare
O 0125	Analog Out - 3 - Spare
O 0126	Analog Out - 3 - Spare
O 0127	Analog Out - 3 - Spare
O 0128	Analog Out - 3 - Spare

Inputs	DESCRIPTION	Outputs	DESCRIPTION
I 0129	Analog In – Reserved	O 0129	Analog Out – 4 – Spare
I 0130	Analog In – Reserved	O 0130	Analog Out – 4 – Spare
I 0131	Analog In – Reserved	O 0131	Analog Out – 4 – Spare
I 0132	Analog In – Reserved	O 0132	Analog Out – 4 – Spare
I 0133	Analog In – Reserved	O 0133	Analog Out – 4 – Spare
I 0134	Analog In – Reserved	O 0134	Analog Out – 4 – Spare
I 0135	Analog In – Reserved	O 0135	Analog Out – 4 – Spare
I 0136	Analog In – Reserved	O 0136	Analog Out – 4 – Spare
I 0137	Analog In – Reserved	O 0137	Analog Out – 4 – Spare
I 0138	Analog In – Reserved	O 0138	Analog Out – 4 – Spare
I 0139	Analog In – Reserved	O 0139	Analog Out – 4 – Spare
I 0140	Analog In – Reserved	O 0140	Analog Out – 4 – Spare
I 0141	Analog In – Reserved	O 0141	Analog Out – 4 – Spare
I 0142	Analog In – Reserved	O 0142	Analog Out – 4 – Spare
I 0143	Analog In – Reserved	O 0143	Analog Out – 4 – Spare
I 0144	Analog In – Reserved	O 0144	Analog Out – 4 – Spare

The analog cards are scaled where a 10V input/output is 30,000 bits and -10V input/output is -30,000 bits. This information is required when configuring the device that will command the speed of the spindle. 10 volts will scale to 30,000 bits.

Typically the formula for converting these bits to an actual RPM is:  
 Command Bits = ((Desired RPM)\*(30000))/(Max RPM of Spindle)

**5.3.1 FCUFLEX I/O Map**

The FCUFLEX will have ten words of inputs and five words of outputs as viewed from the scanner.

S724 Flex I/O Map

FCU Flex IO

Inputs	DESCRIPTION	Scaling	Outputs	DESCRIPTION	Scaling
I 0001	CPU Heartbeat	None	O 0001	Set Command Force	X10
I 0002	Host Comm		O 0002	Set Command Force	
I 0003	Tool Comm		O 0003	Set Command Force	
I 0004	Metric Unit		O 0004	Set Command Force	
I 0005	Pos Limit		O 0005	Set Command Force	
I 0006	Neg Limit		O 0006	Set Command Force	
I 0007	At Weigh Position		O 0007	Set Command Force	
I 0008	Weighing in Progress		O 0008	Set Command Force	
I 0009	Weight Valid		O 0009	Set Command Force	
I 0010	Spare		O 0010	Set Command Force	
I 0011	Spare		O 0011	Set Command Force	
I 0012	Spare		O 0012	Set Command Force	
I 0013	Spare		O 0013	Set Command Force	
I 0014	Spare		O 0014	Set Command Force	
I 0015	Spare		O 0015	Set Command Force	
I 0016	Spare		O 0016	Set Command Force	
I 0017	Actual Force	X10	O 0017	Set Command Position	X100
I 0018	Actual Force		O 0018	Set Command Position	
I 0019	Actual Force		O 0019	Set Command Position	
I 0020	Actual Force		O 0020	Set Command Position	
I 0021	Actual Force		O 0021	Set Command Position	
I 0022	Actual Force		O 0022	Set Command Position	
I 0023	Actual Force		O 0023	Set Command Position	
I 0024	Actual Force		O 0024	Set Command Position	
I 0025	Actual Force		O 0025	Set Command Position	
I 0026	Actual Force		O 0026	Set Command Position	
I 0027	Actual Force		O 0027	Set Command Position	
I 0028	Actual Force		O 0028	Set Command Position	
I 0029	Actual Force		O 0029	Set Command Position	
I 0030	Actual Force		O 0030	Set Command Position	
I 0031	Actual Force		O 0031	Set Command Position	
I 0032	Actual Force		O 0032	Set Command Position	

Inputs	DESCRIPTION	Scaling	Outputs	DESCRIPTION	Scaling
I 0033	Actual Position	X100	O 0033	Set Payload Weight	X10
I 0034	Actual Position		O 0034	Set Payload Weight	
I 0035	Actual Position		O 0035	Set Payload Weight	
I 0036	Actual Position		O 0036	Set Payload Weight	
I 0037	Actual Position		O 0037	Set Payload Weight	
I 0038	Actual Position		O 0038	Set Payload Weight	
I 0039	Actual Position		O 0039	Set Payload Weight	
I 0040	Actual Position		O 0040	Set Payload Weight	
I 0041	Actual Position		O 0041	Set Payload Weight	
I 0042	Actual Position		O 0042	Set Payload Weight	
I 0043	Actual Position		O 0043	Set Payload Weight	
I 0044	Actual Position		O 0044	Set Payload Weight	
I 0045	Actual Position		O 0045	Set Payload Weight	
I 0046	Actual Position		O 0046	Set Payload Weight	
I 0047	Actual Position		O 0047	Set Payload Weight	
I 0048	Actual Position		O 0048	Set Payload Weight	
I 0049	Accel Gravity	X1000	O 0049	Set Control Mode	None
I 0050	Accel Gravity		O 0050	Set Control Mode	
I 0051	Accel Gravity		O 0051	Set Control Mode	
I 0052	Accel Gravity		O 0052	Set Control Mode	
I 0053	Accel Gravity		O 0053	Set Control Mode	
I 0054	Accel Gravity		O 0054	Set Control Mode	
I 0055	Accel Gravity		O 0055	Set Control Mode	
I 0056	Accel Gravity		O 0056	Set Control Mode	
I 0057	Accel Gravity		O 0057	Set Control Mode	
I 0058	Accel Gravity		O 0058	Set Control Mode	
I 0059	Accel Gravity		O 0059	Set Control Mode	
I 0060	Accel Gravity		O 0060	Set Control Mode	
I 0061	Accel Gravity		O 0061	Set Control Mode	
I 0062	Accel Gravity		O 0062	Set Control Mode	
I 0063	Accel Gravity		O 0063	Set Control Mode	
I 0064	Accel Gravity		O 0064	Set Control Mode	



Inputs	DESCRIPTION	Scaling	Outputs	DESCRIPTION	Scaling
I 0065	Command Force	X10	O 0065	Weigh Payload	None
I 0066	Command Force		O 0066	Weigh Payload	
I 0067	Command Force		O 0067	Weigh Payload	
I 0068	Command Force		O 0068	Weigh Payload	
I 0069	Command Force		O 0069	Weigh Payload	
I 0070	Command Force		O 0070	Weigh Payload	
I 0071	Command Force		O 0071	Weigh Payload	
I 0072	Command Force		O 0072	Weigh Payload	
I 0073	Command Force		O 0073	Weigh Payload	
I 0074	Command Force		O 0074	Weigh Payload	
I 0075	Command Force		O 0075	Weigh Payload	
I 0076	Command Force		O 0076	Weigh Payload	
I 0077	Command Force		O 0077	Weigh Payload	
I 0078	Command Force		O 0078	Weigh Payload	
I 0079	Command Force		O 0079	Weigh Payload	
I 0080	Command Force	O 0080	Weigh Payload		
I 0081	Command Position	X100	O 0081		
I 0082	Command Position		O 0082		
I 0083	Command Position		O 0083		
I 0084	Command Position		O 0084		
I 0085	Command Position		O 0085		
I 0086	Command Position		O 0086		
I 0087	Command Position		O 0087		
I 0088	Command Position		O 0088		
I 0089	Command Position		O 0089		
I 0090	Command Position		O 0090		
I 0091	Command Position		O 0091		
I 0092	Command Position		O 0092		
I 0093	Command Position		O 0093		
I 0094	Command Position		O 0094		
I 0095	Command Position		O 0095		
I 0096	Command Position		O 0096		

Inputs	DESCRIPTION	Scaling	Outputs	DESCRIPTION	Scaling
I 0097	Payload Weight	X10	O 0097		
I 0098	Payload Weight		O 0098		
I 0099	Payload Weight		O 0099		
I 0100	Payload Weight		O 0100		
I 0101	Payload Weight		O 0101		
I 0102	Payload Weight		O 0102		
I 0103	Payload Weight		O 0103		
I 0104	Payload Weight		O 0104		
I 0105	Payload Weight		O 0105		
I 0106	Payload Weight		O 0106		
I 0107	Payload Weight		O 0107		
I 0108	Payload Weight		O 0108		
I 0109	Payload Weight		O 0109		
I 0110	Payload Weight		O 0110		
I 0111	Payload Weight		O 0111		
I 0112	Payload Weight	O 0112			
I 0113	Control Mode	None	O 0113		
I 0114	Control Mode		O 0114		
I 0115	Control Mode		O 0115		
I 0116	Control Mode		O 0116		
I 0117	Control Mode		O 0117		
I 0118	Control Mode		O 0118		
I 0119	Control Mode		O 0119		
I 0120	Control Mode		O 0120		
I 0121	Control Mode		O 0121		
I 0122	Control Mode		O 0122		
I 0123	Control Mode		O 0123		
I 0124	Control Mode		O 0124		
I 0125	Control Mode		O 0125		
I 0126	Control Mode		O 0126		
I 0127	Control Mode		O 0127		
I 0128	Control Mode		O 0128		

Inputs	DESCRIPTION	Scaling	Outputs	DESCRIPTION	Scaling
I 0129	Max Force	X10	O 0129		
I 0130	Max Force		O 0130		
I 0131	Max Force		O 0131		
I 0132	Max Force		O 0132		
I 0133	Max Force		O 0133		
I 0134	Max Force		O 0134		
I 0135	Max Force		O 0135		
I 0136	Max Force		O 0136		
I 0137	Max Force		O 0137		
I 0138	Max Force		O 0138		
I 0139	Max Force		O 0139		
I 0140	Max Force		O 0140		
I 0141	Max Force		O 0141		
I 0142	Max Force		O 0142		
I 0143	Max Force	O 0143			
I 0144	Max Force	O 0144			
I 0145	Max Position	X100	O 0145		
I 0146	Max Position		O 0146		
I 0147	Max Position		O 0147		
I 0148	Max Position		O 0148		
I 0149	Max Position		O 0149		
I 0150	Max Position		O 0150		
I 0151	Max Position		O 0151		
I 0152	Max Position		O 0152		
I 0153	Max Position		O 0153		
I 0154	Max Position		O 0154		
I 0155	Max Position		O 0155		
I 0156	Max Position		O 0156		
I 0157	Max Position	O 0157			
I 0158	Max Position	O 0158			
I 0159	Max Position	O 0159			
I 0160	Max Position	O 0160			

## **6.0 Technical Specifications and Schematics**

Supply Voltage: 480 VAC, 3-Phase  
Max. Cont. Current: 30 Amps  
Max. Peak Current: 60 Amps (2 Seconds)  
Dimensions: 16" x 24" x 30" (DxWxH)  
Weight: 250 lbs

*Specifications subject to change without notice.*

## 7.0 Spare Replacement Parts

Part	Description	P/N
Analog Module for SMFBCON	Analog Module for SMFBCON	PAR05488
LPJ-30SP Class J Fuse	LPJ-30SP Class J Fuse	PAR05491
LPCC-4 Class CC Fuse	LPCC-4 Class CC Fuse	PAR05492
8IN Exhaust Filter Fan	8IN Exhaust Filter Fan	PAR05493
3-Phase 24 VDC Power Supply	3 Phase Power Supply, Input Voltage: 3X400 to 500VaC or 260 to 300 VdC; Freq Range: 50-60 Hz; Output Voltage: 24 VdC; Current: 10 Amps	PAR05494
24 VDC Circuit Breaker	Electronic circuit breaker; Rated voltage: 24VdC; Rated Current: 4A; Feedback Resistance: max 35 VdC	PAR05495
5 RJ45 Port Industrial Ethernet Switch	Industrial Ethernet Switch; No. of Channels: 5 RJ45 Ports; Transmission Speed: 10/100 Mbps; Supply Voltage: 24 VdC; Typical Current Consumption: 90 mA	PAR05496
Bus Coupler	Bus Coupler	PAR05497
8 Input 24 VdC Digital Module	8 Input 24 VdC Digital Module	PAR05498
4 Input Analog Input Module	Analog input module; 4 Inputs: (0-5V), (-5-5V), (0-10V), (-10-10V); Limit Freq: 30 Hz, Transmission Speed: 100 Mbps	PAR05499
4 Ouput Analog Output Module	4 Output Analog Output Module	PAR05500
3-Pole 24 VdC Power Contactor	3-Pole 24 VDC Power Contactor	PAR05501
10-Pole HDC Heavy Duty Connector	10-Pole HDC Heavy Duty Connector	PAR05502