

SECTION A-A

CUSTOMER DRAWING

This drawing is the property of Rev-A-Shelf (RAS) and is disclosed in confidence to the extent its subject matter is original to RAS. Any vendor receiving this drawing from RAS shall hold and use this drawing for the sole benefit of RAS and shall not disclose it to, or use or reproduce it for any third party, or perform any act adverse to the interest of RAS with respect to this drawing without the express written permission of RAS. Vendors shall not revise any physical, dimensional or performance characteristic unless authorized by Rev-A-Shelf Engineering.

REV.	DATE	BY	DESCRIPTION OF CHANGE

INCH [MM]	AMERICAN PROJECTION 	BY	DATE	REV-A-SHELF, INC.	
		DRAWN	KRR	8-1-22	SIZE B
TOLERANCES		MATERIAL	DRAWING NO.		SCALE
MAT.	DEC.		448-BSKS-3C		0.200
(WOOD)	.XX ±.03 [8mm]	FINISH	PART NO.		SHEET OF
(OTHER)	.XX ±.02 [5mm]		448-BSKS-3C		
(ALL)	.XXX ±.005 [13 mm]				
FRACTIONS	±1/32 [8 mm]				

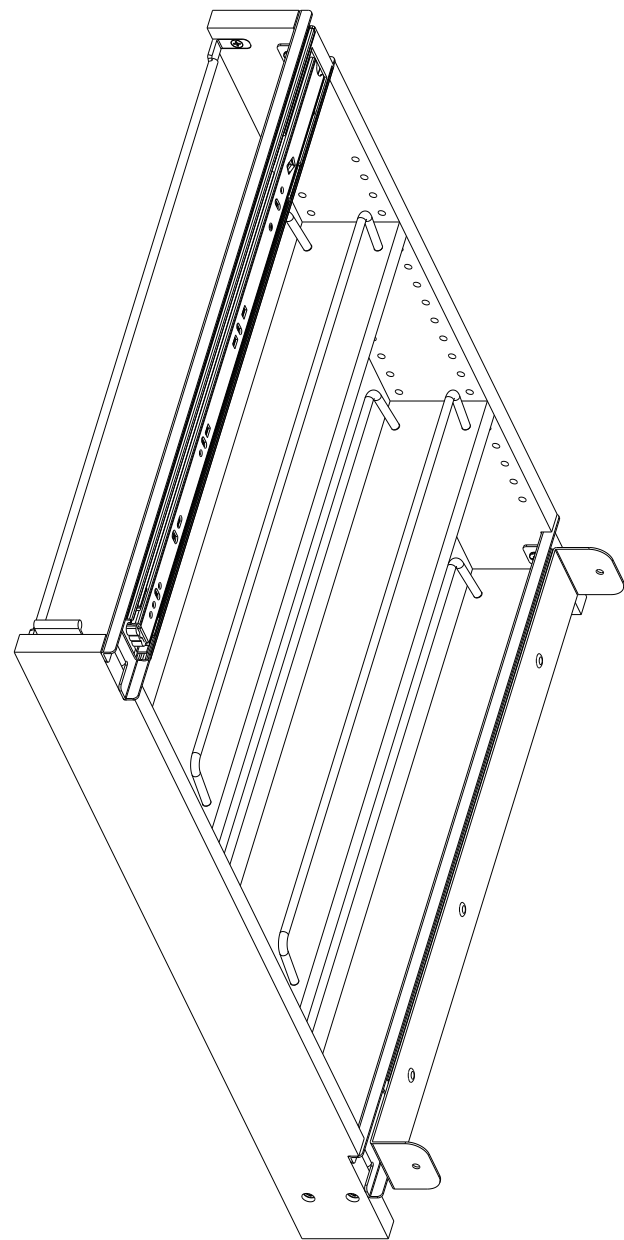

PART DIMENSIONS		
	MIN	MAX
WIDTH	3.00	4.50
DEPTH	21.34	
HEIGHT	24.57	24.94
CONTAINER CAPACITY		
CONTAINER UOM		

SLIDE SPECIFICATIONS				
SLIDE MANUFACTURER				
SLIDE PART NUMBER		RELEASE PART NUMBER		
SLIDE TYPE	BALL BEARING	SLIDE EXTENSION	FULL	MAX WEIGHT RATING
SLIDE CLOSING	NORMAL	SLIDE LENGTH	17.72 [450MM]	
SLIDE MOUNTING	SIDE	SLIDE FINISH	ZINC	75 LB

CUSTOMER DRAWING

This drawing is the property of Rev-A-Shelf (RAS) and is disclosed in confidence to the extent its subject matter is original to RAS. Any vendor receiving this drawing from RAS shall hold and use this drawing for the sole benefit of RAS and shall not disclose it to, or use or reproduce it for any third party, or perform any act adverse to the interest of RAS with respect to this drawing without the express written permission of RAS. Vendors shall not revise any physical, dimensional or performance characteristic unless authorized by Rev-A-Shelf Engineering.

REV.	DATE	BY	DESCRIPTION OF CHANGE

INCH [MM]	AMERICAN PROJECTION 	DRAWN	BY	DATE	REV-A-SHELF, INC.
			KRR	8-1-22	
					SIZE B
					448 SIDE SPICE HOLDER
					DRAWING NO. 448-BSKS-3C
					SCALE 0.200
					FINISH
					PART NO. 448-BSKS-3C
					SHEET 2 OF 2

TOLERANCES
 MAT. DEC.
 (WOOD) .XX ±.03 [.8mm]
 (OTHER) .XX ±.02 [.5mm]
 (ALL) .XXX ±.005 [.13 mm]
 FRACTIONS ±1/32 [.8 mm]

ANGLES
±1/2°