



WARNING

- To reduce the risk of death, personal injury or property damage from fire, electric shock, falling parts, cuts/abrasions, and other hazards read all warnings and instructions included with and on the fixture box and all fixture labels.
- Before installing, servicing, or performing routine maintenance upon this equipment, follow these general precautions.
- Commercial installation, service and maintenance of luminaires should be performed by a qualified licensed electrician.
- For the installation: If you are unsure about the installation or maintenance of the luminaires, consult a qualified licensed electrician and check your local electrical code.
- To prevent wiring damage or abrasion, do not expose wiring to edges of sheet metal or other sharp objects.
- Do not make or alter any open holes in an enclosure of wiring or electrical components during kit installation.
- Turn off electrical power at fuse or circuit breaker box before wiring fixture to the power supply.
- Turn off the power when you perform any maintenance.
- Verify that supply voltage is correct by comparing it with the luminaire label information.
- All wiring connections should be capped with UL approved wire connectors.

ATTENTION

- Avoid direct eye exposure to the light source while it is on.
- Account for small parts and destroy packing material, as these may be hazardous to children.
- Risk of burn. Disconnect power and allow fixture to cool before changing bulb or handing fixture.
- NOTICE: Green ground screw provided in proper location. Do not relocate.
- NOTICE: Minimum 90°C supply conductors.
- NOTICE: Specifications and dimensions subject to change without notice.
- NOTICE: Suitable for Dry or Damp location

SAVE THESE INSTRUCTIONS

What's In The Box

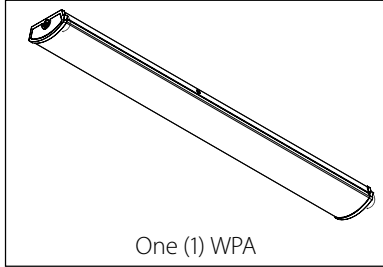

Tools & Materials Needed

A screwdriver, drill, wire cutters, four (4) screws, and four (4) anchors will be needed to install the WPA.

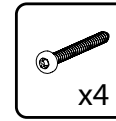
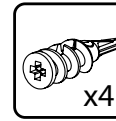
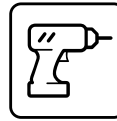
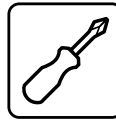

GENERAL STEPS

Carefully unpack fixture from packaging and inspect for any damage caused in shipping.

Turn off power to appropriate circuit at the breaker panel.

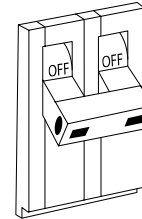

STEP 1: FIXTURE PREPARATION

To open the light fixture, gently pull down on the cover until the internal clips release. The fixture will then swing open on its hinge brackets for easy access.

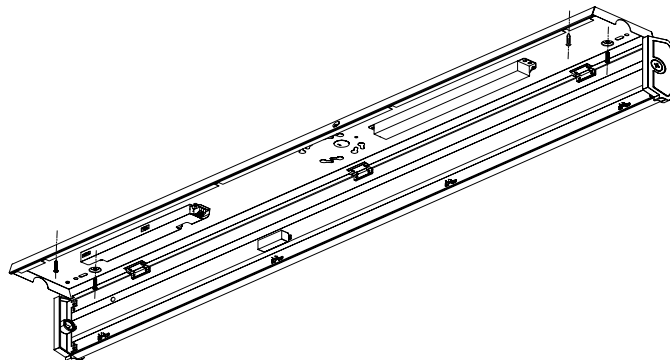

STEP 2: SURFACE PREPARATION

The WPA can be mounted directly to a surface OR mounted directly to a junction box. To mount directly to the surface use the luminaire housing as a template and line up the power feed hole with the junction box. Then mark the locations of the four (4) Outer Mounting screw holes on the mounting surface. If necessary, install anchors at the marked locations.

STEP 3: INSTALL FIXTURE

If mounting directly to surface, place fixture against mounting surface and install four (4) screws into standoff locations.

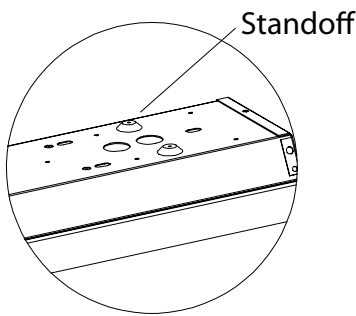

If mounting to junction box, insert two screws into junction box tabs. Align fixture keyholes to screws insert over screws and turn to lock into place. Fully tighten screws.

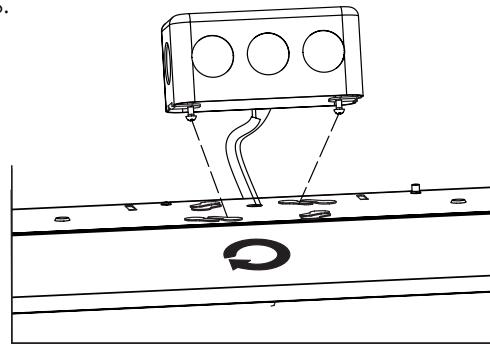

If suspension mounting, chose method of suspension, V-hook & Chain or Cable. See fixture spec sheet for mounting accessory part numbers.

For chain, insert the v-hook ends into the holes on the back of the fixture and attach to chain securely fastened to structure.

For cable, insert the paddle ends of the cable into the holes on the back of the fixture and attach to cable securely fastened to structure. Wire using FMC or other approved wiring per the wiring diagram.

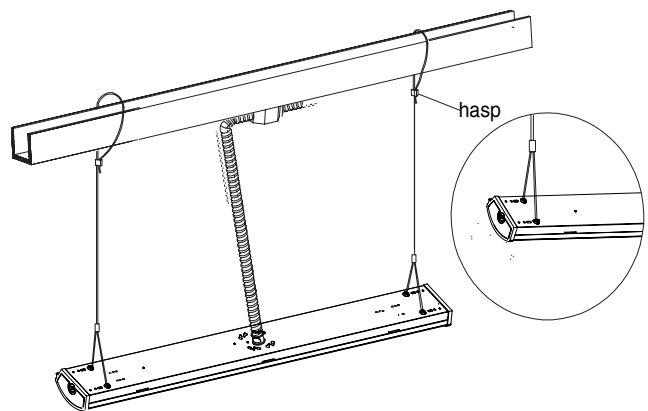
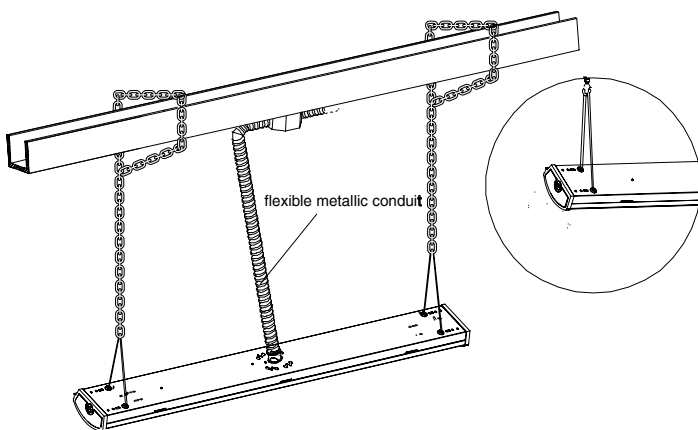

STEP 4: ELECTRICAL CONNECTIONS

Make electrical connections per the wiring diagram.

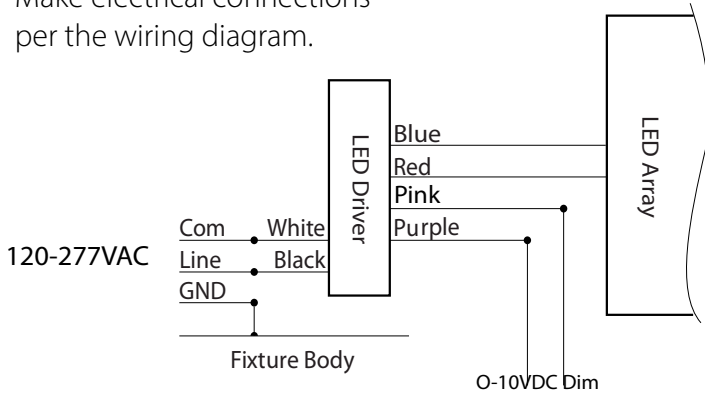

STEP 5: WATTAGE/CCT SELECTION

Prior to closing the fixture, adjust the fixture settings

To adjust CCT or Wattage (lumen output), slide the switches on the driver case that corresponds to the desired settings.

Note:

- 1) Power selection switch is a three-position switch that will adjust light output: 25W/35W/45W
- 2) CCT selection switch is a five-position switch that will adjust Color Temperature between 3000K, 3500K, 4000K, 5000K or 6500K.
- 3) Default setting is 25W power and 4000K CCT.

STEP 6: MOTION SENSOR INSTALLATION

- Remove the knockout, then align and push the sensor into the opening until the side retaining clips snap securely into place.
- Plug the existing sensor wiring harness into the back of the sensor.

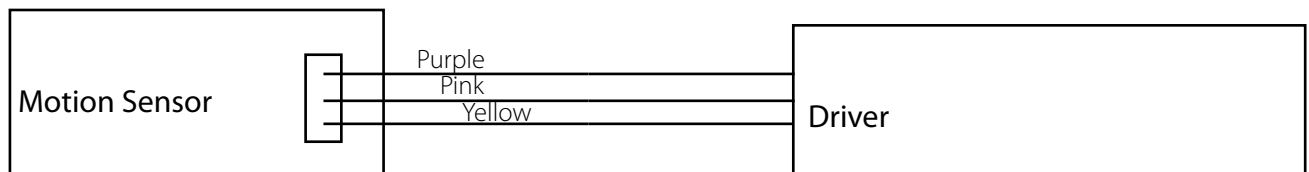

STEP 7: REINSTALL LENS

Swing the fixture closed and press firmly until the clips snap securely into place.

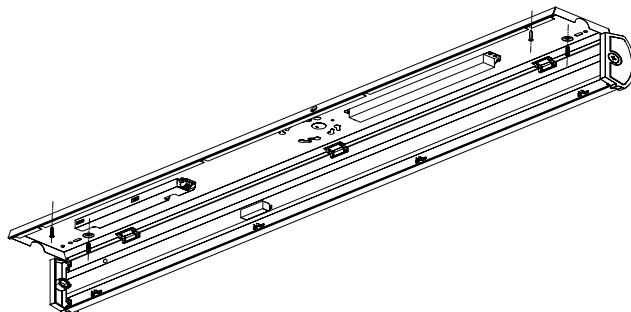

STEP 8: ELECTRICAL CONNECTIONS with EMERGENCY BATTERY

The battery pack is preinstalled from the factory. The only connections required are line voltage, emergency line voltage, and dimming lines as needed.

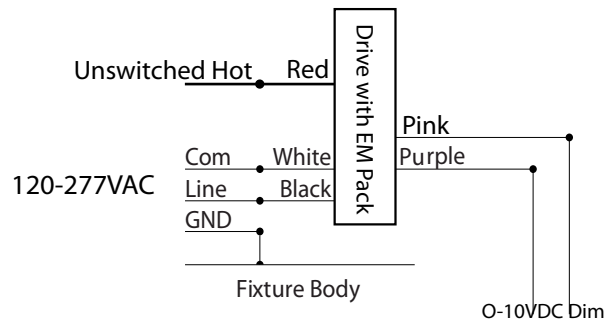

This device complies with part 15 of the FCC Rules. Operation is subject to the following two conditions: (1) This device may not cause harmful interference, and (2) this device must accept any interference received, including interference that may cause undesired operation.

NOTE: This equipment has been tested and found to comply with the limits for a Class A digital device, pursuant to part 15 of the FCC Rules. These limits are designed to provide reasonable protection against harmful interference when the equipment is operated in a commercial environment. This equipment generates, uses, and can radiate radio frequency energy and, if not installed and used in accordance with the instruction manual, may cause harmful interference to radio communications. Operation of this equipment in a residential area is likely to cause harmful interference in which case the user will be required to correct the interference at his own expense.

NICOR LED Express Limited Warranty

Subject to the exclusions below, each NICOR LED product, including the LED electronics and components of a property installed NICOR LED product, will be free from defect in materials and workmanship for a period of five (5) years from the original date of purchase. The product shall be considered defective only if 10% or more of the product's LED components fail. NICOR LED product warranty covers the following performance criteria: LED Light Output will be maintained above 70% of initial output; LED color temperature will not shift more than 200K in CCT; LED driver will operate within NICOR specifications; and the fixture finish, excluding natural aluminum or brass products, will not exhibit cracking, peeling, excessive fading, or corrosion during the warranty period. Exceptions apply as defined in NICOR's product specification sheets, which are incorporated by reference herein. This limited warranty is provided to you, the purchaser of the product identified on Seller's invoice, as your exclusive remedy and applies only to NICOR products that have been purchased from an authorized NICOR Distributor; the product was new and in an unopened NICOR package at the time of installation; and the NICOR product was installed by a licensed electrician or under the supervision of a licensed electrician and used by consumers in the United States or Canada when accompanied with this warranty. This warranty extends only to the first consumer purchaser and is not transferable. A consumer wishing to invoke the terms of this limited warranty must first obtain a RGA number within 30 days of discovery of the defect, and return the product to NICOR for inspection. Once verified to be covered by this limited warranty, NICOR will, at its sole discretion, repair, replace, or refund the purchase price of any product that does not conform to this limited warranty. If NICOR, at its sole discretion, determines that the product should be repaired or replaced, this warranty is limited to the reasonable, customary, and necessary costs and expenses associated with the repair/replacement. This warranty requires that all repair/replacement estimates and costs, including but not limited to equipment rental (if any), and any other cost or expense to be incurred in the repair/replacement of the product, be approved in advance and in writing by NICOR.

FAILURE TO OBTAIN NICOR'S ADVANCE WRITTEN APPROVAL OF ALL REPAIR/REPLACEMENT COSTS AND EXPENSES IN WRITING SHALL VOID THIS LIMITED WARRANTY. THIS LIMITED WARRANTY DOES NOT COVER THE FOLLOWING:

- Defects or damages resulting from improper installation, operation, storage, misuse or abuse, accident, or neglect;
- Defects or damages resulting from improper service, testing, adjustment, installation, maintenance, alteration, connection to out-of-specification electrical service, corrosive or damp environments, or connection to incompatible equipment or devices (e.g., connecting non-dimmable lighting products to dimmers);
- Damage which occurs in transit;
- Power surges or overheating due to external conditions
- Acts of nature including but not limited to lightning strikes

ANY IMPLIED WARRANTIES, INCLUDING WITHOUT LIMITATION, THE IMPLIED WARRANTIES OF MERCHANTABILITY AND FITNESS FOR A PARTICULAR PURPOSE SHALL BE LIMITED TO THE DURATION OF THIS LIMITED WARRANTY, OTHERWISE THE REPAIR, REPLACEMENT, OR REFUND AS PROVIDED UNDER THIS EXPRESS LIMITED WARRANTY IS THE EXCLUSIVE REMEDY OF THE CONSUMER, AND IS PROVIDED IN LIEU OF ALL OTHER WARRANTIES, EXPRESS OR IMPLIED. IN NO EVENT SHALL NICOR BE LIABLE, WHETHER IN CONTRACT OR IN TORT (INCLUDING NEGLIGENCE) FOR DAMAGES IN EXCESS OF THE PURCHASE PRICE OF THE PRODUCT, OR FOR ANY INDIRECT, INCIDENTAL, SPECIAL OR CONSEQUENTIAL DAMAGES OF ANY KIND, OR LOSS OF REVENUE OR PROFITS, LOSS OF BUSINESS OR OTHER FINANCIAL LOSS ARISING OUT OF OR IN CONNECTION WITH THE ABILITY OR INABILITY TO USE THE PRODUCT TO THE FULL EXTENT THESE DAMAGES MAY BE DISCLAIMED BY LAW.