

DETAIL A
SCALE 0.250

CUSTOMER DRAWING

This drawing is the property of Rev-A-Shelf (RAS) and is disclosed in confidence to the extent its subject matter is original to RAS. Any vendor receiving this drawing from RAS shall hold and use this drawing for the sole benefit of RAS and shall not disclose it to, or use or reproduce it for any third party, or perform any act adverse to the interest of RAS with respect to this drawing without the express written permission of RAS. Vendors shall not revise any physical, dimensional or performance characteristic unless authorized by Rev-A-Shelf Engineering.

REV.	DATE	BY	DESCRIPTION OF CHANGE

INCH [MM]	AMERICAN PROJECTION 	DRAWN	BY	DATE	REV-A-SHELF, INC.
		LCS	8-2-23	SIZE B	
TOLERANCES		MATERIAL	DRAWING NO.		SCALE
MAT.	DEC.		CPUIBSL-14-SM-1		0.125
(WOOD)	.XX ±.03 [.8mm]	FINISH	PART NO.		SHEET OF
(OTHER)	.XX ±.02 [.5mm]		CPUIBSL-14-SM-1		
(ALL)	.XXX ±.005 [.13 mm]				
FRACTIONS	±1/32 [.8 mm]				

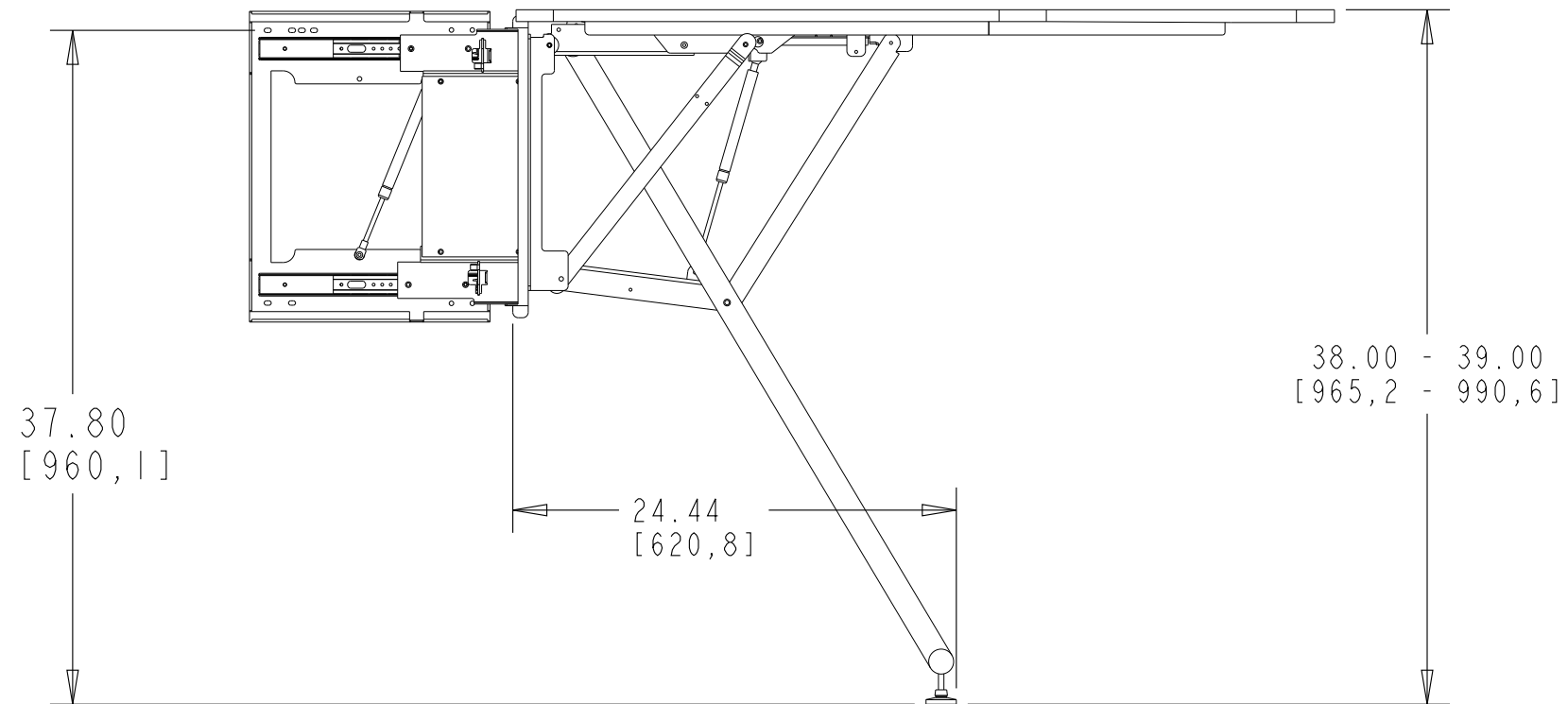
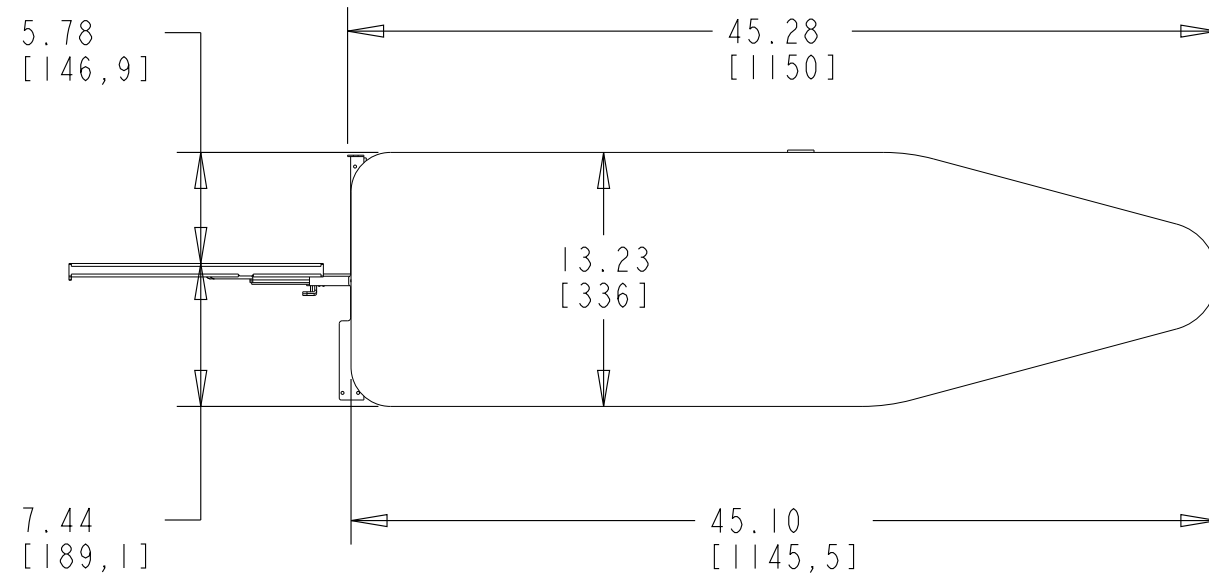

CUSTOMER DRAWING

This drawing is the property of Rev-A-Shelf (RAS) and is disclosed in confidence to the extent its subject matter is original to RAS. Any vendor receiving this drawing from RAS shall hold and use this drawing for the sole benefit of RAS and shall not disclose it to, or use or reproduce it for any third party, or perform any act adverse to the interest of RAS with respect to this drawing without the express written permission of RAS. Vendors shall not revise any physical, dimensional or performance characteristic unless authorized by Rev-A-Shelf Engineering.

REV.	DATE	BY	DESCRIPTION OF CHANGE

INCH [MM]	AMERICAN PROJECTION 	DRAWN	BY	DATE	REV-A-SHELF, INC.
			LCS	8-2-23	
					SIZE B
					DRAWING NO. CPUIBSL-14-SM-1
					SCALE 0.125
					PART NO. CPUIBSL-14-SM-1
					SHEET OF 2 OF 3

TOLERANCES
 MAT. DEC.
 (WOOD) .XX ±.03 [.8mm]
 (OTHER) .XX ±.02 [.5mm]
 (ALL) .XXX ±.005 [.13 mm]
 FRACTIONS ±1/32 [.8 mm]

ANGLES
 ±1/2°

MATERIAL
 FINISH

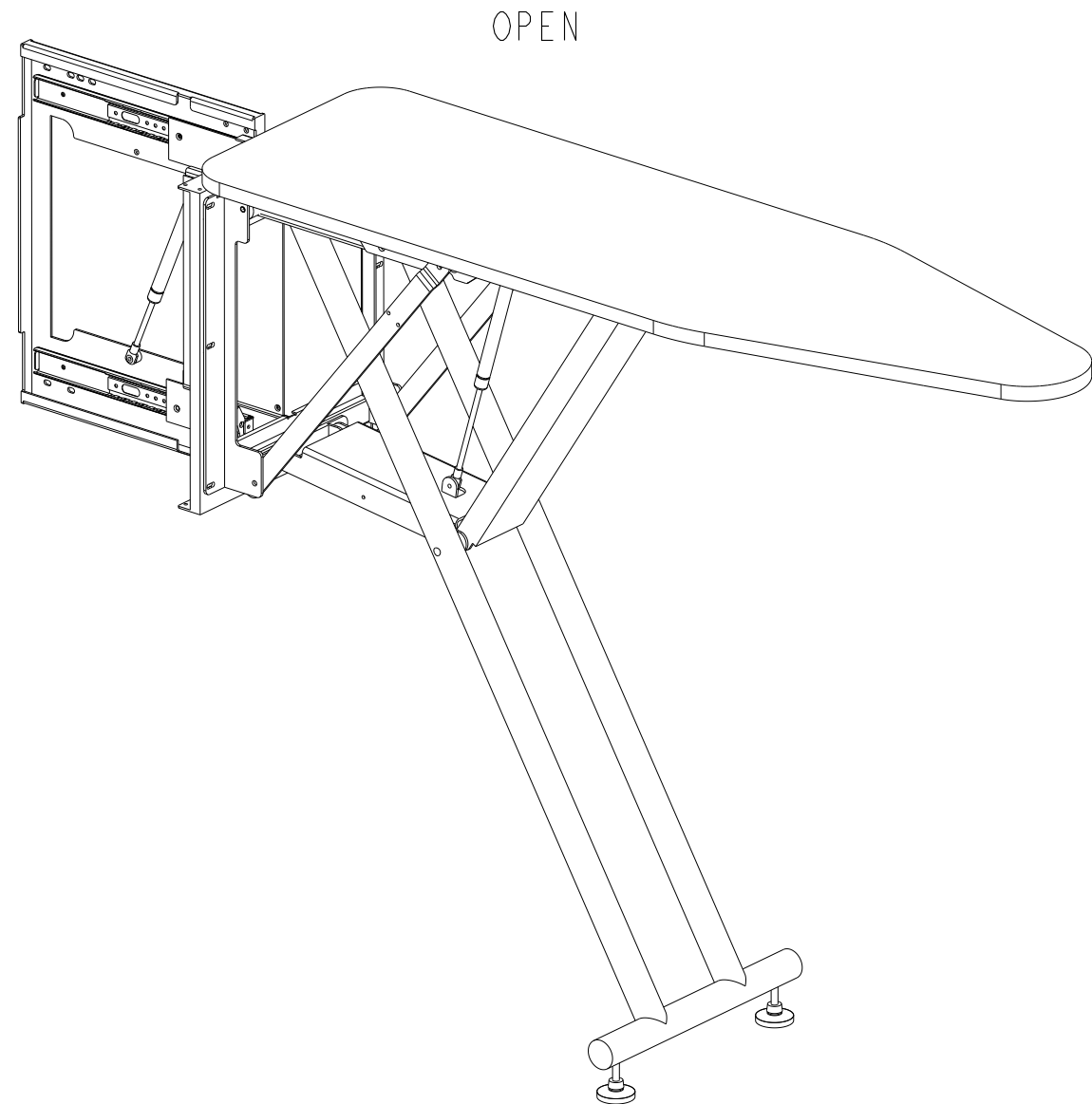

OPEN

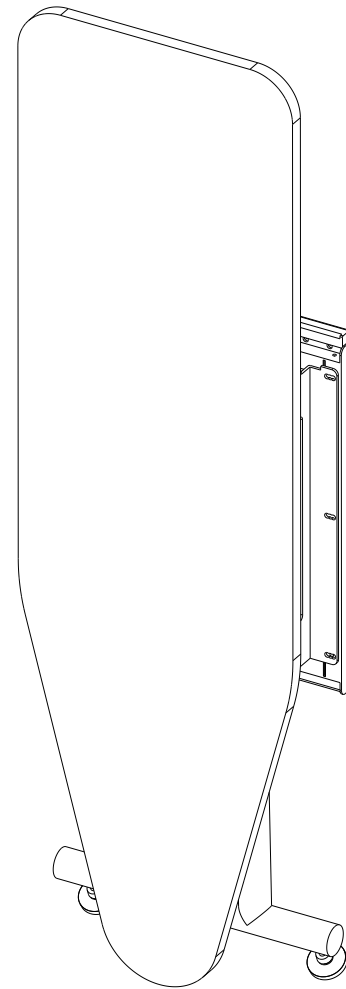

CLOSED

PART DIMENSIONS	
WIDTH	5.60 [142,3]
DEPTH	13.82 [351]
HEIGHT	45.10 [1145,5]

MIN CABINET OPENING	
WIDTH	10.00 [254]
DEPTH	14.00 [355,6]
HEIGHT *	47.00 [1193,8]

* TOP OF OPENING: 54.00 [1371,6]
FROM FLOOR

SLIDE SPECIFICATIONS			
SLIDE TYPE	BALL BEARING	SLIDE EXTENSION	OVER-TRAVEL
SLIDE CLOSING	SOFT	SLIDE LENGTH	305MM
SLIDE MOUNTING	WALL	SLIDE FINISH	ZINC

CUSTOMER DRAWING

This drawing is the property of Rev-A-Shelf (RAS) and is disclosed in confidence to the extent its subject matter is original to RAS. Any vendor receiving this drawing from RAS shall hold and use this drawing for the sole benefit of RAS and shall not disclose it to, or use or reproduce it for any third party, or perform any act adverse to the interest of RAS with respect to this drawing without the express written permission of RAS. Vendors shall not revise any physical, dimensional or performance characteristic unless authorized by Rev-A-Shelf Engineering.

REV.	DATE	BY	DESCRIPTION OF CHANGE

INCH [MM]	AMERICAN PROJECTION 	DRAWN	BY	DATE	REV-A-SHELF, INC.
			LCS	8-2-23	
			MATERIAL	DRAWING NO.	SCALE
			FINISH	CPUIBSL-14-SM-1	0.125
			PART NO.		SHEET OF
			CPUIBSL-14-SM-1		3 OF 3

TOLERANCES
 MAT. DEC.
 (WOOD) .XX ±.03 [.8mm]
 (OTHER) .XX ±.02 [.5mm]
 (ALL) .XXX ±.005 [.13 mm]
 FRACTIONS ±1/32 [.8 mm]

ANGLES
 ±1/2°