

LED Tube Retrofit Solution

Commercial Refrigeration Case
Horizontal (C Type)



Canopy Lighting

48-INCH:

- GELED15T8/4/830/RCC
- GELED15T8/4/835/RCC
- GELED15T8/4/840/RCC
- GELED15T8/4/850/RCC

Undersshelf Lighting

48-INCH:

- GELED06T8/4/830/RUC
- GELED06T8/4/835/RUC
- GELED06T8/4/840/RUC
- GELED06T8/4/850/RUC



BEFORE YOU BEGIN

Read these instructions completely and carefully.

FOR YOUR SAFETY

Read and observe all **CAUTIONS** and **WARNINGS** shown throughout these instructions.

- Installation to be performed by factory trained service personnel only.
- For use inside a commercial refrigeration case.
- This LED Tube is intended to replace the corresponding length fluorescent tube with a G13 lamp base.
- Use this unit only in the manner intended by the manufacturer. If you have any questions, contact the manufacturer.
- Before installing, servicing or cleaning unit, switch power off at the service panel and follow appropriate lock out/tag out safety procedures.
- Suitable for damp location.

OPERATING TEMPERATURE

- Minimum is -20°C
- Maximum is 25°C
- Maximum TC point is 55°C

LED DRIVER COMPATIBILITY

This system is compatible with GE LED Drivers
GEPS6100NCCON-SY, GEPS6500NCMUL-SY,
GELP24-100U-GL, GELP24-100U-GLX, GELP24-60U-GL

⚠ CAUTION / ATTENTION

RISK OF INJURY

- Tube may fall down if not installed properly, follow installation instructions.
- While performing installations described, gloves, safety glasses or goggles should be worn.

RISK OF PRODUCT DAMAGE

- Adequately IP rated lamp holders are required for applications requiring ingress protection ratings up to the IP65 rating of the lamp.
- Do not replace conventional LFL directly with Immersion LED tubes. Immersion LED tubes need a DC voltage to work.
- This lamp may not be suitable for use in all applications where a traditional fluorescent lamp has been used. The temperature range of this lamp is more restricted. In cases of doubt regarding the suitability of the application the manufacturer of this lamp should be consulted.

⚠ WARNING / AVERTISSEMENT

- Luminaire wiring and electrical parts may be damaged when drilling for installation of LED retrofit kit. Check for enclosed wiring and components.
- Disconnect power before servicing or installing product
- Immersion LED Tubes requires knowledge of luminaires electrical systems. If not qualified, do not attempt installation. Contact a qualified electrician.
- Install this product only in the luminaires that have the construction features and dimensions shown in the photographs and/or drawings.
- Do not alter, relocate, or remove wiring, lampholders, power supply, or any other electrical component.
- Installers should not disconnect existing wires from lampholder terminals to make new connections at lampholder terminals. Instead installers should cut existing lampholder leads away from the lampholder and make new electrical connections to lampholder lead wires by employing applicable connectors.
- This product must be installed in accordance with the applicable installation code by person familiar with the construction and operation of the product and hazards involved.
- The retrofit assembly is accepted as component of a luminaire where the suitability of the combination shall be determined by UL or authorities having jurisdiction.

Tools Required

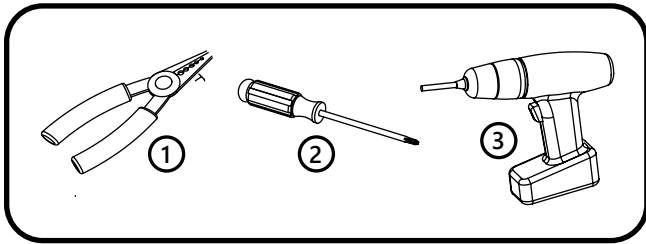

- ① Wire Stripper/Cutter
- ② Screwdriver
- ③ Cordless drill with driver bit

Components Required

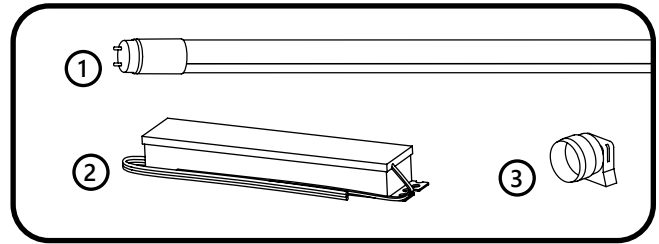

- ① LED Tube
- ② LED Driver
- ③ Optional Plastic Cover (93038792)

⚠ WARNING / AVERTISSEMENT

Risk of fire or electric shock. Luminaire wiring and electrical parts may be damaged when drilling for installation of LED retrofit kit. Check for enclosed wiring and components.

Risque de feu ou électrocution. Les pièces et câbles électriques risquent d'être endommagés lors du perçage des trous pour l'installation du luminaire à DEL. Veuillez vérifier si des câbles et composantes se trouvent derrière la paroi avant de percer.

To prevent wiring damage or abrasion, do not expose wiring to edges of sheet metal or other sharp objects.

Pour éviter l'endommagement de câblage ou l'abrasion, ne pas exposer le câblage aux bords de feuilles de métal ou d'autres objets tranchants.

Components Installation (for OEM install, proceed to Step 2)

① Remove Existing Lighting Components

- Refer to manufacturing manual for refrigeration case to identify lighting control circuits. Ensure that power is switched off at the service panel for the lighting circuit. If a lighting power switch is not provided in the refrigeration case, power removal can be performed at the main breaker panel.
- Locate ballast within system. The most common location is in the canopy or on the top of the case.
- Disconnect ballast input and output connectors. Cut the ballast connector wires nearest to the connector and remove connector. Unscrew the mounting screws that attach ballast and remove ballast
- To install the LED light, first identify the wiring for connection to the LED driver. After removing the connector from ballast, leave the existing ballast input and output wires for reconnection in a later step.

② Remove Existing Fluorescent Lamps

- Remove existing fluorescent lamps and dispose of them properly based in local regulations.
- Leave wiring in place and make sure wire length is long enough to attach to the new LED driver. Verify that the AC supply line is provided with a ground wire connected to the refrigerator.
- Secure GE driver to fixture by using existing ballast mounting holes and screws. Use self-tapping screws (not provided) to create new mounting holes if necessary.

Fluorescent Component Location

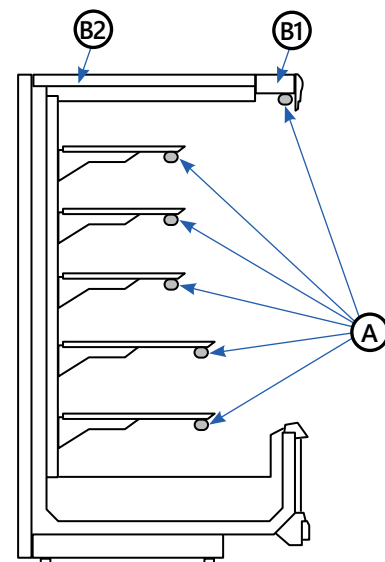

- Ⓐ Lamp and lamp holders
- Ⓑ Ballast
 - 1. Canopy
 - 2. Top of case

3 Select Installation Position

- Select installation position: Undershef or Canopy.

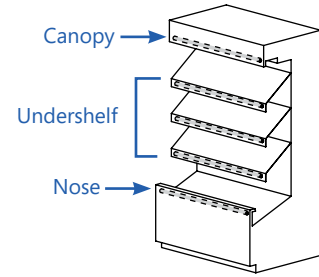

4 Connect LED Driver Output

- For retrofit, place LED driver in the location where the ballast was formerly located.
- Driver must be enclosed and located at least 20cm (7 in.) away from compressor.
- Make output (DC) connections using one of the two options below:

Option 1: Using 4-Way Connector

Connect the LED Driver output leads to the LED leads using the appropriate mating connector (Molex P/N 39-01-4046). Terminals installed should be crimped using approved tooling and process per Molex specifications.

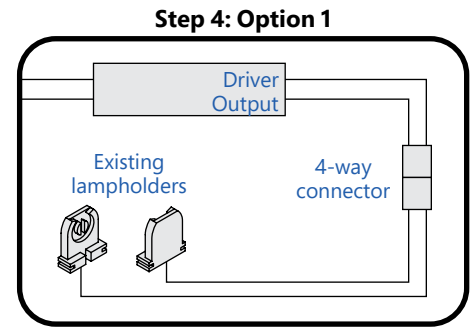

Option 2: Using Twist-On Wire Connector

Remove the 4-way connector from the LED Driver by cutting the wires near the connector and the strip the output leads. Connect the LED Driver output leads to the leads leading to the fluorescent lamp holders for the LED tubes that the driver is intended to power using wire connectors or other connection method approved for low temperature usage and stranded cable. The red (+) LED Driver lead shall be connected to the leads for the lamp holders at one end of each LED tube, and the black (-) shall be connected to the leads for the lamp holders at the opposite end of each LED tube.

For non-dimming applications, cap the unused wires with 5/32" (4mm) twist on wire connectors.

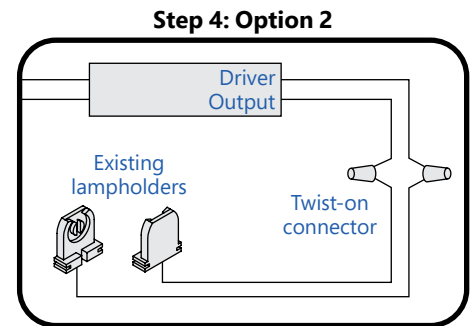

5 Connect LED Driver Input

- The LED Driver is required to be reliably bonded to the protective ground conductor.
- The power supply must be connected to an individual properly grounded branch circuit, protected by a 15 or 20 ampere circuit breaker or time delay fuse.
- Make input (AC) connections using one of the two options below:

Option 1: Using 2-Way Connector

Attach the supplied green/yellow ground wire from the LED Driver to a grounded metal portion of the door frame. Connect the original line and neutral wires (or Line 1 and Line 2 wires for 240 nominal VAC) to the 3-way connector for the LED Driver input wires using the appropriate mating connector (Molex P/N 39-01-4030).

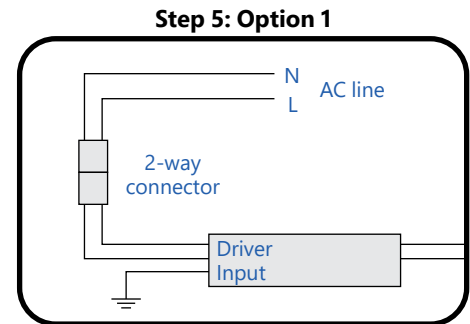

Option 2: Using Twist-On Wire Connectors

Attach the supplied green/yellow ground wire from the LED Driver to a grounded metal portion of the door frame. Remove the 3-way connector from the LED Driver by cutting the wires near the connector and strip the input wires. Connect the original line and neutral wires (or Line 1 and Line 2 wires for 240 nominal VAC) to the LED Driver leads using twist lock wire connectors or other connection method approved for low temperature usage and stranded cable.

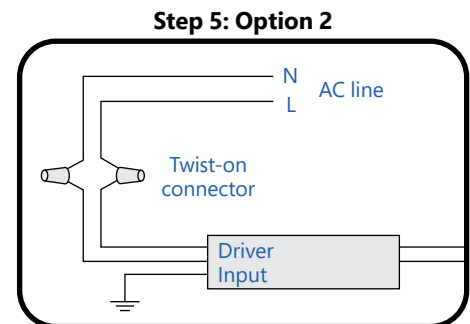

One LED Tube with One LED Driver

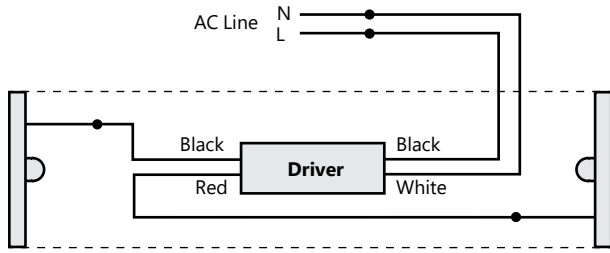

Multiple LED Tubes with One LED Driver

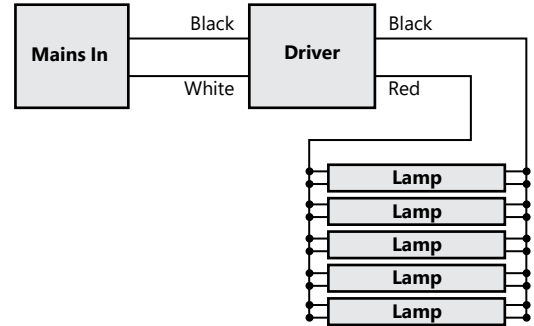

Minimum and Maximum LED Driver Loading Specifications

	DC Watts	GEP6500NCMUL-SY		GEP6100NCCON-SY		GELP24-60U-GL		GELP24-100U-GL, GELP24-100U-GLX	
		Min.	Max.	Min.	Max.	MIN.	Max.	Min.	Max.
GELED15T8/4/830/RCC	15 w	2	3	3	5	2	3	3	5
GELED15T8/4/835/RCC	15 w	2	3	3	5	2	3	3	5
GELED15T8/4/840/RCC	15 w	2	3	3	5	2	3	3	5
GELED15T8/4/850/RCC	15 w	2	3	3	5	2	3	3	5
GELED06T8/4/830/RUC	6 w	3	7	4	14	4	9	4	14
GELED06T8/4/835/RUC	6 w	3	7	4	14	4	9	4	14
GELED06T8/4/840/RUC	6 w	3	7	4	14	4	9	4	14
GELED06T8/4/850/RUC	6 w	3	7	4	14	4	9	4	14

⚠ WARNING / AVERTISSEMENT

Risk of electrical shock. Ensure that all connection points are sealed for damp location using the appropriate method per the NEC or local electrical code.

Risque de choc électrique. S'assurer que les points de raccordements sont scellés pour emplacement humide en employant une méthode permise par le NEC ou par le code électrique local.

⚠ CAUTION / ATTENTION

Risk of injury. Do not overload LED Driver. Do not exceed limits shown in "Maximum LED Driver Loading" table below.

Risque de blessure. Ne pas surcharger l'alimentation. Ne pas exéder les limites de la table ci-dessous: "Charges maximales pour les alimentations."

⑥ Install LED Tubes

- Rotate LED tube to the desired position, then insert the Immersion LED tube in the lampholders to a secured position. Make sure LEDs are facing to desired direction. Repeat for remaining tubes.
- Restore power and ensure lamps are operating correctly.
- Affix the label which is provided inside the kit to the refrigerator where it can be easily noticed.

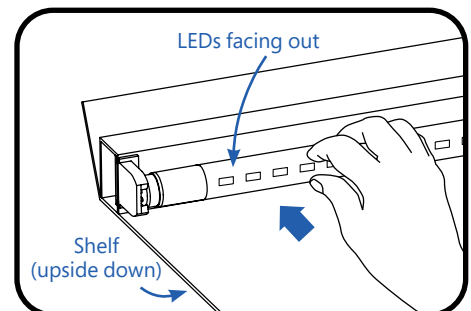

7 Optional Plastic Cover

- If using the optional plastic cover, insert the tube into the plastic cover. Make sure the two end cap pins align with to the two holes inside the plastic cover.
- Insert the two plastic covers for both ends of tube into the existing sockets.

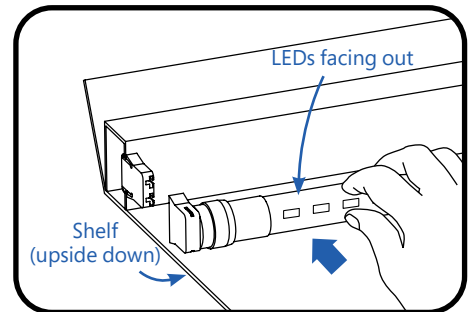
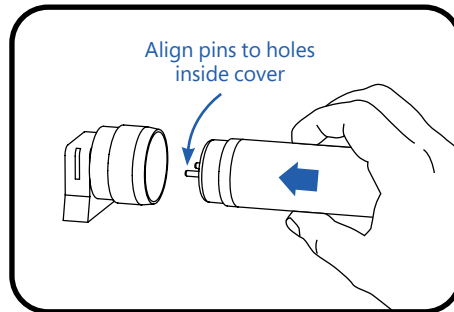

⚠ WARNING / AVERTISSEMENT

Risk of electrical shock. Disconnect power to LED Lights before any cleaning operation.

Risque de choc électrique. Débranchez l'alimentation des éclairages à LED avant toute opération de nettoyage.

8 Cleaning Instructions

- The LED Light may be dusted as needed with a dry, clean, soft cloth.
- Do not use chemical cleaners on the system.
- Do not wipe with a soiled dishcloth or wet towel—these may leave a residue that can damage the finish.
- Do not use scouring pads, powdered cleaning products, bleach or cleaners containing bleach because these products can scratch and damage the finish.

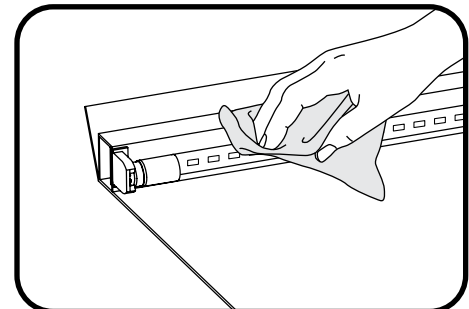

This device complies with part 15 of the FCC Rules. Operation is subject to the following two conditions: (1) This device may not cause harmful interference, and (2) this device must accept any interference received, including interference that may cause undesired operation.

This Class (A) RFLD complies with the Canadian standard ICES-005. Ce DEFR de la classe (A) est conforme a la NMB-005 du Canada.

NOTE: This equipment has been tested and found to comply with the limits for a Class A digital device, pursuant to part 15 of the FCC Rules. These limits are designed to provide reasonable protection against harmful interference when the equipment is operated in a commercial environment. This equipment generates, uses, and can radiate radio frequency energy and, if not installed and used in accordance with the instruction manual, may cause harmful interference to radio communications. Operation of this equipment in a residential area is likely to cause harmful interference in which case the user will be required to correct the interference at his own expense.

This product is intended solely for the use of commercial refrigerated, display or case lighting and is not intended for use in any other application.

Conforms to the following:



This lamp is not suitable to be used in emergency luminaires designed for double-capped fluorescent lamp(s).