

This drawing is the property of Rev-A-Shelf (RAS) and is disclosed in confidence to the extent its subject matter is original to RAS. Any vendor receiving this drawing from RAS shall hold and use this drawing for the sole benefit of RAS and shall not disclose it to, or use or reproduce it for any third party, or perform any act adverse to the interest of RAS with respect to this drawing without the express written permission of RAS. Vendors shall not revise any physical, dimensional or performance characteristic unless authorized by Rev-A-Shelf Engineering.

REV.	DATE	BY	DESCRIPTION OF CHANGE

INCH [MM]	AMERICAN PROJECTION 	DRAWN	BY	DATE	REV-A-SHELF, INC.
			BKT	9/19/22	
TOLERANCES					SIZE
MAT. DEC. (WOOD) .XX ±.03 [8mm] (OTHER) .XX ±.02 [5mm] (ALL) .XXX ±.005 [13 mm] FRACTIONS ±1/32 [8 mm]					B
ANGLES ±1/2°					DOUBLE 27QT PULL OUT
MATERIAL					DRAWING NO.
FINISH					4WCSC-1527DM-2_CUST
SCALE					0.250
PART NO.					SHEET OF
4WCSC-1527DM-2_CUST					1 2

CUSTOMER DRAWING

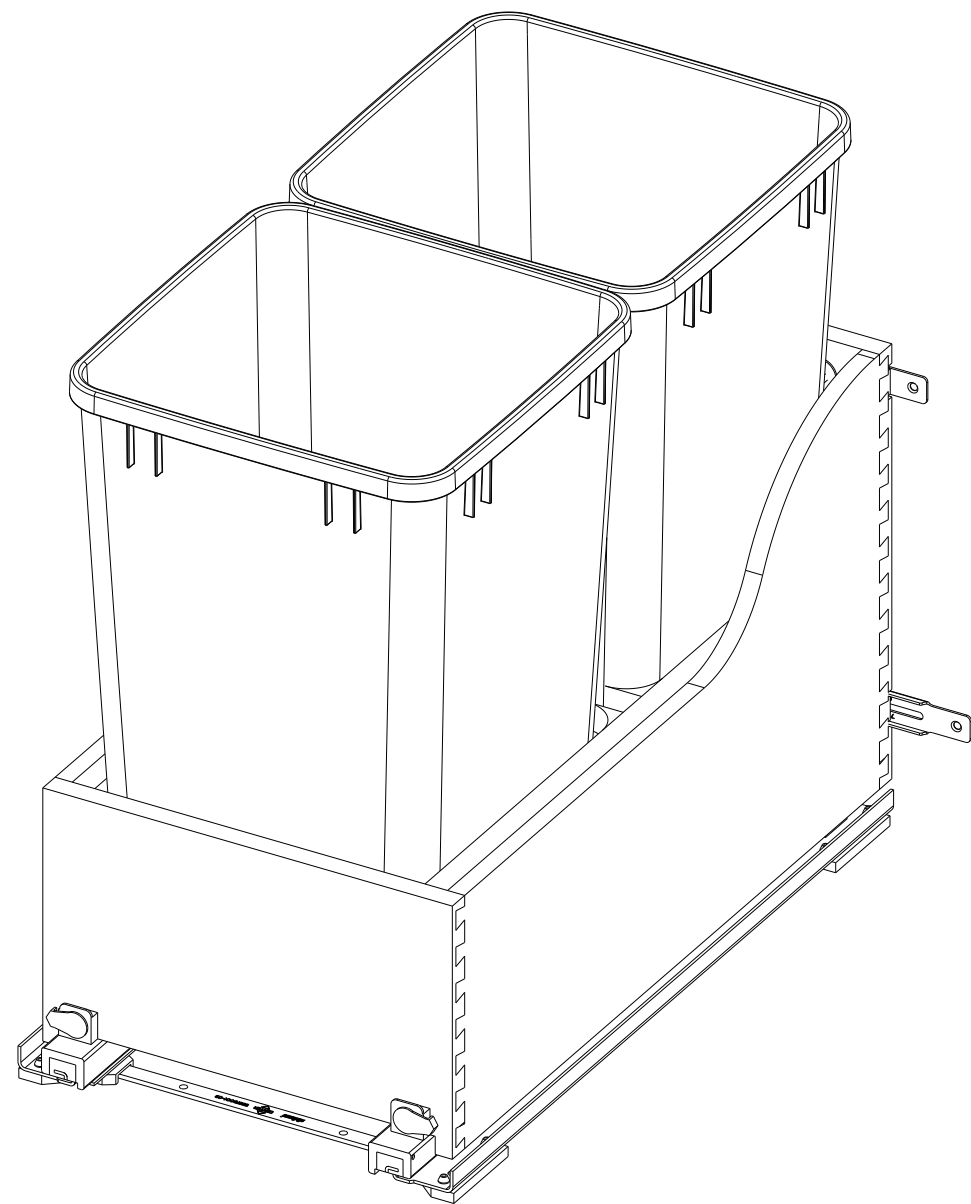

PART DIMENSIONS		
	MIN	MAX
WIDTH	12.00	
DEPTH	22.02	
HEIGHT	19.33	
WEIGHT		
DIAMETER		
RADIUS		
CONTAINER CAPACITY	27 EACH	
CONTAINER UOM	QUART	

MIN CABINET OPENING	
WIDTH	12.00
DEPTH	22.13
HEIGHT	19.50

PRODUCT MAX WEIGHT RATING

SLIDE SPECIFICATIONS				
SLIDE TYPE	UNDERMOUNT	SLIDE EXTENSION	FULL	MAX WEIGHT RATING
SLIDE CLOSING	SOFT	SLIDE LENGTH	21"	
SLIDE MOUNTING	BOTTOM	SLIDE FINISH	ZINC	110 LB

CUSTOMER DRAWING

This drawing is the property of Rev-A-Shelf (RAS) and is disclosed in confidence to the extent its subject matter is original to RAS. Any vendor receiving this drawing from RAS shall hold and use this drawing for the sole benefit of RAS and shall not disclose it to, or use or reproduce it for any third party, or perform any act adverse to the interest of RAS with respect to this drawing without the express written permission of RAS. Vendors shall not revise any physical, dimensional or performance characteristic unless authorized by Rev-A-Shelf Engineering.

REV.	DATE	BY	DESCRIPTION OF CHANGE

INCH [MM]	AMERICAN PROJECTION 	DRAWN	BY	DATE	REV-A-SHELF, INC.
			BKT	9/19/22	
TOLERANCES MAT. DEC. (WOOD) .XX ±.03 [.8mm] (OTHER) .XX ±.02 [.5mm] (ALL) .XXX ±.005 [.13 mm] FRACTIONS ±1/32 [.8 mm]		ANGLES ±1/2°	MATERIAL	DRAWING NO.	SCALE
FINISH	4WCSC-1527DM-2_CUST		0.375		
			PART NO.	SHEET OF	
			4WCSC-1527DM-2_CUST	2 2	