

OPEN VIEW

CUSTOMER DRAWING

This drawing is the property of Rev-A-Shelf (RAS) and is disclosed in confidence to the extent its subject matter is original to RAS. Any vendor receiving this drawing from RAS shall hold and use this drawing for the sole benefit of RAS and shall not disclose it to, or use or reproduce it for any third party, or perform any act adverse to the interest of RAS with respect to this drawing without the express written permission of RAS. Vendors shall not revise any physical, dimensional or performance characteristic unless authorized by Rev-A-Shelf Engineering.

REV.	DATE	BY	DESCRIPTION OF CHANGE
B	4-3-12	KRR	ECN12-020
A	9/22/11	BKT	ECN11-058

INCH [MM]	AMERICAN PROJECTION	DRAWN	BY	DATE	REV-A-SHELF, INC.	
			BKT	7/18/2011	SIZE	DRAWING NO.
					B	TIE RACK 12"
TOLERANCES			MATERIAL	DRAWING NO. TRC-12CR		
MAT. DEC. (WOOD) .XX ±.03 [8mm] (OTHER) .XX ±.02 [5mm] (ALL) .XXX ±.005 [13 mm] FRACTIONS ±1/32 [8 mm]			FINISH	PART NO. TRC-12CR		
ANGLES ±1/2°					SHEET OF 1 2	

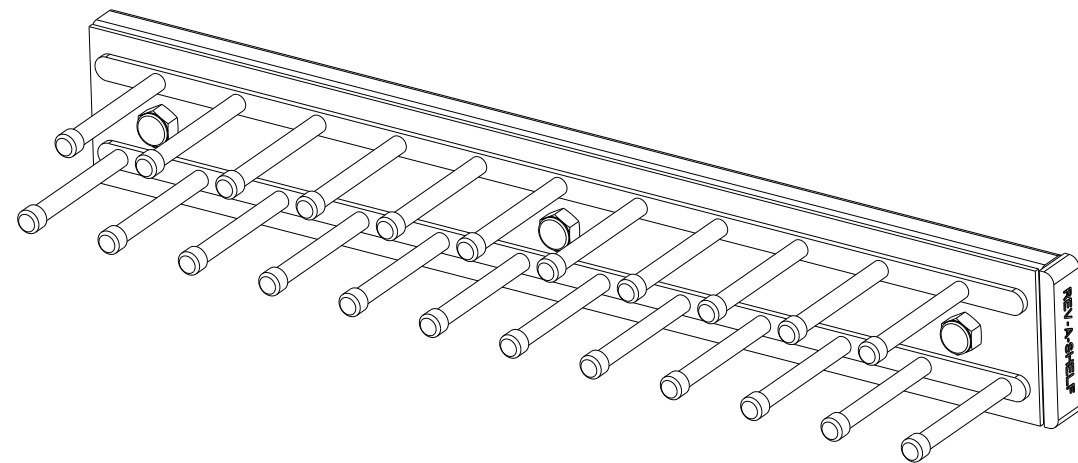

NOTE: HOLDS 23 TIES

PART DIMENSIONS		
	MIN	MAX
WIDTH	2.42	
DEPTH	11.99	
HEIGHT	1.82	
WEIGHT		
DIAMETER		
RADIUS		
CONTAINER CAPACITY		
CONTAINER UOM		

MIN CABINET OPENING	
WIDTH	2.50
DEPTH	12.00
HEIGHT	N/A

PRODUCT MAX WEIGHT RATING

SLIDE SPECIFICATIONS				
SLIDE TYPE	BALL BEARING	SLIDE EXTENSION	FULL	MAX WEIGHT RATING
SLIDE CLOSING	NORMAL	SLIDE LENGTH	300 MM	
SLIDE MOUNTING	SIDE	SLIDE FINISH		100 LB

CUSTOMER DRAWING

This drawing is the property of Rev-A-Shelf (RAS) and is disclosed in confidence to the extent its subject matter is original to RAS. Any vendor receiving this drawing from RAS shall hold and use this drawing for the sole benefit of RAS and shall not disclose it to, or use or reproduce it for any third party, or perform any act adverse to the interest of RAS with respect to this drawing without the express written permission of RAS. Vendors shall not revise any physical, dimensional or performance characteristic unless authorized by Rev-A-Shelf Engineering.

REV.	DATE	BY	DESCRIPTION OF CHANGE
B	4-3-12	KRR	ECN12-020
A	9/22/11	BKT	ECN11-058

INCH [MM]	AMERICAN PROJECTION 	DRAWN	BY	DATE	REV-A-SHELF, INC.
			BKT	7/18/2011	
				SIZE	TIE RACK 12"
				DRAWING NO.	TRC-12CR
				SCALE	0.500
				PART NO.	TRC-12CR
				SHEET OF	2 2

TOLERANCES
 MAT. DEC.
 (WOOD) .XX ±.03 [.8mm]
 (OTHER) .XX ±.02 [.5mm]
 (ALL) .XXX ±.005 [.13 mm]
 FRACTIONS ±1/32 [.8 mm]

ANGLES
 ±1/2°

MATERIAL

FINISH