

10-237(V) & 10-254(V)

Junior & Power-Lok Carpet Stretchers

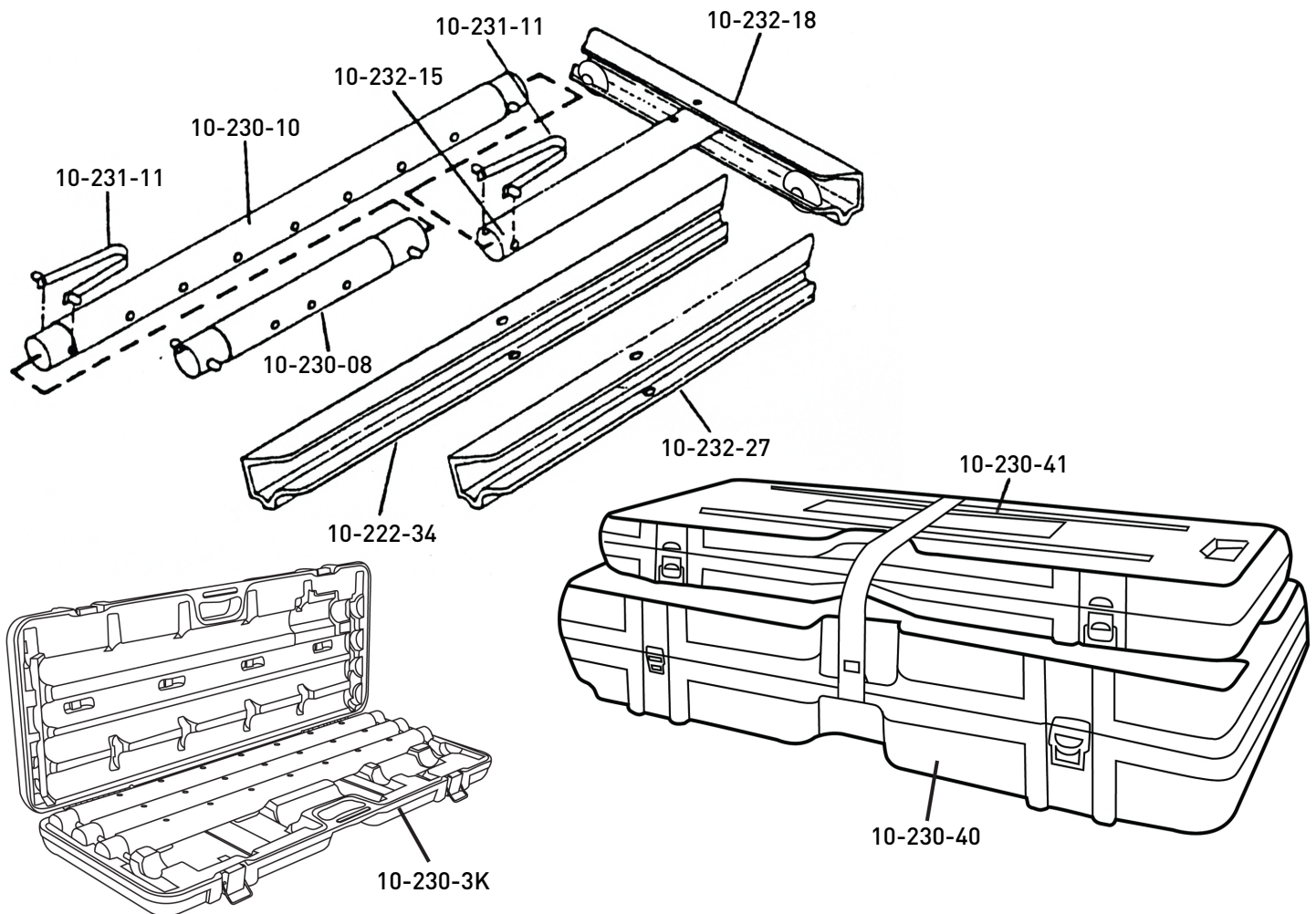

ACCESSORIES PARTS LIST

Part #	Description
10-230-40	Carpet Stretcher Case with Wheels
10-230-41	Empty Tube Case
10-230-3K	Case with Three 3' Extension Tubes
10-230-08	Connection Tube with Buttons
10-230-10	36 in. Steel Extension Tube
10-232-15	Tail Block Swivel Tube

Part #	Description
10-231-11	Spring Button for Extension Tubes
10-232-18	18 in. Tail Block with Cushion and Spring
10-232-19	18 in. Tail Block Cushion
10-222-34	34 in. Tail Block
10-232-27	26 in. Tail Block Cushion
10-235-05	5 ft. Aluminum Power Stretcher Tube

ACCESSORIES PARTS LIST

Part #	Description
10-235-10	3 ft. Aluminum Power Stretcher Tube
10-248	Nap Grip Head (Cotton Head)
10-250	34.5 in. Adjustable Locking Ext. Tube
10-258	Power Stretcher Tail
10-258-01	Power Stretcher Tail Pin

10-195

Heavy-Duty 6" Convertible Scraper

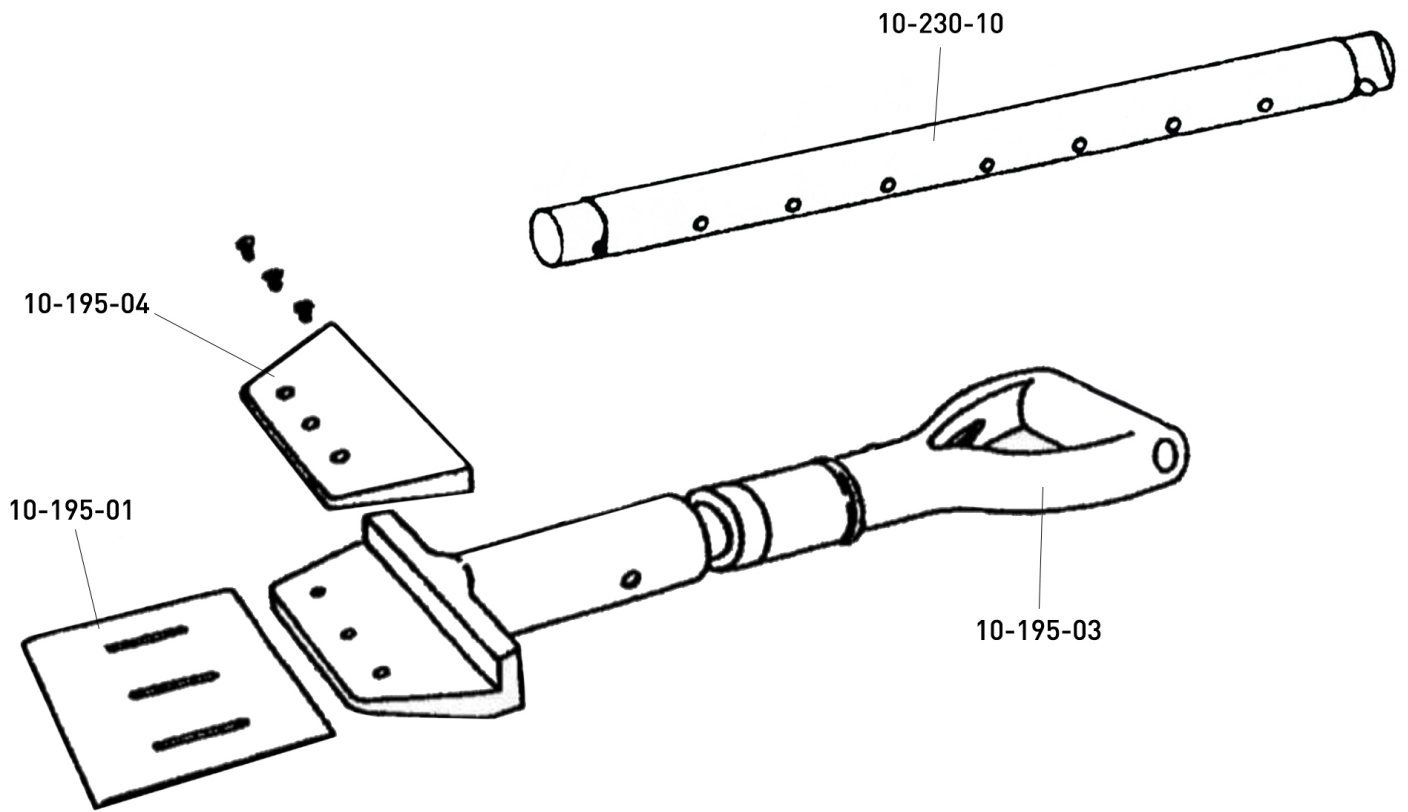

REPLACEMENT PARTS LIST

Part #	Description
10-195-01	Scraper Blade (without screws)
10-195-03	Complete Handle Assembly
10-195-04	Retainer Plate with screws
10-230-10	36" Steel Carpet Stretcher Extension Tube (sold separately)