





Thank you for choosing this quality product. Be sure to check all packaging materials carefully for small parts that may have become loose during shipment and place all parts on a non-abrasive surface.

IMPORTANT :These parts can be cumbersome and heavy to some people, therefore the assistance of two or more people is recommended in order to prevent personal injury and ensure the furniture is not damaged during the assembly Process.

PART LIST

- A [1] TABLETOP
- B[2] TABLELEAVES
- C[1] BASE

HARDWARELIST

NO	DESCRIPTION	QTY
1	 ALLEN HEAD BOLT	12
2	 LOCK WASHER	12
3	 PLAIN WASHER	12
4	 ALLEN WRENCH	1

INSTRUCTIONS

1. Bring the table top (A) and set it on the base (C). Align the fixed nuts at the bottom of the top to the holes on top of the base. Insert Allen bolts (1) through to Lock washers (2) and Flat washers (3) into each fixed nuts through the holes on top of the base, then tighten them by using Allen key (4). **DO NOT OVER TIGHTEN.** Refer to FIGURE 01.

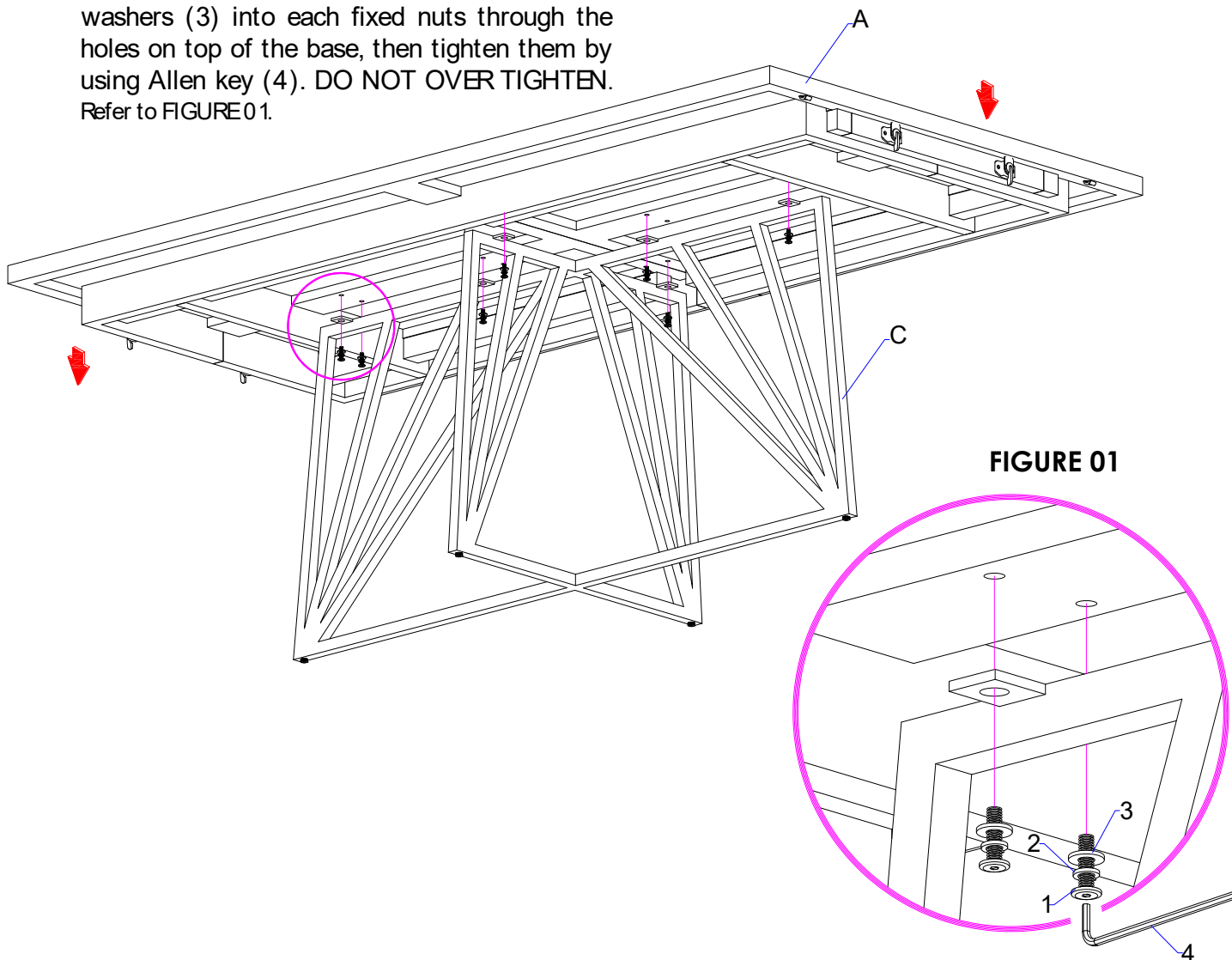

- Align and insert two leaves (B) to both ends of the table top (A). Secure these parts with the metal locks. See FIGURE 02 & 03.
- Check the table leveling, and adjust the levelers at the bottom of the base if necessary. See FIGURE 04.

FIGURE 02

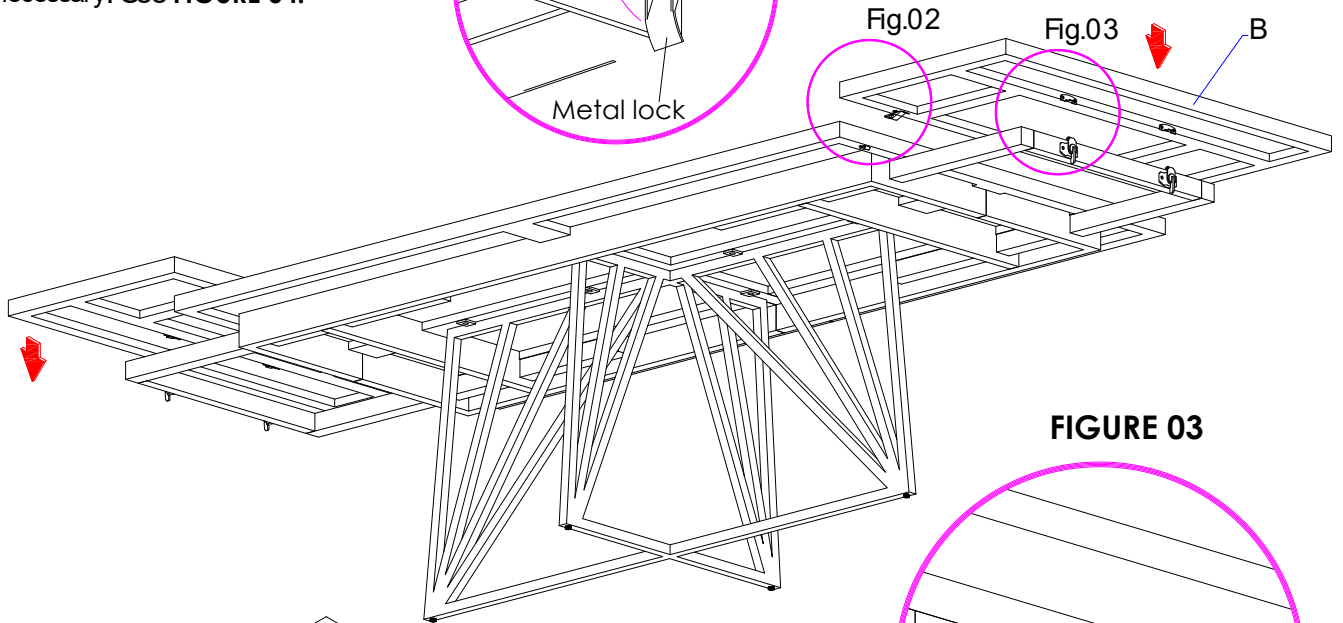
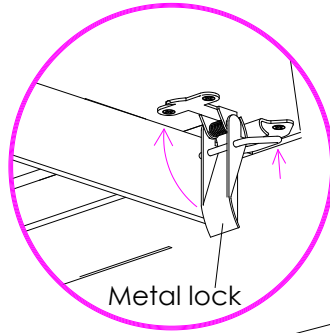

FIGURE 03

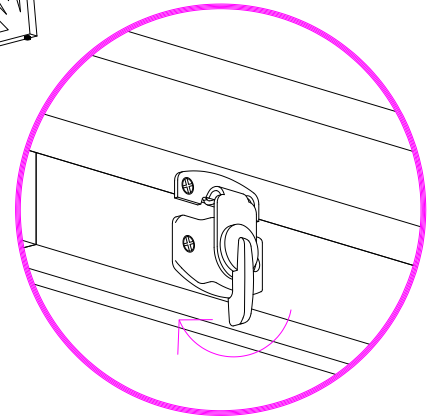
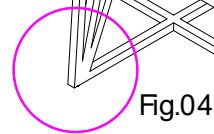
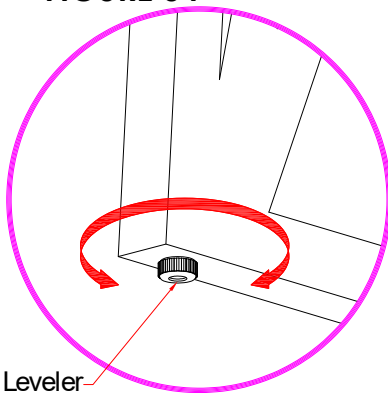

FIGURE 04



CARE INSTRUCTIONS

- Dust often using a clean, soft, dry and lint-free cloth.
- Blot spills immediately and wipe with a clean, damp, cloth.
- We do not recommend the use of chemical cleansers, abrasives or furniture polish on our lacquered finish.

IMPORTANT SAFETY INSTRUCTIONS

- Please read all instructions carefully before assembling.
- For your safety, assembly by two or more adults is strongly recommended.
- Keep instructions for future use.
- Use only vendor supplied hardware to assemble. Using unauthorized hardware could jeopardize the structural integrity of the item.