

CUSTOMER DRAWING

This drawing is the property of Rev-A-Shelf (RAS) and is disclosed in confidence to the extent its subject matter is original to RAS. Any vendor receiving this drawing from RAS shall hold and use this drawing for the sole benefit of RAS and shall not disclose it to, or use or reproduce it for any third party, or perform any act adverse to the interest of RAS with respect to this drawing without the express written permission of RAS. Vendors shall not revise any physical, dimensional or performance characteristic unless authorized by Rev-A-Shelf Engineering.

REV.	DATE	BY	DESCRIPTION OF CHANGE

INCH [MM]	AMERICAN PROJECTION	DRAWN	BY	DATE	REV-A-SHELF, INC.	
			KRR	1-2-23	SIZE B	DOUBLE 32 QT PULL OUT
TOLERANCES		ANGLES ±1/2°	MATERIAL	DRAWING NO.		SCALE
MAT.	DEC.			4VLWCSC-2432DM-2		0.150
(WOOD) .XX ±.03 [.8mm]			FINISH	PART NO.		SHEET OF
(OTHER) .XX ±.02 [.5mm]				4VLWCSC-2432DM-2		1 2
(ALL) .XXX ±.005 [.13 mm]						
FRACTIONS ±1/32 [.8 mm]						

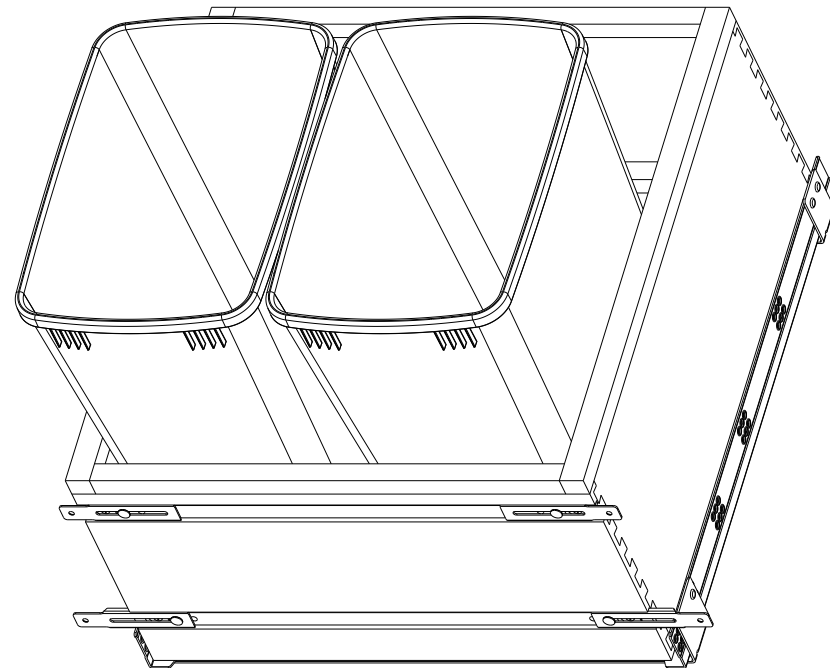

PART DIMENSIONS		
	MIN	MAX
WIDTH	20.50	
DEPTH	21.50	
HEIGHT	19.54	
CONTAINER CAPACITY	32	
CONTAINER UOM	QUART	

MIN CABINET OPENING				
	FACE FRAME	FRAMELESS	INSET FACE FRAME	INSET FRAMELESS
WIDTH	20.50	20.50	20.50	20.50
DEPTH	21.75	21.75	22.50	22.50
HEIGHT	20.00	20.00	20.00	20.00

SLIDE SPECIFICATIONS				
SLIDE MANUFACTURER	BTL			
SLIDE PART NUMBER	BC1A-16-533	RELEASE PART NUMBER		
SLIDE TYPE	UNDERMOUNT	SLIDE EXTENSION	FULL	MAX WEIGHT RATING
SLIDE CLOSING	SOFT/SELF	SLIDE LENGTH	21.00 [533MM]	
SLIDE MOUNTING	BOTTOM	SLIDE FINISH	ZINC	75

CUSTOMER DRAWING

This drawing is the property of Rev-A-Shelf (RAS) and is disclosed in confidence to the extent its subject matter is original to RAS. Any vendor receiving this drawing from RAS shall hold and use this drawing for the sole benefit of RAS and shall not disclose it to, or use or reproduce it for any third party, or perform any act adverse to the interest of RAS with respect to this drawing without the express written permission of RAS. Vendors shall not revise any physical, dimensional or performance characteristic unless authorized by Rev-A-Shelf Engineering.

REV.	DATE	BY	DESCRIPTION OF CHANGE

INCH [MM]	AMERICAN PROJECTION	DRAWN	BY	DATE	REV-A-SHELF, INC.
			KRR	1-2-23	
			SIZE	DOUBLE 32 QT PULL OUT	
			MATERIAL	DRAWING NO.	SCALE
			FINISH	4VLWCSC-2432DM-2	0.150
				4VLWCSC-2432DM-2	PART NO.
				4VLWCSC-2432DM-2	2 OF 2

TOLERANCES
 MAT. DEC.
 (WOOD) .XX ±.03 [.8mm]
 (OTHER) .XX ±.02 [.5mm]
 (ALL) .XXX ±.005 [.13 mm]
 FRACTIONS ±1/32 [.8 mm]

ANGLES ±1/2°