

CUSTOMER DRAWING

This drawing is the property of Rev-A-Shelf (RAS) and is disclosed in confidence to the extent its subject matter is original to RAS. Any vendor receiving this drawing from RAS shall hold and use this drawing for the sole benefit of RAS and shall not disclose it to, or use or reproduce it for any third party, or perform any act adverse to the interest of RAS with respect to this drawing without the express written permission of RAS. Vendors shall not revise any physical, dimensional or performance characteristic unless authorized by Rev-A-Shelf Engineering.

REV.	DATE	BY	DESCRIPTION OF CHANGE

INCH [MM]	AMERICAN PROJECTION 	BY	DATE	REV-A-SHELF, INC.	
		DRAWN	DKK	10-29-18	SIZE B
TOLERANCES		MATERIAL	DRAWING NO.		SCALE
MAT.	DEC.		432-WFBBSC39-3C		0.188
(WOOD)	.XX ±.03 [.8mm]	FINISH	PART NO.		SHEET OF
(OTHER)	.XX ±.02 [.5mm]		432-WFBBSC39-3C		
(ALL)	.XXX ±.005 [.13 mm]				
FRACTIONS	±1/32 [.8 mm]				

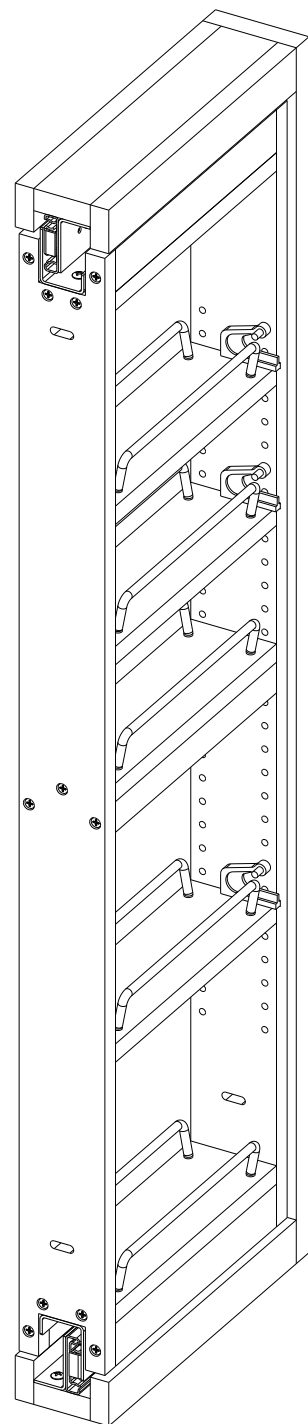

PART DIMENSIONS	
WIDTH	3.00 [76,2]
DEPTH	11.13 [282,6]
HEIGHT	39.00 [990,6]

MCO: N/A (PRODUCT INSTALLS BETWEEN TWO CABINETS)

PRODUCT MAX WEIGHT RATING
BMHA STANDARDS

SLIDE SPECIFICATIONS				
SLIDE TYPE	BALL BEARING	SLIDE EXTENSION	FULL	MAX WEIGHT RATING
SLIDE CLOSING	SOFT CLOSE	SLIDE LENGTH	267MM	
SLIDE MOUNTING	N/A	SLIDE FINISH	ZINC	100 LB

CUSTOMER DRAWING

This drawing is the property of Rev-A-Shelf (RAS) and is disclosed in confidence to the extent its subject matter is original to RAS. Any vendor receiving this drawing from RAS shall hold and use this drawing for the sole benefit of RAS and shall not disclose it to, or use or reproduce it for any third party, or perform any act adverse to the interest of RAS with respect to this drawing without the express written permission of RAS. Vendors shall not revise any physical, dimensional or performance characteristic unless authorized by Rev-A-Shelf Engineering.

REV.	DATE	BY	DESCRIPTION OF CHANGE

INCH [MM]	AMERICAN PROJECTION	DRAWN	BY	DATE	REV-A-SHELF, INC.
			DKK	10-29-18	
TOLERANCES		ANGLES ±1/2°	MATERIAL	DRAWING NO.	SCALE
MAT.	DEC.		FINISH	432-WFBBSC39-3C	0.188
(WOOD) .XX ±.03 [.8mm]	(OTHER) .XX ±.02 [.5mm]		PART NO.	432-WFBBSC39-3C	SHEET OF
(ALL) .XXX ±.005 [.13 mm]	FRACTIONS ±1/32 [.8 mm]				2 OF 2