

NOTE: TO BE SHIPPED DISASSEMBLED

CUSTOMER DRAWING

This drawing is the property of Rev-A-Shelf (RAS) and is disclosed in confidence to the extent its subject matter is original to RAS. Any vendor receiving this drawing from RAS shall hold and use this drawing for the sole benefit of RAS and shall not disclose it to, or use or reproduce it for any third party, or perform any act adverse to the interest of RAS with respect to this drawing without the express written permission of RAS. Vendors shall not revise any physical, dimensional or performance characteristic unless authorized by Rev-A-Shelf Engineering.

REV.	DATE	BY	DESCRIPTION OF CHANGE

INCH [MM]	AMERICAN PROJECTION	DRAWN	BY	DATE	
		JAB	JAB	10/11/23	
TOLERANCES		MATERIAL		DRAWING NO.	
MAT. DEC. (WOOD) .XX ±.03 [.8mm] (OTHER) .XX ±.02 [.5mm] (ALL) .XXX ±.005 [.13 mm] FRACTIONS ±1/32 [.8 mm]		FINISH		4WDIV-30SH-1	
ANGLES ±1/2°		SCALE		0.250	
				PART NO.	
				4WDIV-30SH-1	
				SHEET OF	
				1 2	

NO.	PART NUMBER	DESCRIPTION	QTY.
1	4SDRS-1	SHALLOW DRAWER RAIL SYSTEM DIVIDER	3
2	4SDRS-2	SHALLOW DRAWER RAIL SYSTEM NOTCHED DIVIDER	2
3	4SDRS-3	SHALLOW DRAWER RAIL SYSTEM CROSS DIVIDER	3
4	4SDRS2525-1	25.25" SHALLOW DRAWER RAIL SYSTEM TRACK	2
5	NO 8 X 1"	PHILLIPS FLAT HEAD SCREW	4
6		INSTRUCTION SHEET	1

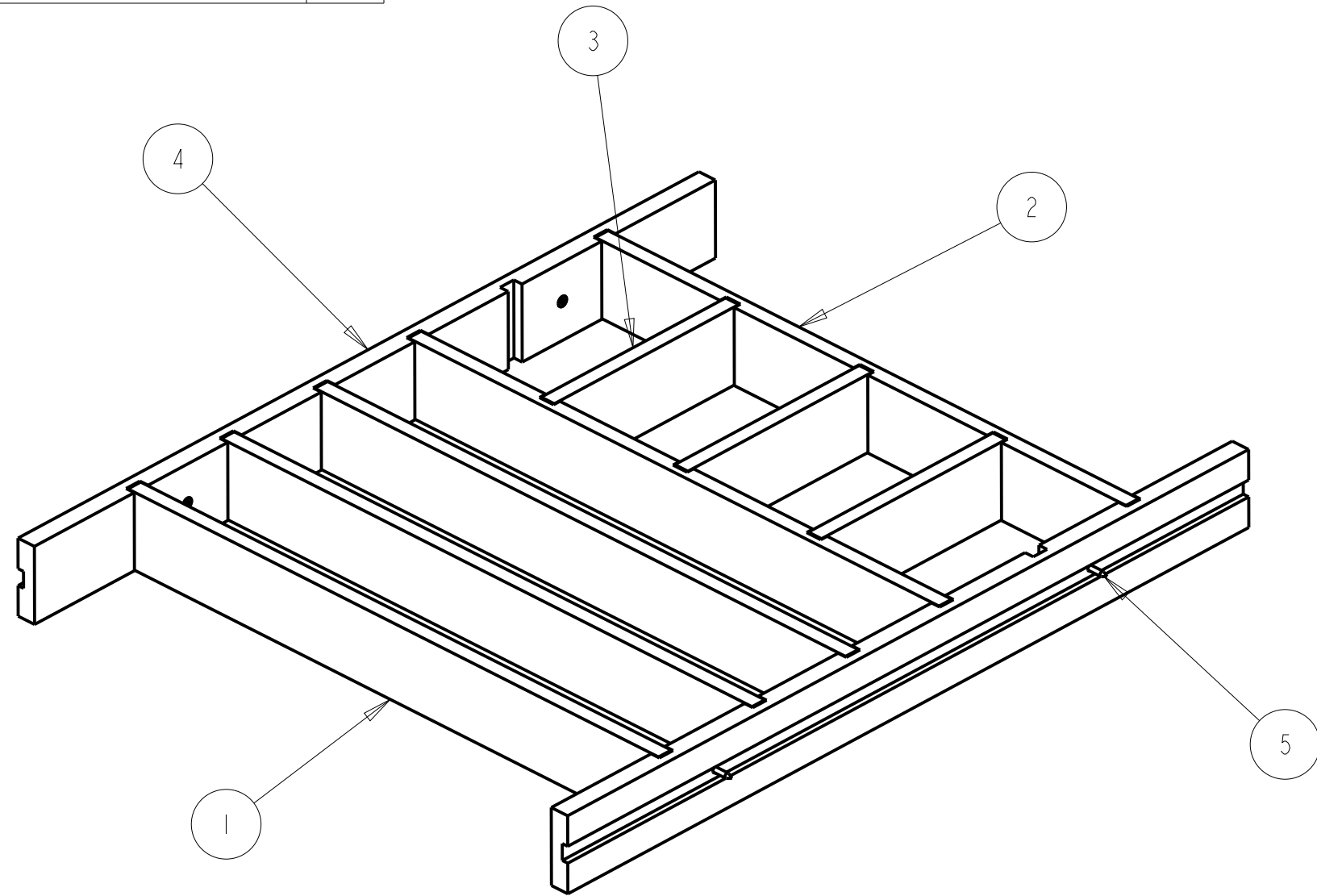

CUSTOMER DRAWING

This drawing is the property of Rev-A-Shelf (RAS) and is disclosed in confidence to the extent its subject matter is original to RAS. Any vendor receiving this drawing from RAS shall hold and use this drawing for the sole benefit of RAS and shall not disclose it to, or use or reproduce it for any third party, or perform any act adverse to the interest of RAS with respect to this drawing without the express written permission of RAS. Vendors shall not revise any physical, dimensional or performance characteristic unless authorized by Rev-A-Shelf Engineering.

REV.	DATE	BY	DESCRIPTION OF CHANGE

INCH [MM]	AMERICAN PROJECTION 	BY	DATE	<b>REV-A-SHELF, inc.</b>
		JAB	10/11/23	
TOLERANCES		MATERIAL	DRAWING NO.	SCALE
MAT. DEC. (WOOD) .XX ±.03 [.8mm] (OTHER) .XX ±.02 [.5mm] (ALL) .XXX ±.005 [.13 mm] FRACTIONS ±1/32 [.8 mm]		FINISH	4WDIV-30SH-1	0.250
ANGLES ±1/2°			PART NO.	SHEET OF
			4WDIV-30SH-1	2 2