

AMC B40A40AC

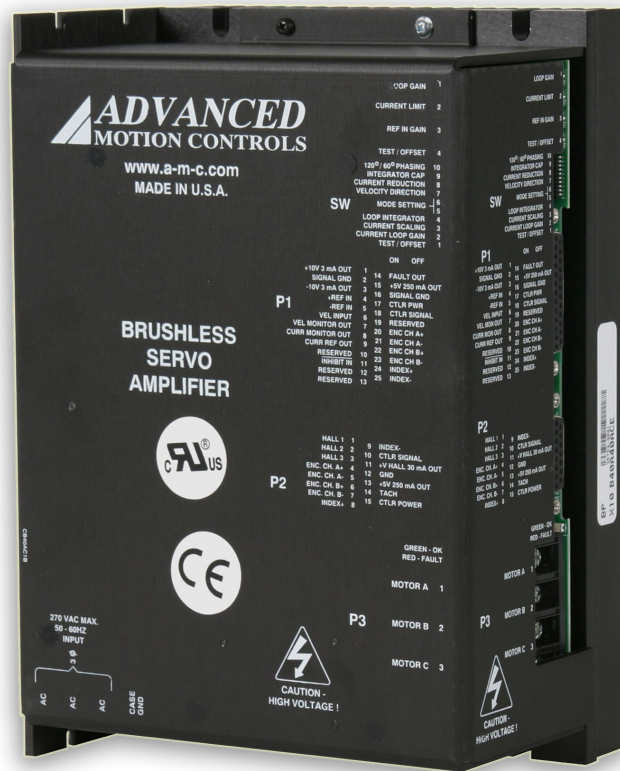

Installation Tech Note

Dallas, Texas

May, 2010

! CAUTION !

Do NOT apply air pressure to release the collet while the servo motor is rotating. The servo motor spindle must be *FULLY STOPPED* before actuating the Collet.

Do NOT overheat the servo motor. Supply the motor cooling water, or compressed air to maintain a temperature below 176 °F (80 °C).

Do NOT start or stop the servo motor instantaneously. Doing so will damage the motor and power amplifier.

Table of Contents

1.0 LIMITED WARRANTY.....	1
2.0 GENERAL OVERVIEW.....	3
3.0 INSTALLATION.....	3
3.1 Safety Instructions.....	3
3.4 MOTOR ACCELERATION/DECELERATION.....	7
4.0 TECHNICAL SPECIFICATIONS.....	8

1.0 LIMITED WARRANTY

Duration:

One year from date of delivery to the original purchaser.

Who gives this warranty (warrantor):

PushCorp, Inc.

Telephone: (972) 840-0208

Corporate Address:

P. O. Box 181915

Dallas, Texas 75218

Shipping Address:

2345 Merrit Drive

Garland, Texas 75041

Who receives this warranty (purchaser):

The original purchaser (other than for purposes of resale) of the *PushCorp, Inc.* product

What products are covered by this warranty:

Any *PushCorp, Inc.* industrial equipment or accessory supplied or manufactured by the Warrantor.

What is covered under this warranty:

Defects in material and/or workmanship which occur within the duration of the warranty period.

What is NOT covered in this warranty:

- A. IMPLIED WARRANTIES, INCLUDING THOSE OF MERCHANT-ABILITY AND FITNESS FOR A PARTICULAR PURPOSE ARE LIMITED TO ONE YEAR FROM THE DATE OF ORIGINAL PURCHASE. Some states do not allow limitations on how long an implied warranty lasts, so the above limitations may not apply to you.
- B. ANY INCIDENTAL, INDIRECT, OR CONSEQUENTIAL LOSS, DAMAGE or EXPENSE THAT MAY RESULT FROM ANY DEFECT, FAILURE, MALFUNCTION OF THE *PUSHCORP, INC.* PRODUCT. Some states do not allow the exclusion or limitation of incidental or consequential damages so the above limitation or exclusion may not apply to you.
- C. Any failure that results from an accident, purchaser's abuse, neglect, unauthorized repair or failure to operate the products in accordance with the instructions provided in the owner's manual(s) supplied with the product.

Responsibilities of the Warrantor under this warranty:

Repair or replace, at Warrantor's option, products or components which have failed within the duration of the warranty period.

PUSHCORP, INC. AMC B40A40AC Amplifier Installation Tech Note

Responsibilities of the purchaser under this warranty:

- A. Deliver or ship the *PushCorp, Inc.* product or component to PushCorp, Inc. Service Center, Garland, TX, USA. Freight and insurance costs, if any, must be borne by the purchaser.
- B. Use reasonable care in the operation and maintenance of the product as described in the owner's manual(s).

When warrantor will perform repair or replacement under this warranty:

Repair or replacement will be scheduled and serviced according to the normal work flow at the service center, and depending on the availability of replacement parts. Purchasers requiring quicker repair may receive such with payment of a *PushCorp, Inc.* predetermined expediting fee.

This Limited Warranty gives you specific legal rights and you may also have other rights which vary from state to state.

2.0 General Overview

The PushCorp, Inc B40A40AC is an analog input DC brushless servo amplifier manufactured by Advanced Motion Controls (AMC). It has been tuned by PushCorp to match the performance characteristics of the STC0605 or SM0605 servo motors. This amplifier along with a servo motor, feedback cable, power cable, amplifier input/output cable and user supplied abrasive media form a complete system for material removal or cutting applications.

CAUTION: The amplifier is pre-configured at PushCorp for a specific motor. There is no reason to adjust any of the potentiometers or DIP switch settings. Tampering with these components without the approval of PushCorp can cause poor system performance and damage to the amplifier or motor.

The B40A40AC is capable of producing 20 amps continuous current with 40 amp peak on a 300VDC motor power bus. The trapezoidal commutation provided by this amplifier is designed to operate with the hall effect velocity feedback of the STC/SM0605 servo motors. It is fully protected against over-voltage, under-voltage, over-current, over-heating, and short-circuits. With the amplifier I/O cable (ASM00885), a simple connection to a cell controller, PLC, robot controller, or discreet control devices can be accomplished. One red/green LED is visible on the front panel to display the operational status.

3.0 Installation

3.1 Safety Instructions

In order to provide a safe and efficient configuration for an B40A40AC Amplifier the following instructions and warnings must be followed.

WARNING: All system components must be connected to a reliable low resistance earth ground. It is impossible to have a safe installation without proper grounding.

WARNING: All covers must be installed and all enclosure doors shut and locked before power is supplied to the amplifier. High voltages are present on the amplifier during operation.

WARNING: Do NOT disconnect any cables or wires from the amplifier or the motor while power is supplied to the amplifier. Electrical arcing can occur which will damage the terminals or contacts.

PUSHCORP, INC. AMC B40A40AC Amplifier Installation Tech Note

WARNING: Do NOT contact the amplifier for a minimum of 10 minutes after power is removed. Capacitors inside the amplifier can store high voltages for a period of time after power is disconnected. Always check the terminals of the amplifier with a voltmeter before disconnection any cables or wires.

CAUTION: Do NOT spin the motor shaft without power supplied to the amplifier. The motor acts as a generator and will charge up the power supply capacitors through the amplifier. Excessive speeds may cause over-voltage breakdown in the output power devices.

3.2 System Wiring

PushCorp can provide an optional ASM00885 amplifier I/O cable that connects to the 'P1' user I/O connector. This cable provides all of the required control and feedback connections for a typical installation. The list of connections and a description are shown below in figure 1. A typical system installation with discrete control components is described in figure 2.

Pin	Name	Color	Description / Notes	I/O
1	+10VDC, 3 mA Max	Red	For customer use	OUTPUT
2	SIGNAL GND	Black	Reference Ground	SGND
3	-10VDC, 3 mA Max	Blue	For customer use	OUTPUT
4	+REF	White/Red	Differential +/- 10VDC Command Input 40K Input Resistance -10VDC = Max RPM Clockwise 0VDC = 0 RPM +10VDC = Max RPM Counterclockwise	INPUT
5	-REF	White/Blue		
7	Velocity Monitor	Grey	Actual Motor Speed, 1V = 1900 RPM	OUTPUT
8	Current Monitor	Brown	Actual motor current SW1-3 = ON: 5.5 Amps / Volt SW1-3 = OFF: 2.75 Amps / Volt	OUTPUT
9	Current Reference	White/Brown	Command signal to current loop. SW1-3 = ON: 7.25 Volts = 40 Amps SW1-3 = OFF: 7.25 Volts = 20 Amps	OUTPUT
11	Fault Inhibit / Enable	Green	Pin pulled low enables amp Inhibit cause Red Fault LED to light.	INPUT
14	Fault LED On	Orange	Output activated on fault	OUTPUT
15	+5V @ 200mA	Violet	For customer use	OUTPUT
17	Temp Thermistor	White/Yellow	Temperature thermistor output. Resistance is inversely proportional to internal motor temperature. If resistance goes below 700 Ohms (Indicates 120° C) then motor should be immediately shut off.	OUTPUT
18	Temp Thermistor	Yellow		

Figure 1. ASM00885 I/O Cable Pin-Out

PUSHCORP, INC. AMC B40A40AC Amplifier Installation Tech Note

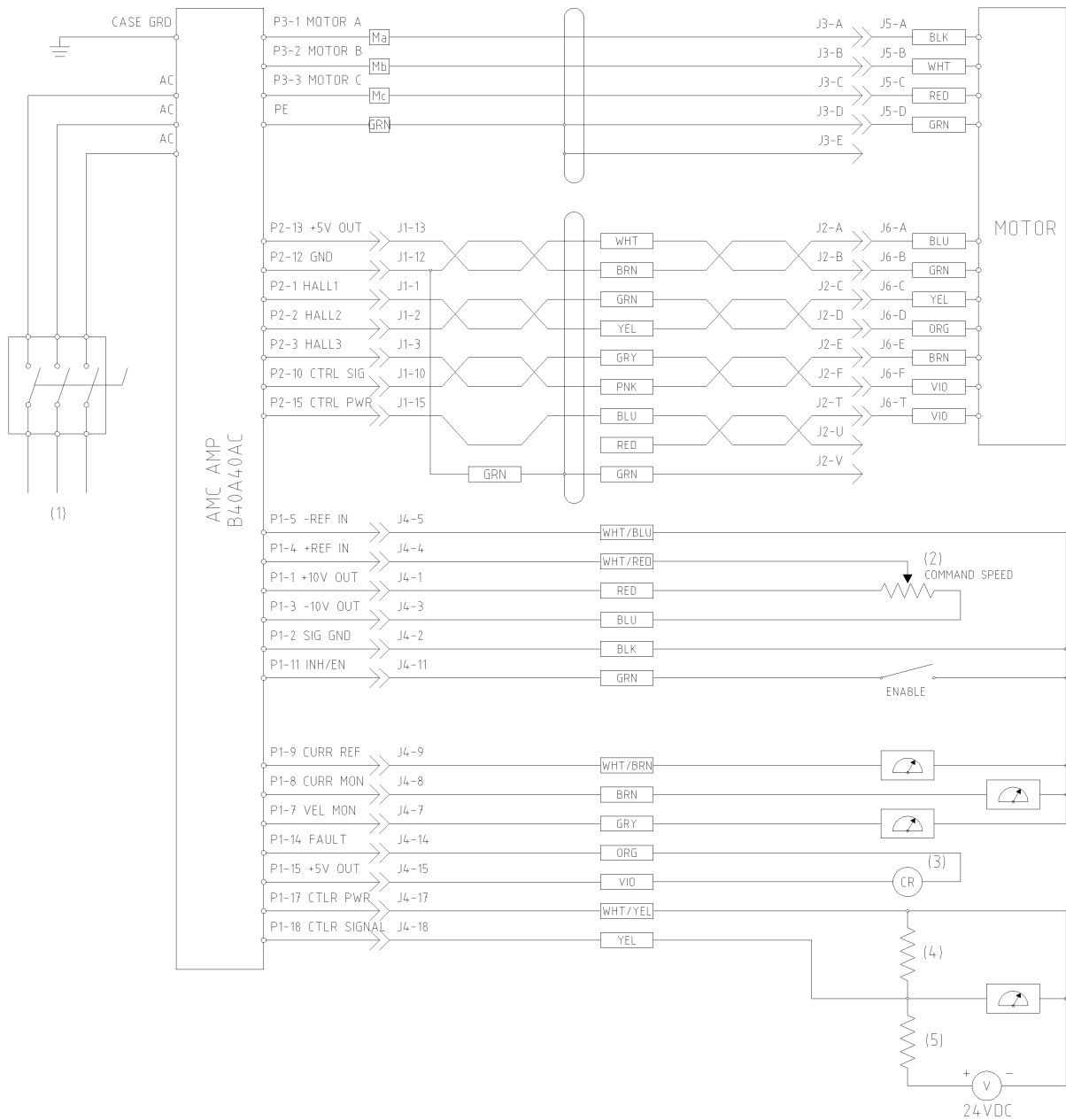

Figure 2. System Wiring Diagram

Notes:

- (1) Supply voltage must be 210-270VAC, 3 Phase, and 50-60 Hz. Power requirement is 4.5 KVA. The amplifier contains a 15A slow blow fuse on each AC line input.
- (2) 20,000 Ohm to 50,000 Ohm Potentiometer
- (3) Crouzet P/N 84130104, 5VDC Input, 24VDC Output Solid State Relay or equivalent
- (4) 2700 Ohm ½ Watt Resistor
- (5) 3900 Ohm ½ Watt Resistor

3.3 Motor Temperature Feedback

The STC/SM0605 is designed to operate below a temperature of 176 °F (80 °C) and within an optimal range of 122-140 °F (50-60 °C). In many situations it is desirable to monitor the internal motor temperature to ensure that the maximum temperature rating is not exceeded, and that the optimal temperature range is maintained. To facilitate this, the STC/SM0605 has a thermistor that is embedded in the motor windings. The thermistor connection is provided on the yellow and white/yellow wires of the ASM00885 amplifier I/O cable. The thermistor temperature signal is a logarithmic function of the output resistance. The graph shown in Figure 3 illustrates the internal motor temperature verses the thermistor output resistance. In the graph, a temperature of 176 °F (80 °C) corresponds to a resistance of 2000 ohms.

CAUTION: If the thermistor indicates a resistance of less than 2000 ohms then the motor should be immediately shut down before thermal damage occurs.

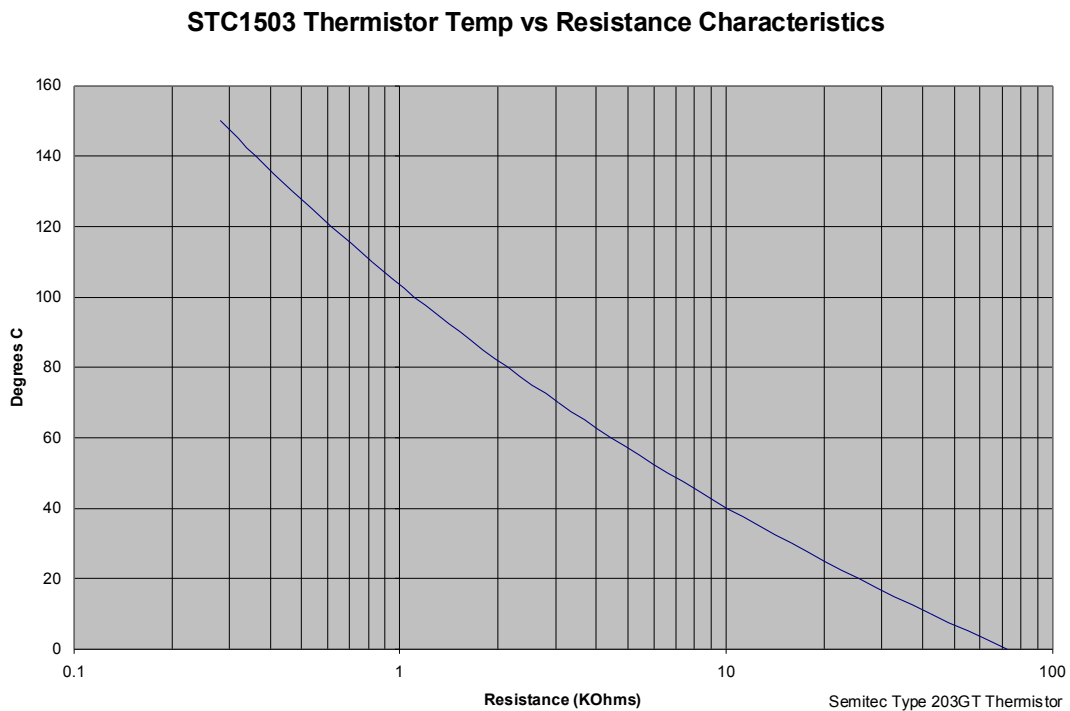

Figure 3. Thermistor Chart

The following equation can be used to calculate the motor temperature based on the measured thermistor resistance:

$$T = \frac{1}{2.656 \times 10^{-3} + 2.317 \times 10^{-4} \ln(R) + 1.752 \times 10^{-7} \ln(R)^3} - 273.15$$

R is resistance in Kohms

$\ln()$ is the natural logarithm function (Base e)

T is temperature in °C

The following circuit shown in figure 4 may be used to provide an approximately linear voltage input to an A/D card to indicate the Internal Motor Temperature:

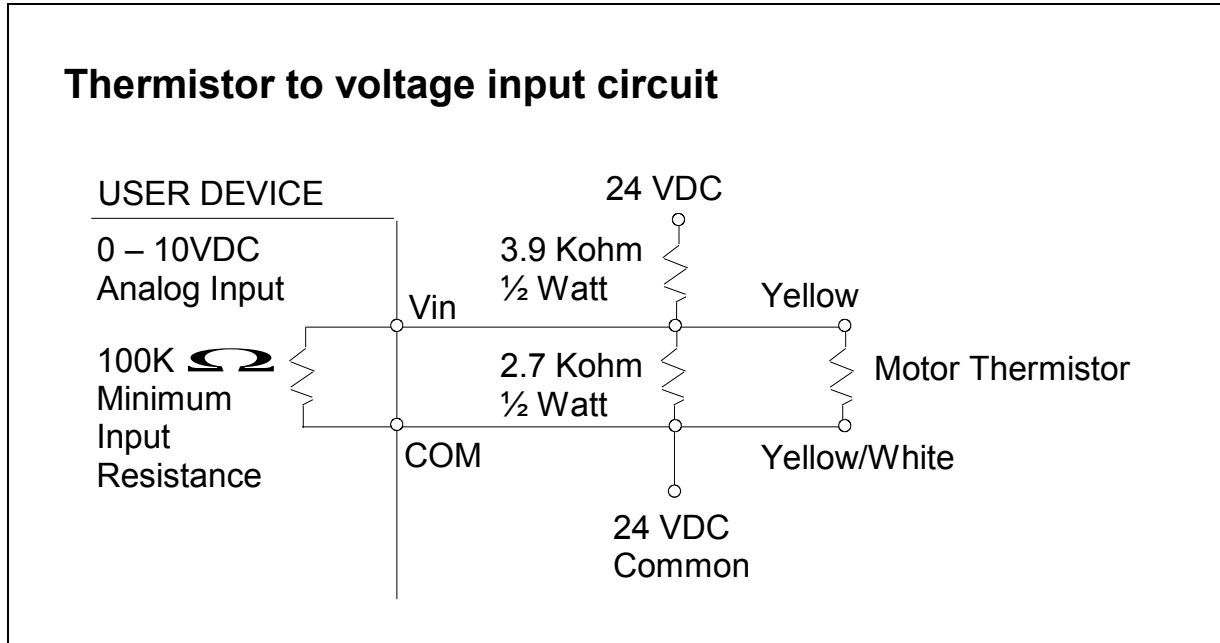

Figure 4. Thermistor Circuit

The voltage input can be converted to approximate internal motor temperature (Deg C) according to the following equation:

$$T = 168.41 - (V_{in} \times 16.02)$$

T is internal motor temperature in °C

V_{in} is input voltage in Volts

3.4 Motor Acceleration/Deceleration

Servo Motors have the ability to start and stop very quickly. As long as the motor does not overheat or the amplifier exceed the allowable current input, the motor will continue to operate. The problem is that the motor and amplifier can experience excessive current spikes with rapid acceleration and deceleration. Media or tooling with a large mass or large diameter (i.e., high moment of inertia) only increases the current surge. The amount of time allowed to reach the desired speed or stop will directly effect the life of the motor. PushCorp recommends a smooth, linear velocity ramp with a *minimum* period of one second be used to accelerate to full speed or to decelerate to zero speed. The minimum one-second-acceleration period must be increased if larger, higher inertia tools are used to prevent servo amplifier faults and avoid long-term damage.

4.0 Technical Specifications

AMPLIFIER SPECIFICATIONS:

Input Power: 220-270VAC, 3 phase, 50-60Hz

Weight: 4.78 lb. (2.16 kg)

Operating Temperature: -13 to 149 °F (-25 to 65 °C)

Thermal Cutoff: 149 °F (65 °C)

For specific dimensions see www.pushcorp.com for detail drawings.

Specifications subject to change without notice.

Fastener Tightening Torque Specs					
Fastener Size	Torque			Minimum Depth	
	in.-lbs.	ft.-lbs.	N·m	in.	mm
M4 x .7	50	4.2	5.6	0.17	4.3
M5 x .8	85	7.1	9.6	0.21	5.3
M6 x 1	140	11.7	15.8	0.25	6.3
M8 x 1.25	348	29.0	39.3	0.33	8.4
M10 x 1.5	600	50.0	67.8	0.41	10.5